



PR Series Positive Rotary Pumps

Models PR, PRE, and PRED

CONTENTS

Thank you for purchasing a Tri-Clover Product!

This manual contains disassembly and assembly instructions, maintenance procedures, troubleshooting, and a complete parts list for all PR Series Pumps designed and manufactured by Tri-Clover, Inc., Kenosha, Wisconsin.

READ THIS MANUAL carefully to learn how to service these pumps. Failure to do so could result in personal injury or equipment damage.

SAFETY

IMPORTANT SAFETY INFORMATION	3
------------------------------------	---

INTRODUCTION

GENERAL INFORMATION	4
---------------------------	---

INSTALLATION

UNPACKING AND INSTALLATION	5
----------------------------------	---

PIPING HINTS	7
--------------------	---

MAINTENANCE

MAINTENANCE AND REPAIR	11
------------------------------	----

ROTOR INSTALLATION	13
--------------------------	----

CLEANING AND INSPECTION	14
-------------------------------	----

TROUBLESHOOTING

TROUBLESHOOTING GUIDELINES	16
----------------------------------	----

PARTS LIST

ORDERING INFORMATION	18
----------------------------	----

PR PUMP	19
---------------	----

PRE & PRED PUMP	21
-----------------------	----

SAFETY

IMPORTANT SAFETY INFORMATION

Safety is very important!

DO NOT attempt to modify any Tri-Clover product. To do so could create unsafe conditions and void all warranties. **DO NOT place any Tri-Clover product in an application where general product service ratings are exceeded.**

The following DANGER, WARNING, AND CAUTION signs and their meanings are used within these instructions.

	 DANGER
	Indicates an imminently hazardous situation which, if not avoided, will result in death or serious injury. The word Danger is used in the most extreme cases.

	 WARNING
	Indicates a potentially hazardous situation which, if not avoided, may result in minor or moderate injury. May also be used to alert against an unsafe operating or maintenance practice.

	 CAUTION
	Indicates a potentially hazardous situation which, if not avoided, could result in death or serious injury.

INTRODUCTION

GENERAL INFORMATION

GENERAL

This manual contains installation, operation, cleaning, and repair instructions, with parts list, for PR, PRE, PRED pumps manufactured by Tri-Clover, Inc. of Kenosha, Wisconsin. It also provides a troubleshooting chart to aid in determining pump malfunctions.

	<p style="text-align: center;">⚠ WARNING</p> <p>Before servicing pump, disconnect electrical power source.</p>
---	---

DESCRIPTION

The PR, PRE and PRED Series pump units are generally mounted on base plates which accommodate the pump units and the drive motors.

The pump units are comprised of two sections, the pump frame section and the fluid head section.

The drive shaft and pump shaft with their respective o-rings, bearings, seal and retaining rings are located in the inner pump frame section.

The timing gears are keyed to the shafts. Axial movement of the gears is kept to a minimum by shaft shoulders and retaining rings.

Lip seals on the shafts and o-ring seals on the frame bores, prevent leakage of timing gear lubricating oil into the pump bearing grease chamber.

Sealing of the fluid head along the shafts is accomplished by rotary seals, consisting of stationary stainless steel seal rings with carbon inserts, stainless steel wear rings which are broached to fit the shaft splines, and o-rings which seal off any pumpage.

An optional cover containing a pressure relief valve provides a positive means of protecting the processing equipment and piping from excessive head pressures.

Rotors are available in two materials - rubber and metal. Rubber and metal rotors are available in double and four lobe design.

The drive motors, used in conjunction with the PR, PRE and PRED Series Pumps are not covered in this manual. Refer to the individual motor or drive manufacturer for service data.

INSTALLATION

UNPACKING AND INSTALLATION

UNPACKING EQUIPMENT

Check the contents and all wrapping when unpacking your equipment. Inspect all parts for damage that may have occurred during shipping.

Note: If the plastic pump port covers have been broken or disturbed in shipment, dismantle fluid head to make sure it is free of all foreign materials before placing pump in service.

INITIAL LUBRICATION

The pump unit is lubricated at the factory prior to shipping and will require no additional lubrication until after the pump is put into service. When you receive the pump:

1. Remove the shipping plug from the top position in the gear cover and install the vented plug shipped with the pump.
2. Check the oil level in the gear case. Oil should be even with the plug opening marked with the "oil level" decal. If oil is required, refer to the *Maintenance and Repair* section on page 12 of this manual for details.

LOCATION

The pump unit should be located as near as possible to the liquid source and in a position where the suction piping can be short and direct with a minimum number of elbows and fittings. It should also be readily accessible for inspection, cleaning and lubrication.

FLEXIBLE COUPLINGS

The purpose of a flexible coupling is to compensate for temperature changes, and allow end movement of the pump and motor shafts without interference with each other while transmitting power from the motor to the pump. A flexible coupling should not be used to compensate for shaft misalignment.

When properly aligned, the flexible coupling should appear as shown in the adjoining drawing. See Figure 1.

The faces of the coupling halves should be far enough apart so that they do not touch each other when the motor shaft is moved toward the pump.

The tools required for checking flexible coupling alignment are a straightedge and taper gauge or set of feeler gauges. See Figures 2 and 3.

Figure One

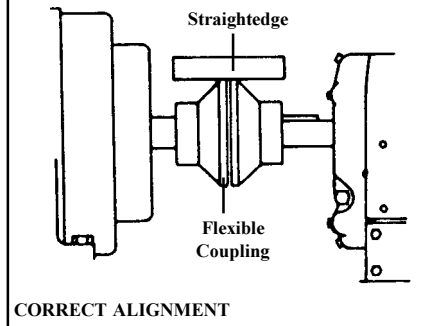

Figure Two

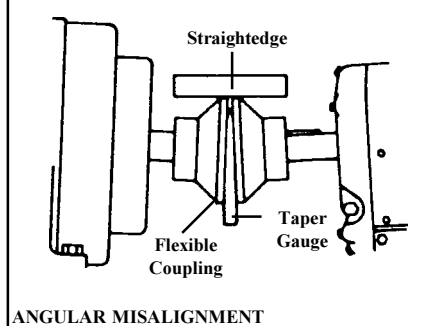
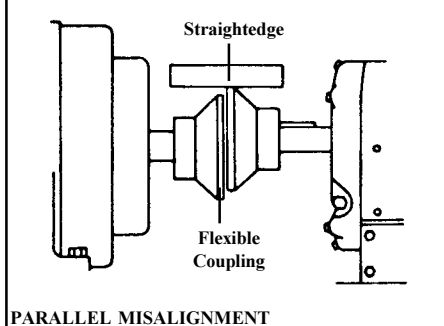

Figure Three



INSTALLATION

FLEXIBLE COUPLING ALIGNMENT

There are two types of misalignment encountered with flexible couplings, angular misalignment and parallel misalignment. To check for angular misalignment, insert a taper gauge or feeler gauge at four places located 90° apart around the coupling as shown. Coupling halves will be aligned when the measurements are the same at all check points.

To check parallel misalignment, place a straightedge across the coupling half rims at the top, bottom and both sides, making sure that the straightedge is parallel to the motor and pump shafts. The coupling will be properly aligned when the straightedge rests evenly on the coupling rims at all check points.

Correct alignment is obtained by use of shims under the motor mounting feet. Remember that adjustments made in one direction may affect alignment in another direction. Therefore, several checks of both angular and parallel alignment should be made.

SEAL FLUSHING - PRED PUMPS

All PRED Series Pumps have double-static o-ring product seals which must have flush liquid applied to them.

Install seal flush as shown below. Use pressurized flush with products that tend to build up between seal faces; latex, PVA, etc. Pressure in seal chamber should exceed pump discharge pressure by at least 10 PSI.

Note: Your Positive Rotary Pump is designed for either clockwise or counterclockwise rotation. It should be noted that product flow will be in the same direction as the drive shaft rotation.

Connect the flexible coupling, start the pump and operate it until temperatures are stabilized. The unit should then be shut down and the alignment immediately rechecked.

Note: If corrections in alignment are necessary at this time, be sure to check in all directions after making adjustments.

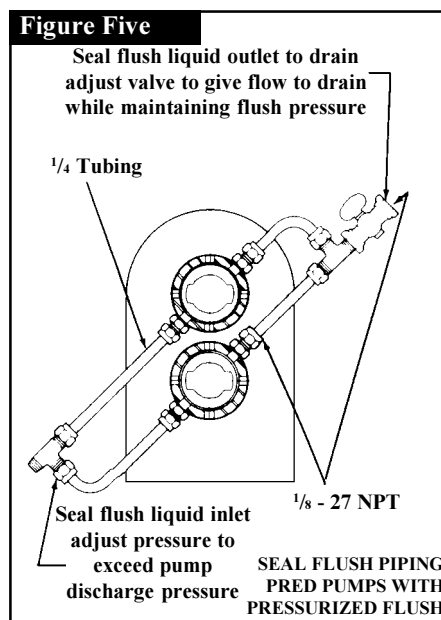
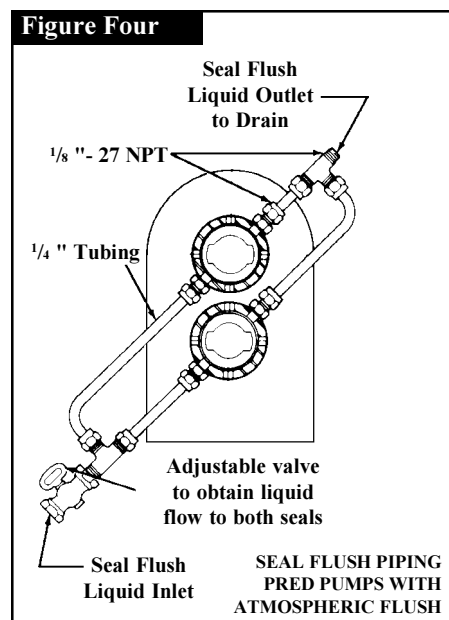

Recommended Seal Flush Flow Rate is approximately 3 gallons per hour. For elevated temperature applications, flow rate must be sufficient to maintain seal temperature of 175°F or less.

INSTALLATION

PIPING HINTS

GENERAL

This section provides some do's and don'ts of piping which will aid in obtaining the maximum efficiency and service from your pump.

- Piping should be independently supported at both the suction inlet and discharge outlet.
- Care should be taken that piping is properly aligned and does not put any strain on the pump casing.
- The piping should have as few bends as possible.

SUCTION PIPING

- The suction piping should be short and follow a direct route with a minimum number of elbows and fittings.
- Elbows should not be used at the suction inlet as friction would be greatly increased, resulting in head loss.
- Excessive friction losses in the suction line could result in pump cavitation, causing poor performance, noise, vibration, damage to equipment, and possible damage to product.
- Whenever practical, the diameter of the piping at the suction inlet should be increased in size.
- An eccentric tapered reducer should be used in lieu of a straight concentric tapered reducer to prevent air pockets from forming and impairing pump efficiency. In turn, the eccentric reducer may be placed at the inlet of the pump and should be positioned so the straight side is up.
- Although positive displacement pumps are self-priming under moderate suction lift conditions, a flooded suction is always preferable.

DISCHARGE PIPING

- The discharge piping should be short and direct with a minimum number of elbows and fittings. It is advisable to increase the pipe diameter at the discharge outlet to minimize head loss.

PRESSURE RELIEF COVER ADJUSTMENT

Tri-Clover's relief cover is designed for added protection of the pump and other processing equipment. The product flow will stop or is reduced when the head pressure on the discharge side of the pump exceeds the pressure rating controlling the piston in the relief cover.

The relief cover is designed for use with either manual or pneumatic controls.

To adjust, install a line pressure gauge in the discharge line of the pump as close as possible to the discharge port. Determine a maximum line pressure rating that is higher than the operating pressure and adjust as follows:

INSTALLATION

Manual:

1. Loosen jam nut (09B-6).
2. Turn the adjusting screw (09-5A) (clockwise to increase pressure - counterclockwise to decrease pressure) until the reading on the pump discharge line pressure gauge is the same as the predetermined maximum line rating - then retighten jam nut (09B-6).

Pneumatic:*

When back pressure is regulated by pneumatic control, the spring inside the relief cover must be removed prior to the operation. To remove spring it is necessary to remove relief cover parts in the following sequence:

1. Jam nut (09B-6).
2. Clamp (13MON-X-S).
3. Cap nut (09B-3A).
4. Retaining ring (09B-13).

* For PR300 replace cap nut (09B-3A), adjusting screw (09B-13) and jam nut (09B-6) with R3-1-09D-3 cap.

Reassemble relief cover omitting retaining ring (09B-13) and spring (09B-4) and follow instructions below for pneumatic operation:

1. Loosen jam nut (09B-6).
2. Turn the adjusting screw (09B-5A) counterclockwise until o-ring (09B-14) is slightly compressed, then retighten jam nut (09B-6).
3. Adjust pressure control valve at the source of supply (air or CO₂) until the reading of the discharge line pressure gauge is the same as the predetermined maximum line pressure rating.

MAINTENANCE

CLEANING



WARNING

Before servicing the pump, disconnect the electrical power source, carefully relieve all pressure, and drain all fluids from the pump and connected piping.

DISASSEMBLY OF PUMP FLUID HEAD

It is necessary to disassemble parts of your pump for cleaning and sanitizing. Disassemble as described below after disconnecting the suction and discharge piping. If so equipped, also disconnect the relief cover air line.

Note: For added protection when disassembling pump fluid head, place all parts on rubber mat or wooden platform. Extreme care must be exercised during assembly and disassembly of the fluid head - especially in handling of the rotary seal parts and rotors.

1. Remove casing nuts and slide the casing cover off the casing studs. Carefully remove the o-ring from the inside of the cover.
2. Remove the rotors from the drive and pump shafts.
3. Slide the casing off the studs.
4. Carefully remove the casing o-rings from the rear of the casing.
5. Slide the seal rings off the shaft.
6. Remove the wear rings. If necessary use Puller No. R80-200. Do not pry wear rings off with a screwdriver or similar tool as the flanges may be damaged. Carefully remove shaft o-rings. On PRED models, with double seal assemblies, remove rear seal rings and o-rings.

Seals: Inspect the carbon face of the seal ring and the wear ring seal surface for nicks, scratches or excessive wear. Inspect all o-rings for cuts, abrasions or wear. Replace any damaged or worn parts.

Rotors: Inspect rubber rotor for cuts, cracks or other damage to the rubber composition. Inspect metal rotor carbons for cracks or wear and replace if damaged. Check fit of metal or rubber rotors on shafts and replace if excessively loose.

MAINTENANCE

REASSEMBLY OF FLUID HEAD

Note: Sequence of disassembly and assembly is the same for models PR, PRE and PRED except where noted.

To reassemble the fluid head:

1. Lubricate shaft o-rings with silicone grease (Tri-Clover L1011B) and insert o-rings into grooves on shafts.
2. On PRED models, insert rear seal o-rings into alignment locating ring.
3. Slide rear seal rings into place in alignment locating ring.
4. For all models slide wear rings into place onto the shafts.
5. Slide seal rings into place. DO NOT LUBRICATE SEAL FACES EXCEPT WITH CLEAR WATER. USE OF SANITARY LUBRICANTS MAY DAMAGE CARBON. TANGS ON THE SEAL RINGS MUST BE ALIGNED WITH SLOTS IN CASING. SEAL AND PUMP CASING CAN BECOME PERMANENTLY DAMAGED IF TANGS ARE NOT PROPERLY ALIGNED.
6. Insert casing o-rings into place on back of casing.
7. Slide casing securely into place.
8. Slide rotors in place over splined shafts.
9. Insert cover o-ring.
10. Place front cover in position on studs.
11. Replace and tighten the casing nuts.
12. Reconnect the suction and discharge piping.

MAINTENANCE

MAINTENANCE AND REPAIR

Maintenance of the PR, PRE and PRED pumps includes frequent lubrication of the shaft bearings, checking the oil level in the timing gear compartment, changing of oil at regular intervals, and inspection of pump components.

LUBRICATION OF OUTBOARD AND INBOARD BALL BEARINGS

The bearings should be greased after every 100 operating hours, using a high quality grease such as Mobile Temp #1. Old grease in the grease chamber should be periodically removed by removing the cleanout hole cover and scraping out excess grease. Mixing of different brands of grease should be avoided, to prevent possible chemical reactions between the brands, which could damage the bearings. Greases containing vegetable or animal bases should not be used because they can develop harmful acids. Also avoid using greases containing graphite, rosin, talc and other impurities.

Note: Be sure the lubrication fittings are wiped clean before greasing, to prevent dirt from being forced into the bearings during greasing.

If your pump has been operated under extremely dusty or wet conditions for several months, or has been idle for a long period of time, the bearings should be cleaned thoroughly with white gasoline or kerosene and new grease applied. Refer to the applicable paragraph for disassembly, cleaning and inspection procedures.

LUBRICATION OF TIMING GEARS

The timing gears are lubricated with SAE 20 oil. At regular intervals check the oil level by removing the oil level plug. Oil should be even with the bottom of the plug opening.

Every 200 operating hours, remove drain plug and drain the timing gear chamber. Add new oil until proper level is reached.

DISASSEMBLY

It is recommended that periodic inspection of all parts be made to prevent malfunction caused by worn or broken parts. To accomplish this inspection, it is necessary to completely disassemble the pump. Sequence of disassembly is the same for models PR, PRE and PRED.

Disassembly of the Casing and Rotor

1. Disconnect the suction and discharge piping. Also disconnect the water line to the shaft seal flush assembly, if pump is so equipped.
2. Remove the four bolts securing the pump to the base plate.

Note: If the pump is removed from the base plate, be sure that any shims used to level the pump are fastened together by some suitable means, tagged and reinstalled at their original location at time of reassembly.

Disconnect the flexible coupling half from the pump shaft.

3. Remove the coupling key from the shaft. Remove casing nuts and slide casing cover from studs. Carefully remove casing cover o-ring.
4. Disassemble the relief cover, if used, by removing the jam nut, clamp, cap nut and gasket. Remove the retaining ring and slide the adjusting screw spring and thrust washer from the piston. Carefully remove the o-ring from the adjusting screw.

MAINTENANCE

5. Remove the piston from the relief cover and carefully remove the o-rings and PTFE sleeves from the piston.
6. Slide off the drive shaft and pump shaft rotors.
7. Remove the casing and carefully remove the casing o-rings.
8. Slide the seal rings of the shafts and carefully remove wear rings. If necessary use Puller No. R80-200. Do not pry off with a screwdriver or similar tool which may bend flange area of wear ring.

Note: Do not use a screwdriver or a pointed tool to remove seals and o-rings. The seals and o-rings are precision parts and are easily damaged.

9. Remove the shaft o-ring by placing the thumb of one hand and forefinger across the diameter of the o-ring and pressing it with a circular motion so that the o-ring projects from the groove. With the forefinger of the other hand work the o-ring from the shaft groove.
10. Remove the vented plug and the oil level plug. Drain the oil from the timing gear case by removing the drain plug. Remove the gear cover cap screws and the gear cover.
11. Carefully remove the gear cover gasket.
12. Press out the gear cover seal if replacement is necessary.
13. Remove the timing gear retaining ring (Part No. 98) from each shaft. On models PR300, PRE300 and PRED300, bend back the tab on lockwasher (Part No. 69), and remove locknut (Part No. 22) and lockwasher.
14. Use suitable pullers and remove the timing gears.
15. Remove the woodruff keys from shafts.
16. Remove the outboard bearing cover retaining rings.
17. Press each shaft and bearing assembly through the housing from the rotor end. If a press is not available, a soft hammer or a block of wood can be used to drive the shaft from the housing.
18. Remove the outboard bearing cover and o-ring. Push out the bearing cover seal if replacement is required.
19. If it is necessary to remove the alignment locating rings, use a long punch to tap them from the inside of the frame. Note the original positions of these rings. The grooves in the rings must be carefully aligned with grease fittings at reassembly. Press the seal from the alignment locating ring if replacement is necessary.

No further disassembly is recommended unless inspection shows that replacement of bearings or shafts is required. If bearings are to be replaced, remove the bearing retaining ring. Using a bearing puller or an arbor press, remove the damaged bearing from the shaft.

MAINTENANCE

ROTOR INSTALLATION

Your Tri-Clover pump will operate only if the rotors are correctly installed. Therefore carefully follow the installation procedure listed below.

TWO LOBE ROTORS

1. Install 2D rotor onto top shaft.

Note: It doesn't matter whether top shaft is pump shaft or drive shaft.

2. After installing 2D rotor, rotate shaft if necessary to obtain spline relationship as shown in Figure 6.
3. Install 2P rotor on lower shaft. 2P rotor must be installed as shown in Figure 6. Rotors must form a "T" shape when properly installed with the tip of one rotor opposite the concave hub areas of the mating rotor.

Note: Pump cannot be operated unless the above procedure is followed. If rotors are not installed as shown, the pump will jam when started resulting in damage to the rotor or shaft.

SINGLE LOBE ROTORS

1. Install 1D rotor onto top shaft.

Note: It doesn't matter whether top shaft is pump shaft or drive shaft.

2. After installing 1D rotor, rotate shaft if necessary to obtain spline relationship as shown in Figure 7.
3. Install 1P rotor on lower shaft. 1P rotor must be installed as shown in Figure 7. Large lobe of one rotor must be next to small diameter or hub of mating rotor.

Note: Pump cannot be operated unless the above procedure is followed. If rotors are not installed as shown, the pump will jam when started resulting in damage to the rotor or shaft.

Figure Six

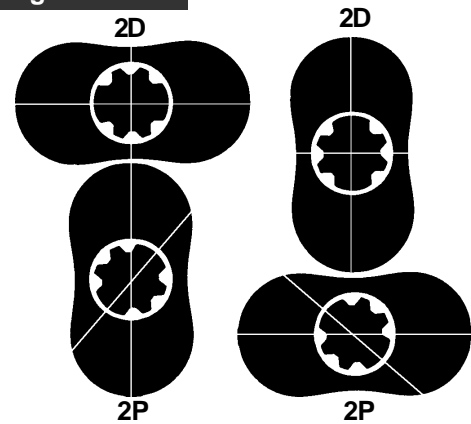

Part 2D - Center line of wide spline teeth is on center line of rotor lobes.

Part 2P - Center line of wide spline teeth is at a 45° angle with center line of rotor lobes.

Figure Six

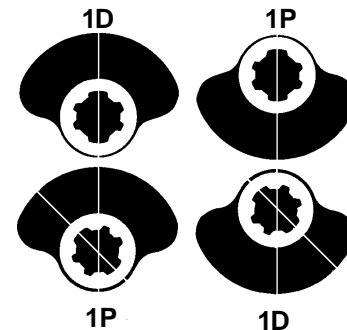

Part 1D - Center line of wide spline teeth is on center line of rotor lobes.

Part 1P - Center line of wide spline teeth is at a 45° angle with center line of rotor lobes.

MAINTENANCE

CLEANING AND INSPECTION

1. Remove cleanout hole cover, and remove any accumulation of grease from inside of the grease chamber.
2. Inspect the pump frame, gear cover and casing for cracks or other damage that could impair function of the pump.
3. Clean the outside of the frame, shaft, timing gears and bearing covers with a clean rag soaked in white gasoline or kerosene, and flush all surfaces.
4. Flush the inside of the pump frame with white gasoline or kerosene to remove any harmful material. Dry with compressed air or allow solvent to evaporate.

Note: Clean rotor end of the shaft thoroughly after reassembly to remove any solvent that could contaminate the process fluid.

5. Inspect the shafts carefully for nicks or scratches. Remove small nicks or scratches with a fine file or emery cloth.
6. Examine the bearing covers and rotors for cracks or other signs of excessive wear.
7. Examine the key slots in shafts and gears and woodruff keys for signs of wear. Keys must fit tightly in key slots.

SEAL INSPECTION - SEAL RING

1. Inspect the carbon face of the seal ring and seal ring chamber for nicks and scratches on the sealing surfaces.
2. Carefully inspect the wear ring for excessive wear.
3. Examine the bearing cover seal, alignment ring seals, and the gear cover seal for cracks, nicks and excessive wear.
4. Inspect all o-rings for cuts, abrasions or other wear that can cause leakage.
5. Carefully examine the gear cover gasket and cleanout cover gasket for nicks, cuts, scratches or excessive wear.

Parts showing excessive wear should be replaced.

REASSEMBLY

If it is necessary to replace the bearing cover seals or alignment ring seals, the new seal must be installed with the spring loaded seal lip facing away from the bearings. The spring loaded seal lip on the gear cover seal must face the gears.

If it is necessary to replace the bearings:

1. Press the bearings onto the shaft and install the bearing retainer ring (Part No. 102).
2. Install the inboard shaft retainer ring (Part No. 177) in the pump frame.
3. Place the outboard bearing cover seal, outboard bearing cover and outboard bearing cover o-ring on the shaft.
4. Stand the pump on the eight studs and start the shaft through the pump frame.
5. Press the shaft until the bearings are firmly seated*. Install the outboard bearing cover retainer rings (Part No. 177). Align slots with grease fittings. Lubricate the bearings.

* These bearings are an easy fit, and will not require much force.

MAINTENANCE

6. Install the woodruff keys in the shaft key slots and press the timing gears onto the shafts.
7. Carefully align the timing marks on the gears as shown in Figure Eight.
8. Install the timing gear retaining rings (Part No. 98).
9. On Model PR300, PRE300 and PRED300 pumps, assemble lockwasher (Part No. 69) and locknut (Part No. 22) on the shafts.
10. Tighten locknut firmly and lock in place by bending a tab into a slot on the locknut.

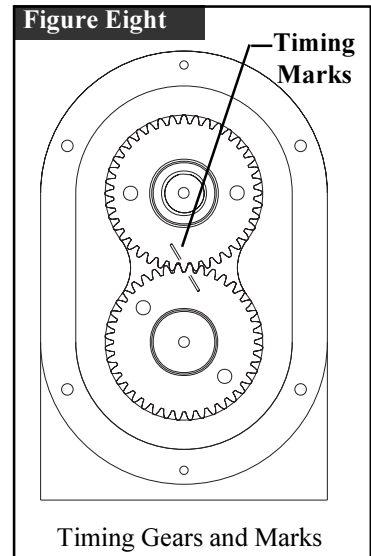

11. Insert seal in gear cover, carefully fit the cover gasket to the cover and secure the gear cover to the pump frame with the cap screws.
12. Install the drain plug, fill the oil reservoir to the proper oil level and install the vent plug and the oil level plug.
13. Assemble the cleanout cover to the pump frame.
14. Install the alignment locating rings. Be sure to align the slots in these rings with the grease fittings.
15. Install the shaft o-rings and the wear rings.
16. Slide the seal rings onto the shafts and carefully align the tangs of the seal rings with the slots in the casing.
17. Assemble the casing o-rings and casing and slide into place.

Note: The seal rings and pump casing can become permanently damaged if tangs are not properly aligned. Do not lubricate seal faces. Carbon will be damaged if lubricated.

18. Install the rotors and place casing cover o-ring in casing cover groove. Secure the cover to the casing with the casing nuts.
19. Assemble relief cover in the reverse order of disassembly.
20. Rotate the drive shaft. If the pump rotates smoothly and is not leaking oil, mount it on the base, and connect the flexible coupling to the pump shaft.
21. Align the coupling according to instructions given under the *Installation* section of this manual.

IMPORTANT: Be sure the bearings have been lubricated and gear oil added before placing the pump back in service.

22. Connect the suction and discharge piping, and the water line to the seal flush assembly.
23. Reset pressure relief valve as described in relief cover adjustment.

TROUBLESHOOTING

TROUBLESHOOTING GUIDELINES

Tri-Clover pumps are relatively maintenance free with the exception of sanitizing and lubrication. Like any piece of machinery, however, occasional problems can arise. The troubleshooting chart provides a means of determining and correcting most of your pump problems. The motor manufacturer should be contacted for specific repair instructions on the motor.

Note: The troubleshooting chart has been prepared on the basis that the pump as installed has been properly suited to its application. Should problems arise where the remedies listed in the troubleshooting chart do not cure the situation, pump cavitation may be the problem. Symptoms of pump cavitation, such as noisy operation, insufficient discharge and vibration, can result when a pump is not properly applied. If these conditions are present, check the system and reevaluate the application. If assistance is required, contact Tri-Clover.

PROBLEM	PROBABLE CAUSE	REMEDY
1. No discharge	<ul style="list-style-type: none"> a. Pump speed too slow. b. Wrong direction or rotation. c. Closed valve. d. Obstruction in discharge piping. 	<ul style="list-style-type: none"> a. Correct wrong or poor electrical connections. b. Reverse a three-phase motor by switching any two of three power leads at the motor or controller. Reverse a single phase motor according to motor nameplate instructions. c. Open valve. d. Clear obstruction.
2. Insufficient discharge	<ul style="list-style-type: none"> a. Pump speed too slow. b. Valve partially closed. c. Obstruction in discharge piping. d. Rotor damaged. e. Air leak in suction line. f. Cavitation 	<ul style="list-style-type: none"> a. See 1.a. above. b. See 1.c. above. c. See 1.d. above. d. Replace rotors. e. Check suction line joints. f. See note at beginning of <i>Troubleshooting</i> section.
3. Excessive power consumption	<ul style="list-style-type: none"> a. Motor speed too high. b. Rotors are binding. c. Motor shaft is bent or worn. d. Power frame shaft is bent or worn. e. Power frame bearings are worn. f. Excessive misalignment between pump and driver. 	<ul style="list-style-type: none"> a. Internal motor wiring is incorrect replace motor; check line voltage. b. Relieve strain on casing; replace defective rotors. c. Replace shaft. d. Replace shaft. e. Replace bearings. f. Align pump and driver.

TROUBLESHOOTING

PROBLEM	PROBABLE CAUSE	REMEDY
4. Pump is noisy	<ul style="list-style-type: none"> a. Magnetic hum. b. Motor bearings are worn. c. Foreign matter is rotating with impeller. d. Rotors are binding. e. Motor shaft is bent or worn. f. Power frame shaft is bent or worn. g. Power frame bearings are worn. h. Excessive misalignment between pump and driver. i. Cavitation. 	<ul style="list-style-type: none"> a. Consult motor manufacturer. b. Replace bearings. c. Remove casing and remove foreign matter. d. See 3.b. on the previous page. e. See 3.c. on the previous page. f. See 3.d. on the previous page. g. See 3.e. on the previous page. h. See 3.f. on the previous page. i. See note at beginning of <i>Troubleshooting</i> section.
5. Excessive vibration	<ul style="list-style-type: none"> a. Pump is not leveled properly. b. Excessive misalignment between pump and driver. c. Rotors are damaged. d. Piping is not supported. e. Power frame shaft is bent or worn. f. Cavitation. 	<ul style="list-style-type: none"> a. Level pump. b. See 3.f. on the previous page. c. Replace rotors. d. Support discharge and suction piping. e. See 3.d. on the previous page. f. See note at beginning of <i>Troubleshooting</i> section.
6. Pump leaks	<ul style="list-style-type: none"> a. Casing cover loose. b. Damaged inlet or outlet fittings. c. Casing cover o-ring defective. d. Casing o-rings defective. e. Mechanical seal worn or defective. 	<ul style="list-style-type: none"> a. Tighten casing nuts. b. Replace casing. c. Replace o-ring. d. Replace o-rings. e. Replace seal.

PARTS LIST

ORDERING INFORMATION

ORDERING REPAIR PARTS

All orders for repair parts must contain the following data.

1. Complete model number (located on nameplate).
2. Pump serial number (located on nameplate).
3. Description and part number from parts list.

The exploded views and accompanying parts lists in this section facilitate ordering repair parts from the factory. All parts of the pumps are exploded and keyed to the parts list.

ORDERING IMPELLERS

When ordering impellers, the base number designates the impeller size. To order a pump impeller, specify the following:

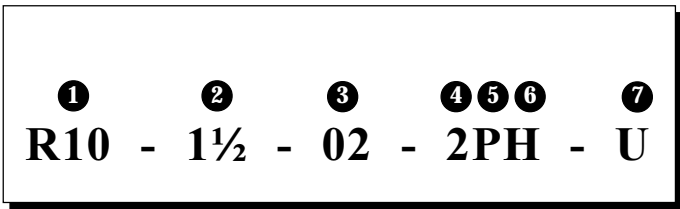
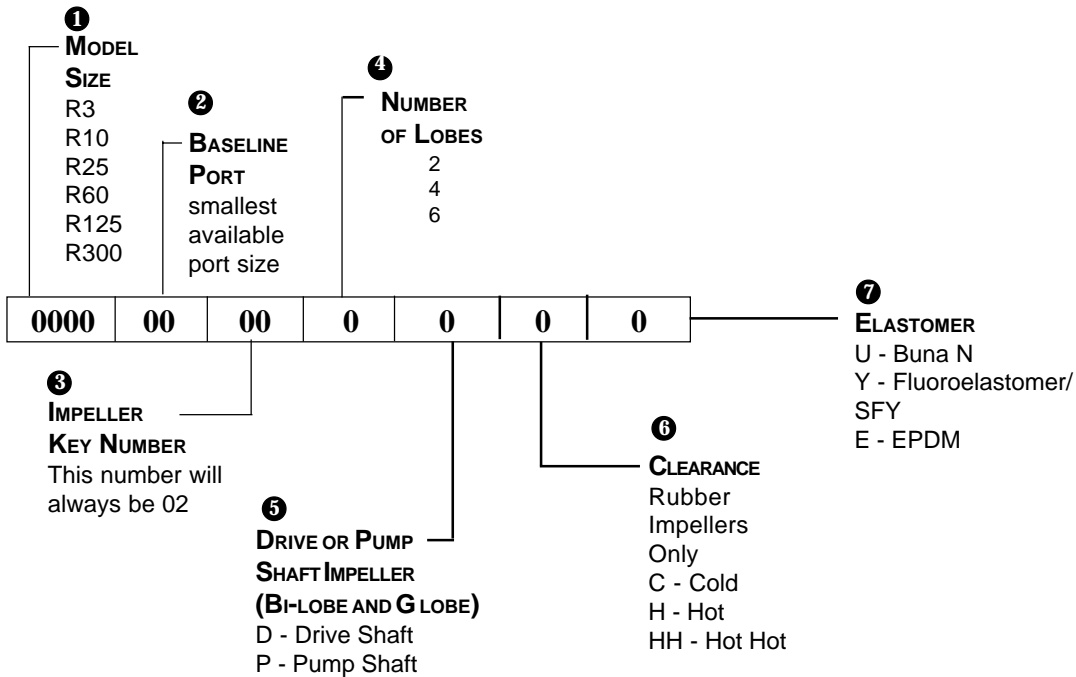

PR PUMP

PARTS LIST

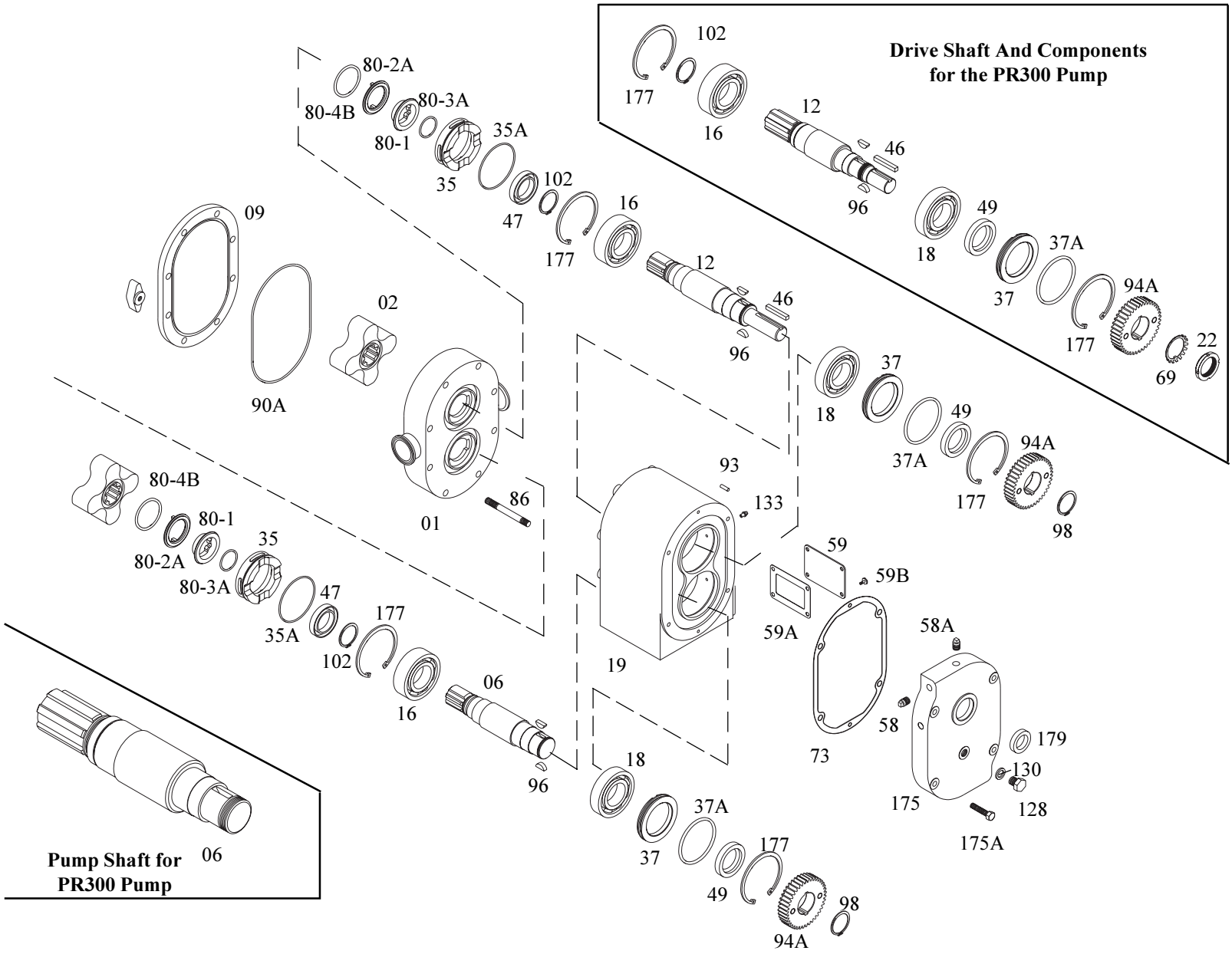

PR Pump

Key	Description	Model 3	Model 10	Model 25	Model 60	Model 12
01	Casing, Threaded Ports 1" x 1"	R3-1-01-316	Not available	Not available	Not available	Not availat
01	Casing, Tri-Clamp® Ports 1" x 1"	R3M-1-01-316	Not available	Not available	Not available	Not availat
01	Casing, Threaded Ports 1½" x 1½"	Not available	R10-1½-01B-316	R25-1½-01B-316	Not available	Not availat
01	Casing, Tri-Clamp Ports 1½" x 1½"	Not available	R10M-1½-01B-316	R25M-1½-01B-316	Not available	Not availat
01	Casing, Threaded Ports 2" x 2"	Not available	Not available	Not available	R60-2-01B-316	Not availat
01	Casing, Tri-Clamp Ports 2" x 2"	Not available	Not available	Not available	R60M-2-01B-316	Not availat
01	Casing, Threaded Ports 2½" x 2½"	Not available	Not available	Not available	Not available	R125-2½-01E
01	Casing, Tri-Clamp Ports 2½" x 2½"	Not available	Not available	Not available	Not available	R125M-2½-01I
01	Casing, Threaded Ports 3" x 3"	Not available	Not available	R25-3-01B-316	R60-3-01BF-316	R125-3-01B-
01	Casing, Tri-Clamp Ports 3" x 3"	Not available	Not available	R25M-3-01B-316	R60M-301BF-316	R125M-3-01E
01	Casing, Threaded Ports 4" x 4"	Not available	Not available	Not available	Not available	Not availat
01	Casing, Tri-Clamp Ports 4" x 4"	Not available	Not available	Not available	Not available	Not availat
01	Casing, Threaded Ports 6" x 6"	Not available	Not available	Not available	Not available	Not availat
01	Casing, Tri-Clamp Ports 6" x 6"	Not available	Not available	Not available	Not available	Not availat
02	Impeller 6 lobe Rubber (Buna N - Cold)	<i>See Ordering Impellers</i>	Not available	Not available	Not available	Not availat
02	Impeller 6 lobe Rubber (Buna N - Hot)	<i>See Ordering Impellers</i>	Not available	Not available	Not available	Not availat
02	Impeller 2 or 4 lobe Rubber (Buna N)	Not available	<i>See Ordering Impellers</i>	<i>See Ordering Impellers</i>	<i>See Ordering Impellers</i>	<i>See Ordering Irr</i>
02	Impeller 2 or 4 lobe Tri-Clover Metal	Not available	<i>See Ordering Impellers</i>	<i>See Ordering Impellers</i>	<i>See Ordering Impellers</i>	<i>See Ordering Irr</i>
06	Pump Shaft	R3-1-06-316	R10-1½-06-316	R25-1½-06-316	R60-2-06-316	R125-2½-06-
08	Impeller Carbon	Not available	R10-1½-08	R25-1½-08	R60-2-08	R60-2-08
09	Front Cover	R3-1-09-316	R10-1½-09-316	R25-1½-09-316	R60-2-09-316	R60-2-09-3
12	Drive Shaft	R3-1-12-316	R10-1½-12-316	R25-1½-12-316	R60-2-12-316	R125-2½-12-
16	Bearing - Inboard	R3-1-16	R10-1½-16	R25-1½-16	R60-2-18	R125-2½-1
18	Bearing - Outboard	R3-1-16	R10-1½-16	R25-1½-16	R60-2-18	R60-2-18
19	Frame	R3-1-19-C	R10-1½-19-C	R25-1½-19-C	R60-2-19-C	R60-2-19-4
22	Locknut	Not available	Not available	Not available	Not available	Not availat
35	Alignment, Locating Ring	R3-1-A35-316L	R10-1½-A35-316L	R25-1½-A35-316L	R60-2-A35-316L	R125-2½-A35-
35A	Alignment Locating Ring O-Ring	R3-1-37A-U	R10-1½-35A-U	R25-1½-35A-U	R60-2-37A	R60-2-37/
37	Bearing Cover Outboard	R3-1-37-CS	R10-1½-37-CS	R25-1½-37-CS	R60-2-37-CS	R60-2-37-C

PR Pump (cont.)

Key	Description	Model 3	Model 10	Model 25	Model 60	Model 12
37A	Bearing Cover O-Ring	R3-1-37A-U	R10-1½-37A-U	R25-1½-37A-U	R60-2-37A	R60-2-37A
46	Coupling Key	R3-1-46	R10-1½-46	R25-1½-46	R60-2-46	R60-2-46
47	Alignment Locating Ring Seal	R3-1-47	R10-1½-47	R25-1½-47	R60-2-47	R125-2½-47
49	Bearing Cover Seal	R3-1-47	R10-1½-47	R25-1½-49	R60-2-47	R60-2-47
58	Plug	MS-105-58	2EBH-105-58	2EBH-105-58	2EBH-105-58	2EBH-105-58
58A	Vented Plug	MS-105-58A	2EBH-105-58A	2EBH-105-58A	2EBH-105-58A	2EBH-105-58A
59	Cleanout Hole Cover	R3-1-59-S	R25-1½-59-S	R25-1½-59-S	R60-2-59-S	R60-2-59-S
59A	Cleanout Hole Gasket	R3-1-59A	R25-1½-59-A	R25-1½-59-A	R60-2-59A	R60-2-59A
59B	Cleanout Hole Screw	SC905H-SS	SC905H-SS	SC905H-SS	SC905H-SS	SC905H-S
69	Lockwasher	Not available	Not available	Not available	Not available	Not availab
73	Gear Cover Gasket	R3-1-73	R10-1½-73	R25-1½-73	R60-2-73	R60-2-73
80-1	Wear Ring	R3-1-80-1-S	R10-1½--80-1-S	R25-1½-80-1-S	R60-2-80-1-S	R60-2-80-1
80-2	Seal Ring	R3-1-80-2	R10-1½--80-2A	R25-1½--80-2A	R60-2-80-2A	R60-2-80-2
80-3	Shaft O-Ring (Buna N)	R3-1-80-3A-U	R10-1½-80-3A-U	R25-1½-80-3A-U	R60-2-80-3A-U	R60-2-80-3A
80-4B	Casing O-Ring (Buna N)	R3-80-4A-U	R10-1½-80-4B-U	R25-1½-80-4B-U	R60-2-80-4B-U	R60-2-80-4E
86	Casing Stud	R3-1-86-S	R10-1½-86-S	R25-1½-86-S	R60-2-86-S	R125-2½-86
86B	Casing Nut	R3-1-86A-S	R25-1½-86B-S	R25-1½-86B-S	R60-2-86B-S	R60-2-86B
90A	Casing Cover O-Ring (Buna N)	R3-1-90B	R10-1½-90B	R25-1½-90B	R60-2-90B	R60-2-90E
93	Alignment Pin	R3-1-93	R25-1½-93	R25-1½-93	R60-2-93	R60-2-93
94A	Timing Gear	R3-1-94A	R10-1½-94A	R25-1½-94A	R60-2-94A	R60-2-94A
96	Timing Gear Key	R3-1-96	R10-1½-96	R25-1½-96	R60-2-96	R60-2-96
98	Gear Retainer Ring	R3-1-98	R10-1½-98	R25-1½-98	R60-2-98	R60-2-98
102	Bearing Retainer Ring	R3-1-102	R10-1½-102	R25-1½-102	R60-2-102	R125-2½-102
128	Tachometer Plug with Gasket	R3-1-128	R10-1½-128	R3-1½-128	R3-1-128	R3-1-128
133	Grease Fitting	R3-1½-133	R10-1½-133	R25-1½-133	R25-1½-133	R25-1½-133
175	Gear Cover	R3-1-175-C	R10-1½-175-C	R25-1½-175-C	R60-2-175-C	R60-2-175-C
175A	Gear Cover Screw	SC912H-S	SC1113H-S	SC1316H-S	SC1519H-S	SC1519H-S
177	Shaft Retainer Ring	R3-1-177	R10-1½-177	R25-1½-177	R60-2-177	R60-2-177
179	Gear Cover Seal	R3-1-179	R10-1½-179	R25-1½-179	R60-2-179	R60-2-179

PARTS LIST

PRE & PRED PUMP

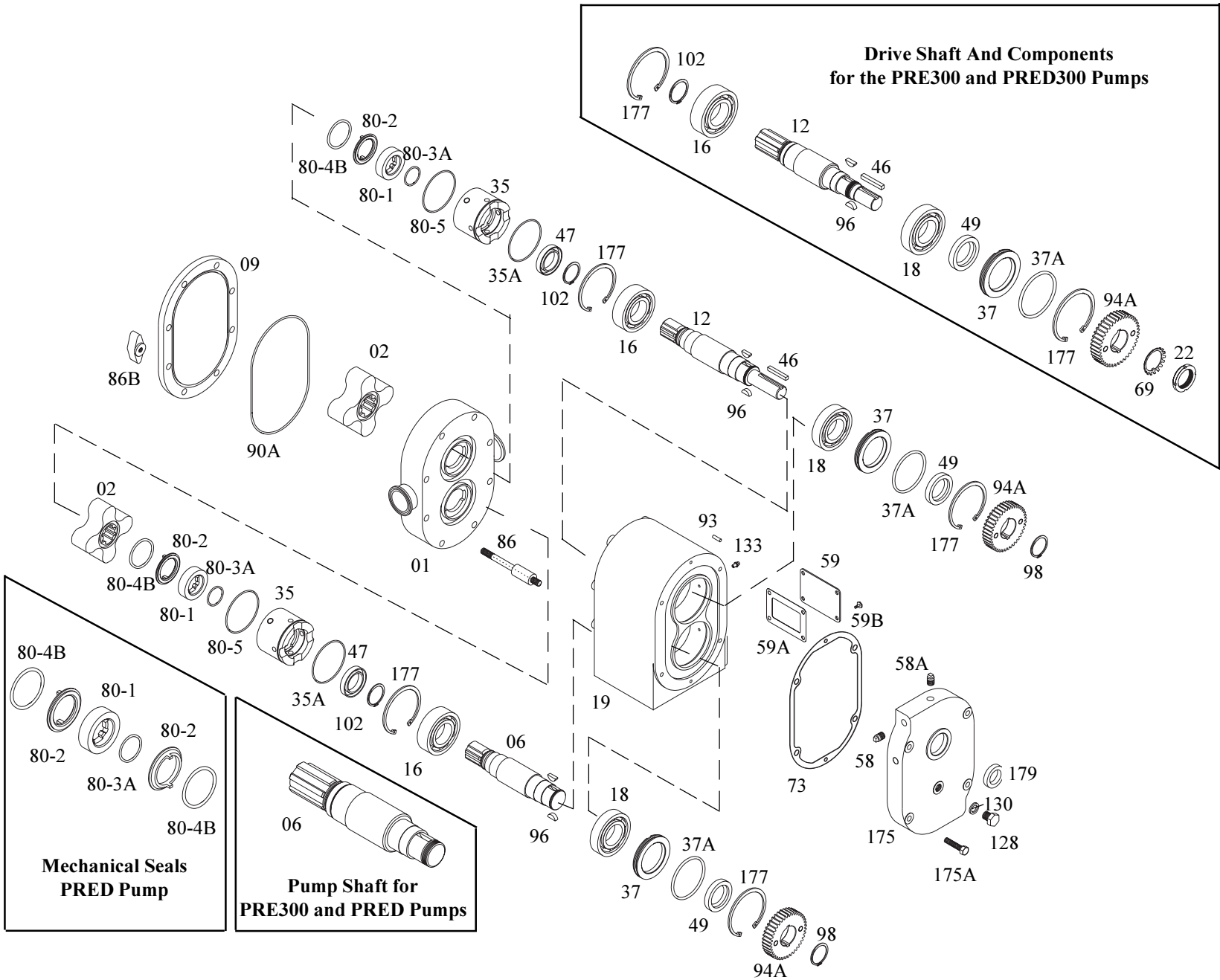

PRE & PRED Pump

Key	Description	Model 3	Model 10	Model 25	Model 60	Model 12
01	Casing, Threaded Ports 1" x 1"	R3-1-01-316	Not available	Not available	Not available	Not availab
01	Casing, Tri-Clamp Ports 1" x 1"	R3M-1-01-316	Not available	Not available	Not available	Not availab
01	Casing, Threaded Ports 1½" x 1½"	Not available	R10-1½-01B-316	R25-1½-01B-316	Not available	Not availab
01	Casing, Tri-Clamp Ports 1½" x 1½"	Not available	R10M-1½-01B-316	R25M-1½-01B-316	Not available	Not availab
01	Casing, Threaded Ports 2" x 2"	Not available	Not available	Not available	R60-2-01B-316	Not availab
01	Casing, Tri-Clamp Ports 2" x 2"	Not available	Not available	Not available	R60M-2-01B-316	Not availab
01	Casing, Threaded Ports 2½" x 2½"	Not available	Not available	Not available	Not available	R125-2½-01E
01	Casing, Tri-Clamp Ports 2½" x 2½"	Not available	Not available	Not available	Not available	R125M-2½-01I
01	Casing, Threaded Ports 3" x 3"	Not available	Not available	R25-3-01B-316	R60-3-01BF-316	R125-3-01B-
01	Casing, Tri-Clamp Ports 3" x 3"	Not available	Not available	R25M-3-01B-316	R60M-301BF-316	R125M-3-01E
01	Casing, Threaded Ports 4" x 4"	Not available	Not available	Not available	Not available	Not availab
01	Casing, Tri-Clamp Ports 4" x 4"	Not available	Not available	Not available	Not available	Not availab
01	Casing, Threaded Ports 6" x 6"	Not available	Not available	Not available	Not available	Not availab
01	Casing, Tri-Clamp Ports 6" x 6"	Not available	Not available	Not available	Not available	Not availab
02	Impeller 6 lobe Rubber (Buna N - Cold)	<i>See Ordering Impellers</i>	Not available	Not available	Not available	Not availab
02	Impeller 6 lobe Rubber (Buna N - Hot)	<i>See Ordering Impellers</i>	Not available	Not available	Not available	Not availab
02	Impeller 2 or 4 lobe Rubber (Buna N)	Not available	<i>See Ordering Impellers</i>	<i>See Ordering Impellers</i>	<i>See Ordering Impellers</i>	<i>See Ordering Irr</i>
02	Impeller 2 or 4 lobe Tri-Clover Metal	Not available	<i>See Ordering Impellers</i>	<i>See Ordering Impellers</i>	<i>See Ordering Impellers</i>	<i>See Ordering Irr</i>
06	Pump Shaft	R3E-1-06-316	R10E-1½-06-316	R25E-1½-06-316	R60E-2-06-316	R125E-2½-06
08	Impeller Carbon	Not available	R10E-1½-08	R25E-1½-08	R60-2-08	R60-2-08
09	Front Cover	R3-1-09-316	R10-1½-09-316	R25-1½-09-316	R60-2-09-316	R60-2-09-3
12	Drive Shaft	R3E-1-12-316	R10E-1½-12-316	R25E-1½-12-316	R60E-2-12-316	R125E-2½-12
16	Bearing - Inboard	R3-1-16	R10-1½-16	R25-1½-16	R60-2-18	R125-2½-1
18	Bearing - Outboard	R3-1-16	R10-1½-16	R25-1½-16	R60-2-18	R60-2-18
19	Frame	R3-1-19-C	R10-1½-19-C	R25-1½-19-C	R60-2-19-C	R60-2-19-4
22	Locknut	Not available	Not available	Not available	Not available	Not availab
35	Alignment, Locating Ring	R3E-1-A35-316L	R10E-1½-A35-316L	R25E-1½-A35-316L	R60E-2-A35-316L	R125E-2½-A3E
35A	Alignment Locating Ring O-Ring	R3-1-37A-U	R10-1½-35A-U	R25-1½-35A-U	R60-2-37A	R60-2-37/
37	Bearing Cover Outboard	R3-1-37-CS	R10-1½-37-CS	R25-1½-37-CS	R60-2-37-CS	R60-2-37-C

PRE & PRED Pump (cont.)

Key	Description	Model 3	Model 10	Model 25	Model 60	Model 12
37A	Bearing Cover O-Ring	R3-1-37A-U	R10-1½-37A-U	R25-1½-37A-U	R60-2-37A	R60-2-37A
46	Coupling Key	R3-1-46	R10-1½-46	R25-1½-46	R60-2-46	R60-2-46
47	Alignment Locating Ring Seal	R3-1-47	R10-1½-47	R25-1½-47	R60-2-47	R125-2½-47
49	Bearing Cover Seal	R3-1-47	R10-1½-47	R25-1½-49	R60-2-47	R60-2-47
58	Plug	MS-105-58	2EBH-105-58	2EBH-105-58	2EBH-105-58	2EBH-105-58
58A	Vented Plug	MS-105-58A	2EBH-105-58A	2EBH-105-58A	2EBH-105-58A	2EBH-105-58A
59	Cleanout Hole Cover	R3-1-59-S	R25-1½-59-S	R25-1½-59-S	R60-2-59-S	R60-2-59-S
59A	Cleanout Hole Gasket	R3-1-59A	R25-1½-59-A	R25-1½-59-A	R60-2-59A	R60-2-59A
59B	Cleanout Hole Screw	SC905H-SS	SC905H-SS	SC905H-SS	SC905H-SS	SC905H-SS
69	Lockwasher	Not available	Not available	Not available	Not available	Not available
73	Gear Cover Gasket	R3-1-73	R10-1½-73	R25-1½-73	R60-2-73	R60-2-73
80-1	Wear Ring	R3E-1-80-1-S	R10E-1½--80-1-S	R25E-1½-80-1-S	R60E-2-80-1-S	R60E-2-80-1-S
80-2	Seal Ring	R3E-1-80-2	R10E-1½--80-2A	R25E-1½--80-2A	R60E-2-80-2A	R60E-2-80-2A
80-3	Shaft O-Ring (Buna N)	R3-1-80-3A-U	R10-1½-80-3A-U	R25-1½-80-3A-U	R60-2-80-3A-U	R60-2-80-3A-U
80-4B	Casing O-Ring (Buna N)	R3-80-4A-U	R10-1½-80-4B-U	R25-1½-80-4B-U	R60-2-80-4B-U	R60-2-80-4B-U
80-5	O-Ring (Buna)	17-125-U	17-25-U	17-7-U	R60-2-37A	R60-2-37A
86	Casing Stud	R3E-1-86	R10E-1½-86-S	R25E-1½-86-S	R60E-2-86-S	R125E-2½-86-S
86B	Casing Nut	R3-1-86A-S	R25-1½-86B-S	R25-1½-86B-S	R60-2-86B-S	R60-2-86B-S
90A	Casing Cover O-Ring (Buna N)	R3-1-90B	R10-1½-90B	R25-1½-90B	R60-2-90B	R60-2-90B
93	Alignment Pin	R3-1-93	R25-1½-93	R25-1½-93	R60-2-93	R60-2-93
94A	Timing Gear	R3-1-94A	R10-1½-94A	R25-1½-94A	R60-2-94A	R60-2-94A
96	Timing Gear Key	R3-1-96	R10-1½-96	R25-1½-96	R60-2-96	R60-2-96
98	Gear Retainer Ring	R3-1-98	R10-1½-98	R25-1½-98	R60-2-98	R60-2-98
102	Bearing Retainer Ring	R3-1-102	R10-1½-102	R25-1½-102	R60-2-102	R125-2½-102
128	Tachometer Plug with Gasket	R3-1-128	R10-1½-128	R3-1½-128	R3-1-128	R3-1-128
133	Grease Fitting	R3-1½-133	R10-1½-133	R25-1½-133	R25-1½-133	R25-1½-133
175	Gear Cover	R3-1-175-C	R10-1½-175-C	R25-1½-175-C	R60-2-175-C	R60-2-175-C
175A	Gear Cover Screw	SC912H-S	SC1113H-S	SC1316H-S	SC1519H-S	SC1519H-S
177	Shaft Retainer Ring	R3-1-177	R10-1½-177	R25-1½-177	R60-2-177	R60-2-177
179	Gear Cover Seal	R3-1-179	R10-1½-179	R25-1½-179	R60-2-179	R60-2-179