

F4329 Blender

10

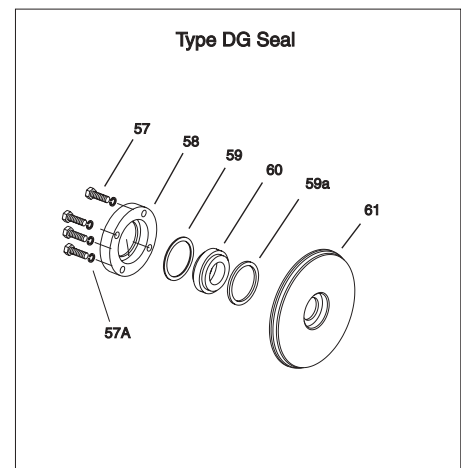
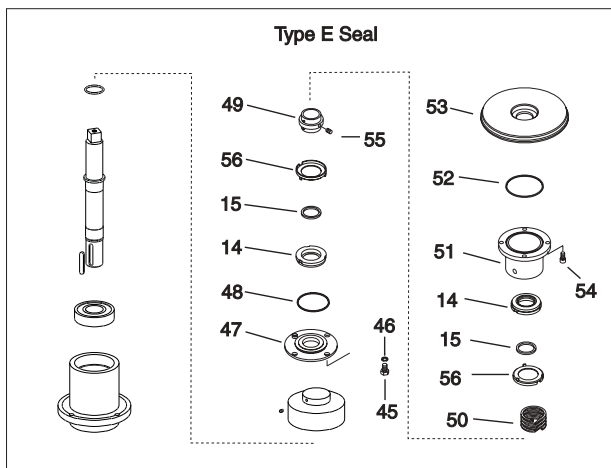
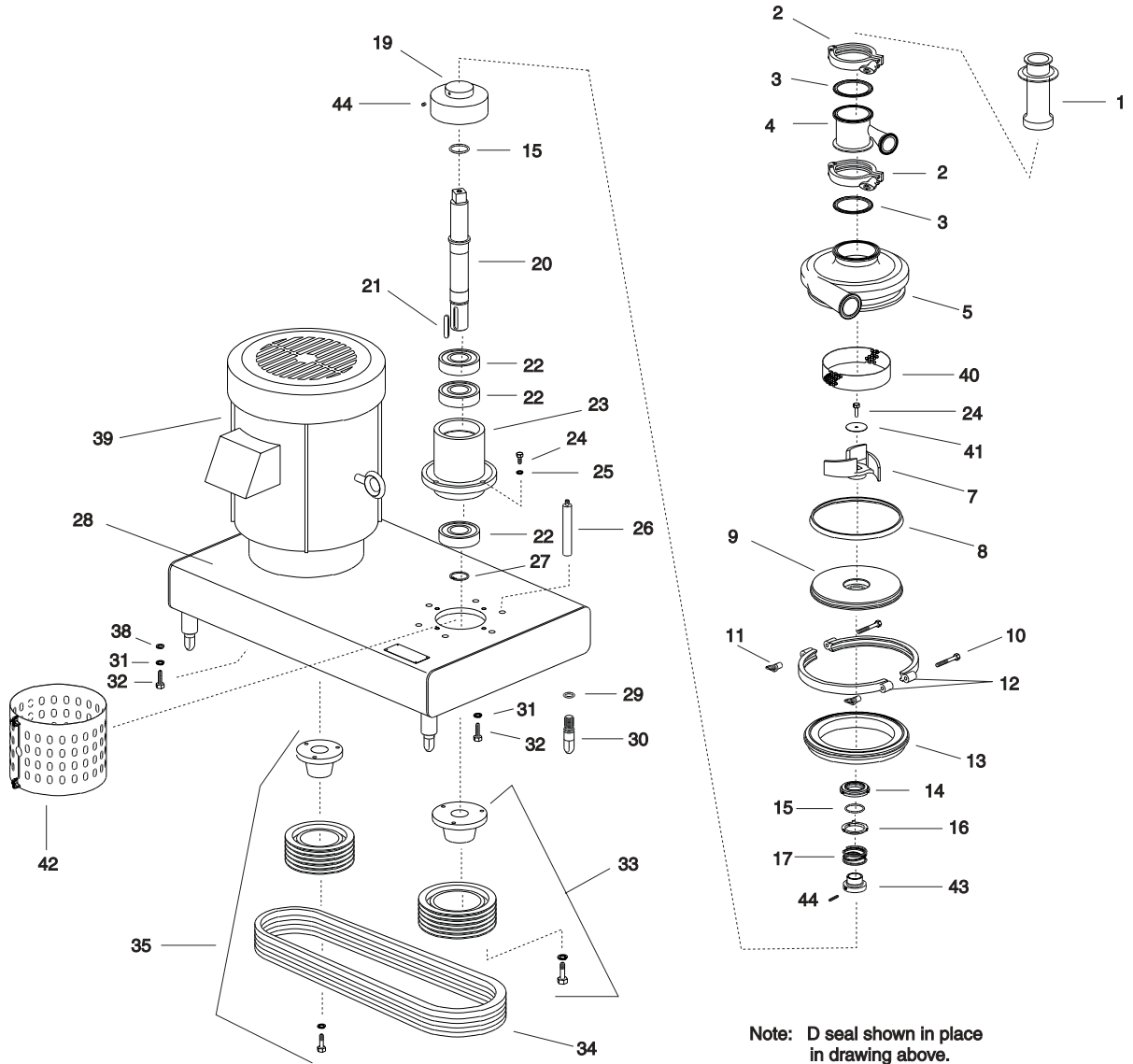

Pos.	Qty.	Denomination	Code No.
1	1	Diffuser & suction tube	540129
2	2	Clamp	212211
3	2	Gasket	298360
4	1	Inlet adapter	540130
5	1	Casing	540135
7	1	Impeller	540261
8	●○	Gasket BUNA	488389
8	●○	Gasket EPDM	480729
8	●○	Gasket SFY	480861
9	1	Backplate D-seal	488103
12	1	Clamp	481624
13	1	Adapter ring	540115
14	●○	Carbon seal	480525
15	●○	Seal O-ring BUNA	480479
15	●○	Seal O-ring EPDM	480226
15	●○	Seal O-ring SFY	480656
16	●	Cup D-seal	484362
17	●	Spring D-seal	484363
19	1	Deflector	540046
20	1	Drive shaft	540262
21	1	Key-pulley	540048
22	3	Sealed bearing	540034
23	1	Bearing housing	540119
24	5	Capscrew-housing	189846
25	4	Lockwasher-housing	189968
26	6	Spacer	540142
27	1	Retaining ring	540059
28	1	Base	540226
29	4	O-ring, leg	296257
30	4	Adjustable leg	580022
31	10	Lockwasher-spacer	189971
32	10	Capscrew-spacer	189888
33	1	60 cycle blender sheave	540280
33	1	50 cycle blender sheave	540324
34	4	Drive belt	540221
35	1	60 cycle motor sheave	540281
35	1	50 cycle motor sheave	540281
36	2	Capscrew	189842
37	2	Lockwasher	189942
38	4	Washer	189952
39	1	30 hp tefc reliance 286tc	190346
40	1	Screen	540144
41	1	Impeller washer	540216
42	1	Seal guard	540263
43	1	Drive collar D-seal	480864
44	1	Set screw D-seal drive collar	189840
45	4	Screw E-seal follower	189773
46	4	Lockwasher E-seal follower	189962

- included in D seal service kits
- included in E seal service kits
- included in DG seal service kits

- Buna 9613990420
- EPDM 9613990421
- SFY 9613990422
- Buna 9613990423
- EPDM 9613990424
- SFY 9613990425
- SC 9613990417
- CER 9613990418
- TC 9613990419

F4329 Blender

12

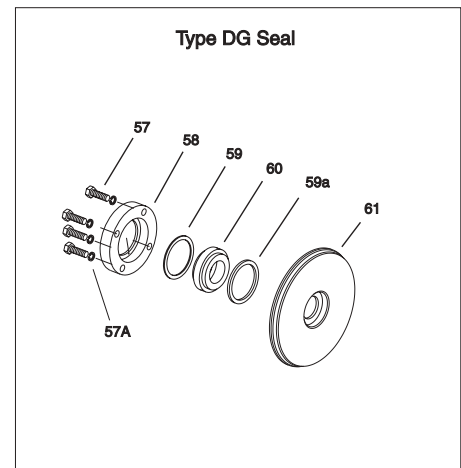
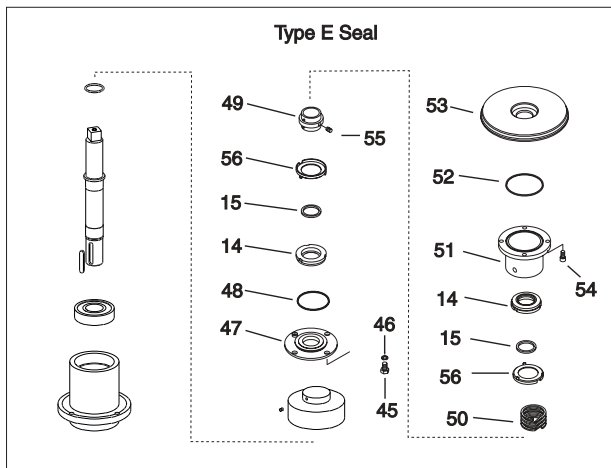
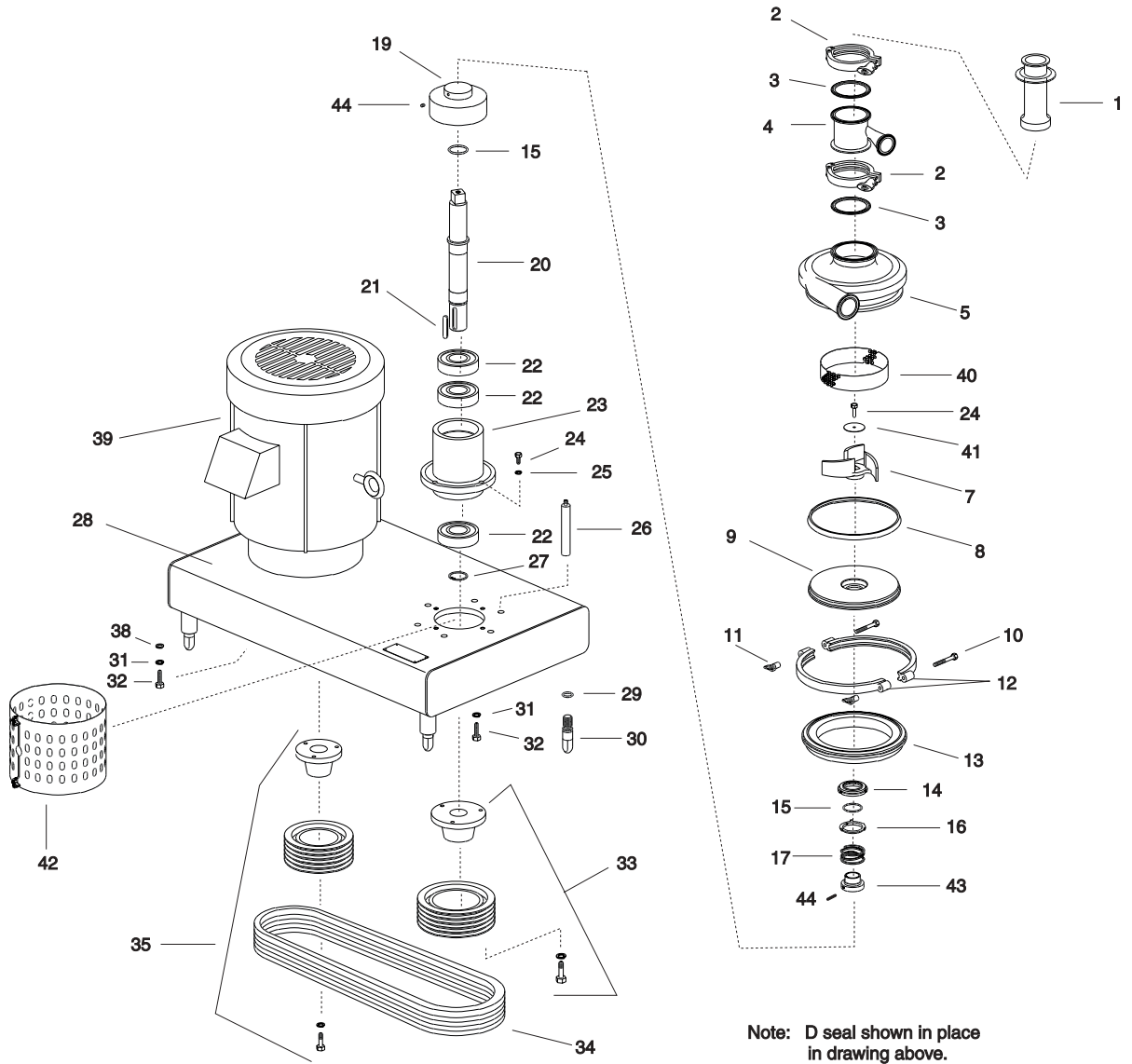

Pos.	Qty.	Denomination	Code No.
47	4	Follower	481211
48	○	Follower O-ring BUNA	751297
48	○	Follower O-ring EPDM	751634
48	○	Follower O-ring SFY	751307
49	1	Drive collar E-seal	481212
50	○	Spring E-seal	481210
51	1	Stuffing box E-seal	540232
52	○	Stuffing box O-ring BUNA	755528
52	○	Stuffing box O-ring EPDM	750575
52	○	Stuffing box O-ring SFY	751306
53	1	Backplate E-seal	482455
54	1	Screw stuffing box	180352
55	4	Set screw E-seal drive collar	189819
56	○	Cup E-seal	481209
57	4	Screw DG gland ring	189849
57A	4	Washer DG gland ring	189961
58	1	Gland ring	480050
59	■	PTFE gasket-outboard	481522
59A	■	PTFE gasket-inboard	482809
60	■	DG seal seat (cer)	480238
60	■	DG seal seat (sc)	481470
60	■	DG seal seat (tc)	480466
61	1	Backplate DG seal	480078

- included in D seal service kits
- included in E seal service kits
- included in DG seal service kits

- Buna 9613990420
- EPDM 9613990421
- SFY 9613990422
- Buna 9613990423
- EPDM 9613990424
- SFY 9613990425
- SC 9613990417
- CER 9613990418
- TC 9613990419