

Centrifugal Pump FM-OS (GHC-0) Single Shaft Seal

Pos.	Qty.	Description
1	1	Motor T.E.F.C. 0.25 - 0.5 HP/1800RPM
	1	Motor T.E.F.C. 0.50 - 2.0 HP/3600RPM
2	4	Screw9611-99-1495
3	4	Washer41381
4	1	Bracket31457-0079-1
5	1	Yoke - Ind31457-0050-1
	1	Yoke - 3A31457-0050-3
6	1	Impeller - Ind31457-0018-1
	1	Impeller - 3A31457-0018-4
7	1	Casing-GC Ind31457-0134-3
	1	Casing-GC 3A31456-0050-4
	1	Casing-Bevel Seat 3A31457-0087-2
8	2	Wing Nut31336-0143-2
9	1	Backplate - Ind31456-0035-1
	1	Backplate - 3A31456-0035-2
10	1	Joint Ring, EPDM (Std.)2234121-75
	1	Joint Ring, Viton223412-76
	1	Joint Ring, PTFE31456-0060-1
11	2	Stud Bolt31457-0051-4
21	1	Thrower31457-0025-2
24	1	Nut31437-0120-1
26	1	Shaft 0.25 - 1.0 HP31457-0080-2
	1	Shaft 1.5 - 2.0 HP31457-0080-1
28	3	Set Screw881185049
30	1	Right Support Bar31460-1287-1
31	1	Left Support Bar31460-1288-1
32	4	Screw9611-99-1907
33	4	Leg31460-1018-1
34	4	Screw2217755-25
35	4	Lock Washer68750
36	4	Acorn Cap Nut221851-14
37	1	Shaft Pin9611-99-1822
		Shaft seal, compl., Nitrile (Std.)31439-0164-6
22	1	Spring31438-0057-1
23	1	Stationary seal ring31437-0119-2
25	1	Packing31437-0121-1
27	1	Rotating seal ring31439-0165-1
29	1	O-ring31439-0168-1
		Shaft seal, compl., EPDM31439-0164-8
22	1	Spring31438-0057-1
23	1	Stationary seal ring SC31437-0225-2
25	1	Packing31437-0121-3
27	1	Rotating seal ring31439-0165-1
29	1	O-ring31439-0168-4
		Shaft seal, compl., Viton31439-0164-9
22	1	Spring31438-0057-1
23	1	Stationary seal ring31437-0119-2
25	1	Packing31438-0121-3
27	1	Rotating seal ring31439-0165-1
29	1	O-ring31439-0168-5
		Shaft seal, compl., Teflon31439-0167-7
22	1	Spring31438-0057-1
23	1	Stationary seal ring31437-0119-2
25	1	Packing31437-0121-3
27	1	Rotating seal ring31439-0165-1
29	1	O-ring31439-0168-3
		For abrasive liquids
23	1	Stationary seal ring with silicon carbide31437-0225-2
27*	1	Rotating seal ring with silicon carbide31439-0165-4

*The rotating seal ring with silicon carbide must not be used together with a stationary seal ring of stainless steel.

Recommended spare parts: Pos. 10 and complete shaft seals.

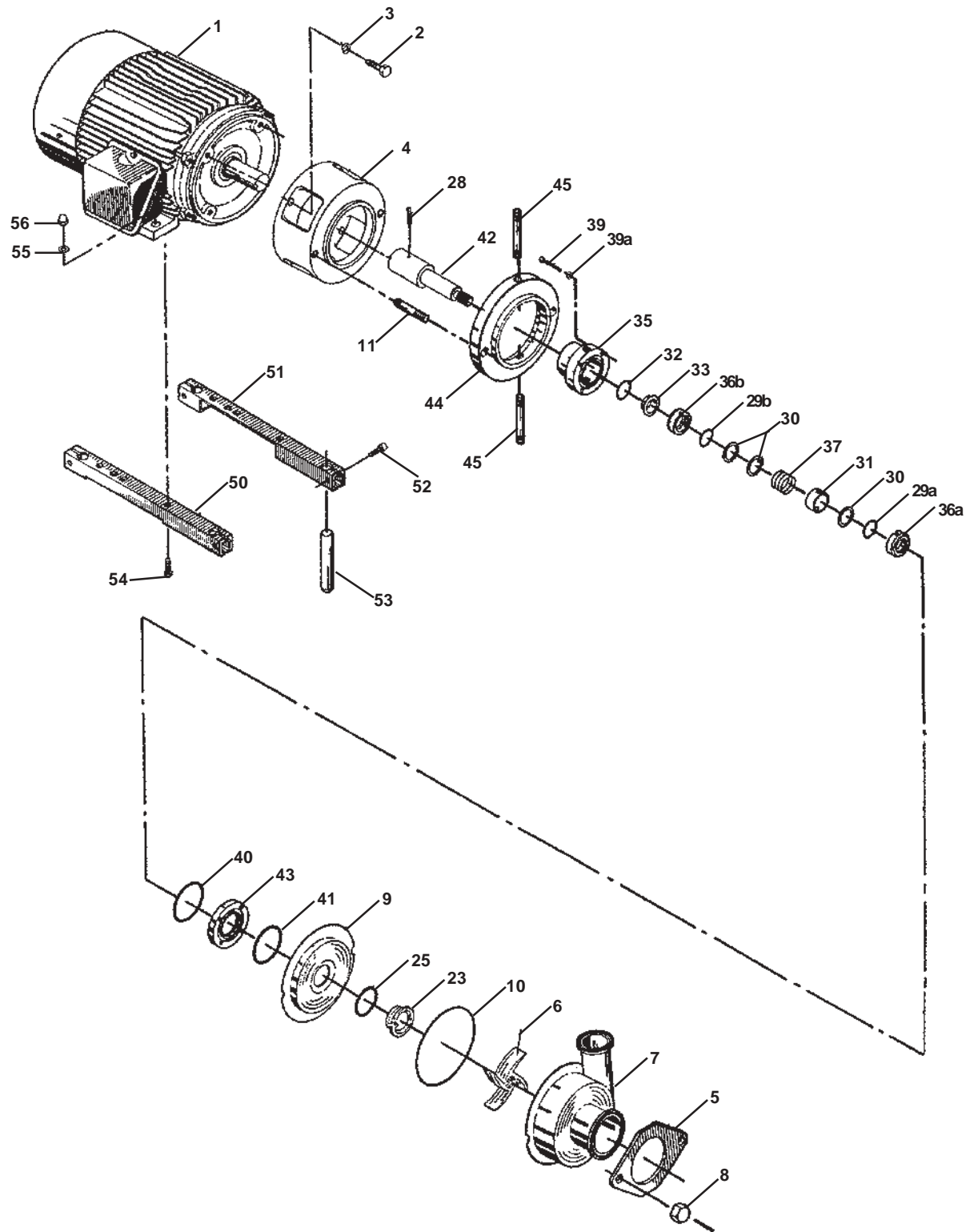

Pos.	Qty.	Description	
1	1	Motor T.E.F.C. 0.25 - 0.5 HP/1800RPM	
	1	Motor T.E.F.C. 0.50 - 2.0 HP/3600RPM	
2	4	Screw	2217759-25
3	4	Washer	41381
4	1	Bracket	31457-0079-1
5	1	Yoke - Ind	31457-0050-1
	1	Yoke - 3A	31457-0051-3
6*	1	Impeller - Ind	31457-0018-1
	1	Impeller - 3A	31457-0018-4
7	1	Casing-GC Ind	31457-0038-4
	1	Casing-GC 3A	31457-0087-1
	1	Casing-Bevel Seat 3A	31457-0087-2
8	2	Wing Nut	31336-0143-2
9	1	Backplate - Ind	31456-0035-1
	1	Backplate - 3A	31456-0035-2
10	1	Joint Ring, EPDM (Std.)	2234121-75
	1	Joint Ring, Viton	223412-76
	1	Joint Ring, PTFE	31456-0060-1
11	2	Stud Bolt	31457-0051-4
31	1	Spacer	31437-0212-1
34	3	Set Screw	88115049
35	1	Seal Housing	31439-0114-1
39	4	Screw	9611-99-0333
42	1	Shaft 0.25 -1.0 HP	31457-0081-2
	1	Shaft 1.5 - 2.0 HP	31457-0081-1
43	1	Fastening Ring	31439-0113-1
44	1	Intermediate Flange	31457-0082-1
45	2	Pipe	9612-3589-01
50	1	Right Support Bar	31460-1287-1
51	1	Left Support Bar	31460-1288-1
52	4	Screw	9611-99-1907
53	4	Leg	31460-1018-1
54	4	Screw	2217755-25
55	4	Lock Washer	68750
56	4	Acorn Cap Nut	221851-14

*Sometimes reduced impeller dimensions. Check the dimensions of the original impeller.

		Shaft seal, compl., Nitrile	31439-0166-1
		Shaft seal, compl., EPDM	31439-0166-4
		Shaft seal, compl., Viton	31439-0166-5
		Shaft seal, compl., Teflon	2700-674
23	1	Stationary seal ring for shaft seal complete Nitrile, Viton, Teflon	9612-3758-01
25	1	Packing for shaft seal complete Nitrile	31437-0121-1
29a	1	O-ring, front for shaft seal complete Nitrile, Teflon	31439-0168-1
29b	1	O-ring, back for shaft seal complete Nitrile, Teflon	31439-0168-1
30	3	Washer for shaft seal complete Nitrile, Viton, Teflon	104125
32	1	O-ring for shaft seal complete Nitrile, EPDM, Viton, Teflon	223406-51
33	1	Stationary seal ring for shaft seal complete Nitrile, EPDM, Viton, Teflon	31450-0007-1
36	2	Rotating seal ring for shaft seal complete Nitrile, EPDM, Viton, Teflon	31437-0122-1
37	1	Spring for shaft seal complete Nitrile, EPDM, Viton, Teflon	104154
40	1	O-ring for shaft seal complete Nitrile, EPDM, Viton	223406-60
41	1	O-ring for shaft seal complete Nitrile, EPDM, Viton, Teflon	223406-58
23	1	Stationary seal ring for shaft seal complete EPDM	9612375801
25	1	Packing for shaft seal complete EPDM, Viton, Teflon	31437-0121-3
29a	1	O-ring, front for shaft seal complete EPDM	31439-0168-4
29b	1	O-ring, back for shaft seal complete EPDM	31439-0168-4
30	3	Washer for shaft seal complete EPDM	104126
29a	1	O-ring, front for shaft seal complete Viton	31439-0168-5
29b	1	O-ring, back for shaft seal complete Viton	31439-0168-5

For abrasive liquids

23	1	Stationary seal ring with silicon carbide	31437-0225-1
36*	1	Rotating seal ring with silicon carbide	31437-0211-4

*The rotating seal ring with silicon carbide must not be used together with a stationary seal ring of stainless steel

Recommended spare parts: Pos. 10 and complete shaft seals.

Alfa Laval

8201 104th Street
Pleasant Prairie, WI 53158-0909
Telephone: 800-558-2060
Fax: 262-947-4724
www.alfalaval.com