

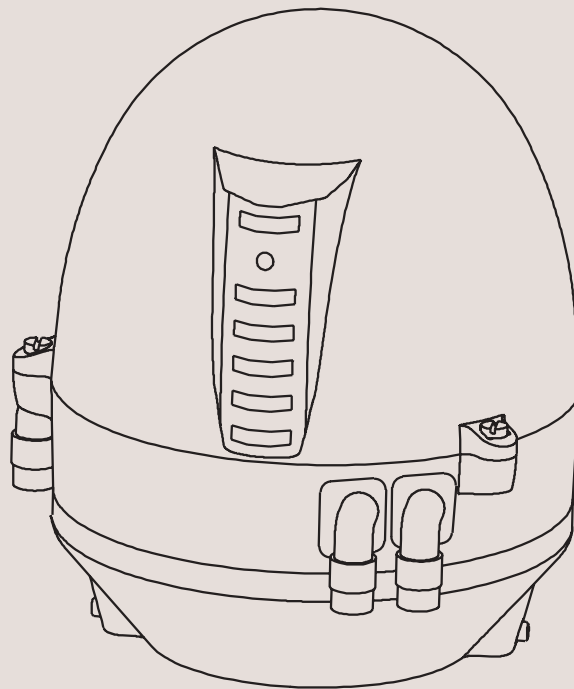

Instruction Manual

ThinkTop® DeviceNet™ 11-25 VDC

DeviceNet™
CONFORMANCE TESTED



Declaration of Conformity

The designating company

Alfa Laval

Company Name

Albuen 31, DK-6000 Kolding, Denmark

Address

+45 79 32 22 00

Phone No.

hereby declare that

Top Unit for Valve Control & Indication

Denomination

ThinkTop® DeviceNet™

Type

Year

is in conformity with the following directives with amendments:

- Low Voltage Directive 73/23/EEC
- EMC Directive 89/336/EEC

Vice President, R & D

Title

Bjarne Søndergaard

Name

Alfa Laval

Company

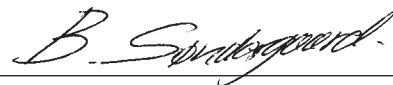

Signature

Designation



The information contained herein is correct at the time of issue but may be subject to change without prior notice.

1. Safety	6
1.1 Important information	6
1.2 Warning signs	6
1.3 Safety precautions	6
2. General information	7
2.1 DeviceNet _{TM} in general	7
3. Technical specifications	8
3.1 <i>ThinkTop</i> [®] DeviceNet _{TM} features	9
4. Installation	17
4.1 Installation on air actuators	17
4.2 Installation on Series 700 valves	20
4.3 Air connections	21
4.4 Electrical connection, internal	22
5. Setup diagram	24
5.1 <i>ThinkTop</i> [®] setup utilising IR keypad	24
5.2 <i>ThinkTop</i> [®] setup utilising local 'I' and 'II' keys	26
6. Fault finding	28
6.1 Fault finding and LEDs	28
7. Maintenance	30
7.1 Dismantling of <i>ThinkTop</i> [®]	30
7.2 Assembly of <i>ThinkTop</i> [®]	32
7.3 Dismantling and assembly of Series 700 valves	34
8. Parts list	36
8.1 <i>ThinkTop</i> [®] DeviceNet _{TM} 11-25 VDC	36
8.2 <i>ThinkTop</i> [®] Series 700 valves	38

1.1 Important information

1.2 Warning signs

1.3 Safety precautions

Unsafe practices and other important information are emphasized in this manual.

Warnings are emphasized by means of special signs.

All warnings in the manual are summarized on this page.

Pay special attention to the instructions below so that severe personal injury or damage to the top unit are avoided.

Always read the manual before using the top unit!

WARNING!

Indicates that special procedures **must** be followed to avoid severe personal injury.

CAUTION!

Indicates that special procedures **must** be followed to avoid damage to the *ThinkTop*[®].

NOTE!

Indicates important information to simplify or clarify practices.

General warning:



Dangerous electrical voltage:



Caustic agents:



Installation

- **Always** observe the technical specifications (see chapter 3).
- **Never** install the *ThinkTop*[®] before valve or relay is in a safe position.
- If welding close to the *ThinkTop*[®]: **Always** earth close to the welding area.
- Disconnect the *ThinkTop*[®].
- **Always** have the *ThinkTop*[®] electrically connected by authorized personnel.



Maintenance

- **Always** read the technical specifications thoroughly (see chapter 3).
- **Always** fit the seals between valve and *ThinkTop*[®] correctly.
- **Never** service the *ThinkTop*[®] before valve or relay is in a safe position.
- **Never** service the *ThinkTop*[®] with valve/actuator under pressure.
- **Never** clean the *ThinkTop*[®] with high pressure cleaning equipment.
- **Never** use cleaning agents when cleaning the *ThinkTop*[®]. Check with cleaning agent supplier.



DeviceNet_{TM} is a low-cost communication link to connect industrial devices (such as limit switches, photoelectrical sensors, valve manifolds, motor starters, process sensors, bar code readers, variable frequency drives, panel displays and operator interfaces) to a network and eliminate expensive hardwiring. The direct connectivity provides improved communication between devices as well as important device-level diagnostics not easily accessible or available through hardwired I/O interfaces. DeviceNet_{TM} is a simple networking solution that reduces costs as well as time to wire and install industrial automation devices, while providing interchangeability of similar components from multiple vendors.

DeviceNet_{TM} is an *open network standard*.

DeviceNet_{TM} Features and Functionality:

Network Size	Up to 63 nodes	
Network Length	Selectable end-to-end network distance varies with speed	
	Baud Rate	Distance
	125 Kbps	500 m (1,640 ft)
	250 Kbps	250 m (820 ft)
	500 Kbps	100 m (328 ft)
Data Packets	0-8 bytes	
Bus Topology	Linear (trunk line/drop line); power and signal on the same network cable	
Bus Addressing	Peer-to-Peer with Multi-Cast (one-to-many); Multi-Master and Master/Slave special case; polled or change-of-state (exception-based)	
System Features	Removal and replacement of devices from the network under power	

The basic trunk line/drop line topology provides separate twisted pair busses for both signal and power distribution. Thick or thin cable can be used for either trunk lines or drop lines. End-to-end network distance varies with data rate and cable size.

Data Rates	125 Kbps	250 Kbps	500 Kbps
Thick Trunk Length	500 m (1,640 ft)	250 m (820 ft)	100 m (328 ft)
Thin Trunk Length	100 m (328 ft)	100 m (328 ft)	100 m (328 ft)
Maximum Drop Length	6 m (20 ft)	6 m (20 ft)	6 m (20 ft)
Cumulative Drop Length	156 m (512 ft)	78 m (256 ft)	39 m (128 ft)

The end-to-end network distance varies with data rate and cable thickness.

DeviceNet_{TM} requires a terminating resistor to be installed at each end of the trunk:

- 121 ohm
- 1% metal film
- 1/4 Watt

Terminating resistors should not be installed at the end of a drop line, only at the two ends of the trunk line.

For further information please see the DeviceNet_{TM} Standard.

DeviceNet™ Features

Device Type	Generic	Master/scanner	N
Explicit peer to peer messaging	N	I/O Slave messaging	
I/O peer to peer messaging	N	• Bit strobe	N
Configuration consistency value	N	• Polling	Y
Faulted node recovery	N	• Cyclic	N
Baud rates	125K, 250K, 500K	• Change of state (COS)	Y
Configuration method	EDS		

Special DeviceNet™ functions**Class 100 Attributes**

- Setup commands
- Configuration
- Alarm setup
- Time Total
- Time Closed
- Time Open
- Time to maintenance
- Last stroke travel time
- Last stroke travel length (mm)
- Current position [mm] (0 - 80 mm)
- Activation's solenoid no. 1
- Activation's solenoid no. 2
- Activation's solenoid no. 3
- Open count
- Closed count
- Time of last maintenance

See also section 3.1.4 "ThinkTop® DeviceNet™ Attribute List".

DeviceNet™ interface

Baud rates: 125k, 250K and 500k.

Polling and change of state (COS) I/O slave messaging.

Poll: 7 or 2 bytes (optional).

2 bytes = Input/outputs and alarms (class 4).

7 bytes = Input/outputs alarms and class 100/attributes.

7 bytes is standard.

Changing from 7 bytes to 2 bytes: remove jumper (#12 and #13). A power recycle is necessary when changing byte sizes.

COS: 2 bytes, 7 bytes is not supported.

Node address

Range: 0 – 63.

Default slave address: 63.

Power supply

The power supply to the complete unit is taken from the DeviceNet.

Supply voltage: 11 – 25 V DC, as specified for the DeviceNet.

Supply current: Max. 45 mA (for sensor unit alone)

(excluding current to the solenoids and the external proximity switches).

Electrical connection: Direct cable gland entry (hard wired) PG11 (ø4 - ø10 mm).

3.1.1 “No Touch” sensor system

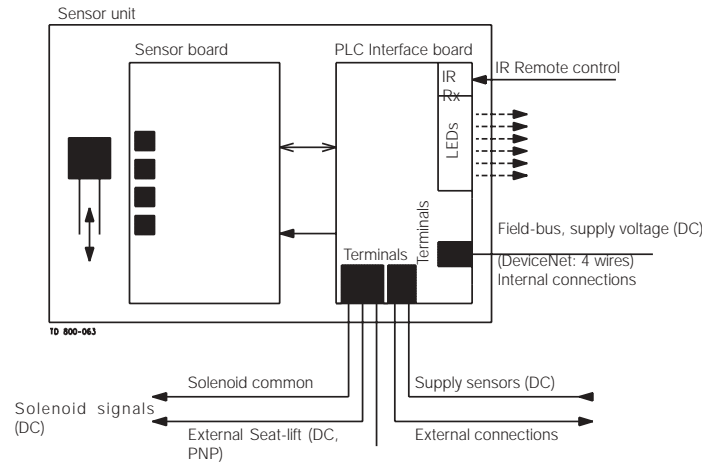

Type: Alfa Laval “No Touch” Sensor System

For wire connections: See section 4.4 “Electrical connection, internal”.

Features

- Tolerance programmes.
- Self adjustment programme (SRC/ARC valves only).
- Built-in maintenance monitor.
- Setup by internal pushbuttons or remote control (IR Keypad).
- Setup and local fault supervision.
- Setup saved at power shutdown.
- Visual LED Indicator lights.

Sensor System

Unique “No Touch” sensor system without any mechanical sensor adjustments. A magnet is mounted on the valve stem and the magnetic field (axial) is detected by sensor chips inside the sensor unit. The measuring angle from each chip is used to locate the current position of the valve stem with an accuracy of ± 0.1 mm. Note that the distance to the magnet can be 5 mm \pm 3 mm.

Feedback signals

Input signals (produced by the sensor unit) transmitted over the DeviceNet™ - class 4.

Five feedback signals: Closed valve, open valve, seatlift 1, seatlift 2 and status.

The status signal is used for five purposes:

- To indicate that a setup is in progress (LED D).
- To indicate an error condition (LED D), (flashing = software error), (steady = hardware error).
- To indicate that maintenance is required (LED F).
- To indicate if there is a conflict in the self adjustment programme (LED F).
- To indicate if no communication exists between ThinkTop® and PLC (LED D, steady).

Tolerance programme:

Individual according to valve types.

- Type 1: SRC/ARC and Series 700 valves.
- Type 2: LKB (LKLA-T).
- Type 3: *Unique*, SMP-SC Spillage-Free, SRC-PV and AMP.
- Type 4: SMP-SC, SMP-TO, SMP-BC, SMP-BCA and SBV.
- Type 0: (Preset) All Parameters Set To Default (also valid for MH Koltek valve and SMP-EC
(¹ seat-lift indication not possible for SMP-EC)).

Preset and reset values: Tolerance programme No. 0 (\pm 5mm) and all functions are disabled.

NOTE! Important to select the right tolerance programme.

Self Adjustment (SRC/ARC valves only)

The self adjustment feature is an exceptional aspect of the *ThinkTop*® design. A programme can be activated to allow an adjustment of the tolerance band if the seals in the valve are being compressed or are worn. When the tolerance band of the unit has been adjusted 0.3 mm, an alert warning will appear in the form of a status signal and a flashing maintenance LED. After 0.5 mm adjustment an alarm warning appears: Loss of feedback signal, status signal and steady maintenance light indicating a minimum of seal left requiring a replacement of the seal.

Built-in Maintenance Monitor

The unit can be preset to indicate when the time for maintenance of the valve has been reached. A status signal and flashing maintenance LED can be programmed to return after 3, 6, 9 or 12 months or more.

Sensor system

Sensor accuracy: $\pm 0,1$ mm.

Distance to magnet: 5 ± 3 mm.

Stroke length: 0.1 - 80 mm.

Terminals

The terminal row of the sensor unit is equipped with screw terminals for both internal as well as external cables and wires. The terminals are suitable for wires up to 0.75 mm² (AWG 19).

External sensors

The external sensors are used for seatlift supervision when seatlift cannot be internally detected. The sensors get their supply voltage from the sensor unit. They connect directly to the terminal strip on the sensor unit. If the actual setup is for internal seatlift, the corresponding external signal is not used. Otherwise the external signal logically controls the corresponding feedback to the bus interface unit.

Supply voltage: Must match the network power.

Supply current: Max. 15 mA per sensor.

Type of sensor: 3-wire PNP-type.

Cable length: Max. 3 m.

Alarm mask

Output signals received from the DeviceNet™ (consumed by the sensor unit).

Four-bit mask to disable the alarm functions for the states "closed", "open", "seatlift 1" and "seatlift 2" respectively.

See also section 3.1.4 "*ThinkTop*® DeviceNet™ Attribute List".

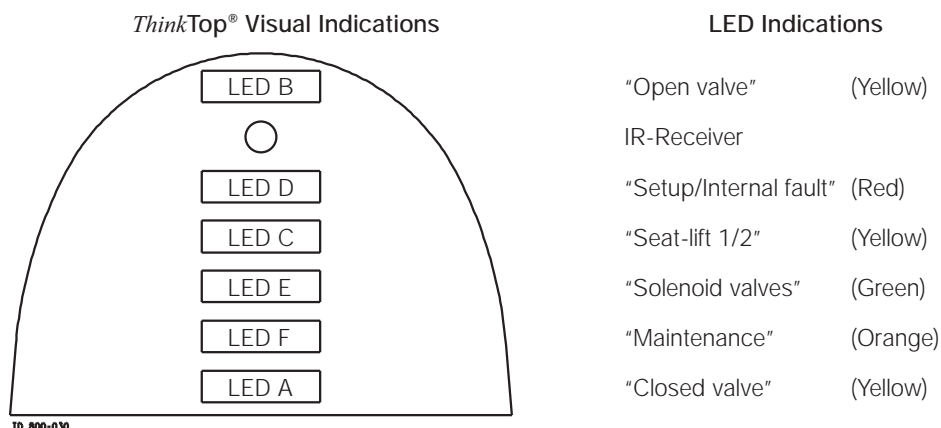
**Feedback signals:**

Signal: "Closed valve".

Signal: "Open valve".

Signal: "Seatlift 1".

Signal: "Seatlift 2".

Signal: "Status".

For wire connections: see section 4.4 "Electrical connection, internal".

Note: If the programmer wishes to detect a physically closed valve position in an "open valve" sensor position, then there is no longer any consistence between the sensor valve detection position and the visual indications of the *ThinkTop*®.

3.1.2 Technical specifications solenoid valves

Solenoid signals

Output signals received from the DeviceNet_{TM} (consumed by the sensor unit) - class 4.
Three bits to control the solenoid drives located in the sensor unit.

Internal connections (solenoids)

The solenoid drivers are reducing the solenoid power by PWM after activation. The number of solenoids actually mounted in the control head could be 0 - 3.

Technical specifications	
Up to 3 solenoid valves in each unit.	
Type	3/2 or 5/2 valve (only possible with one 5/2 valve).
Air supply	300-900 kPa (3-9 bar).
Filtered air, max. particles or dirt	0.01 mm.
Max. flow	180 l/min.
Max. oil content	1.0 ppm.
Max. water content	0.0075 kg/kg air.
Throughput	ø2.5 mm.
Air restriction (throttle function) air inlet/outlet.	
Manual hold override.	
External air tube connection	ø6 mm or 1/4" (specify when ordering).
Silencer/filter *)	Connection possible via ø6 mm or 1/4".
Solenoid drive	
Solenoid valve	8 VDC
O/P Voltage	9 VDC +/- 5%
Power consumption	0.75W Max.
Current consumption (per solenoid)	30mA Max.
PWM Pull-in pulse length	150ms Max.
PWM duty cycle	40% +/- 10%
PWM frequency	2 kHz +/- 10%
PWM = Pulse width modulated	
*) Note! Filter recommended in tropical regions.	

3.1.2.1 Technical specifications aux. outputs

Three aux. outputs can be used for external devices. The drivers are always NPN outputs and PWM mode is not possible. The number of aux. outputs for activation of external devices can be 0-3. Clarification: All 3 outputs can be activated at the same time but if solenoid 1 is in use, aux. 1 can not be used! If solenoid 1 and 2 are in use, aux. 1 and 2 can not be used! If solenoid 1, 2 and 3 are in use, no aux. can be used! A mix of solenoid and aux. outputs is possible.

Output: NPN (sinking).

Output voltage: 24 VDC ± 15%. Network power connection! User must ensure 24 VDC on the network (at the top) when these outputs are used.

Load current: Max 75 mA.

As these outputs drive constant current, using several nodes in this mode will reduce the number of nodes supported by a typical 8A network supply. The user must ensure that total network current consumption is less than the supply rating.

3.1.3 ThinkTop®, EDS file

Please see web address www.odva.org for further information and for downloading the EDS file or contact your Alfa Laval company.

3.1.4 ThinkTop® DeviceNet™ attribute list

Name	Path		R/W/CS	Raw data		Eng. Units Conv.		Bit maps / data								
	Class	Inst		dec.	hex.	Attributes	data type	len.	LSB	mult.	divisor	units	byte 1	byte 2	byte 3	byte 4
Release DNET 4.6																
Valve Value	4	1	3	-	-	R	BYTE	1	-	-	-	PLC_Image	-	-	-	-
Valve Command	4	3	3	-	-	R/W	BYTE	1	-	-	-	Solenoids 1,2&3	-	-	-	-
Alarm Status	4	4	3	-	-	R	BYTE	2	-	-	-	Alarm_Status	-	-	-	-
Alarm Mask	4	5	3	-	-	R/W	BYTE	2	-	-	-	Alarm_Mask	-	-	-	-
Extended Status #1	100	1	101	65	01	R	BYTE	3	-	-	-	Error_Byte	PLC_Image	LED_Image	-	-
Extended Status #2	100	1	102	66	02	R	BYTE	3	-	-	-	Alarm_Status	Travel_Status	Adjust_Status	-	-
Configuration	100	1	111	6F	0B	R	BYTE	2	-	-	-	M_Config	D_Config	-	-	-
Alarm #1 Setup	100	1	121	79	15	R/W	BYTE	2	0.524 sec.	-	-	End Condition	Time	-	-	-
Alarm #2 Setup	100	1	122	7A	16	R/W	BYTE	2	0.524 sec.	-	-	End Condition	Time	-	-	-
Alarm #3 Setup	100	1	123	7B	17	R/W	BYTE	2	0.524 sec.	-	-	End Condition	Time	-	-	-
Alarm #4 Setup	100	1	124	7C	18	R/W	BYTE	2	0.524 sec.	-	-	End Condition	Time	-	-	-
Alarm #5 Setup	100	1	125	7D	19	R/W	BYTE	2	0.524 sec.	-	-	End Condition	Time	-	-	-
Alarm #6 Setup	100	1	126	7E	1A	R/W	BYTE	2	0.524 sec.	-	-	End Condition	Time	-	-	-
Current Position	100	1	130	82	1E	R	UINT	2	0.01982 mm	991	50,000	mm	LSB	MSB	-	-
Time TOTAL	100	1	131	83	1F	R	UINT	2	2.38 hrs.	992	10,000	days	LSB	MSB	-	-
Time CLOSED	100	1	132	84	20	R	UINT	2	2.38 hrs.	992	10,000	days	LSB	MSB	-	-
Time OPEN	100	1	133	85	21	R	UINT	2	2.38 hrs.	992	10,000	days	LSB	MSB	-	-
Time to Maint.	100	1	134	86	22	R	UINT	2	2.38 hrs.	992	10,000	days	LSB	MSB	-	-
Last Stroke Time	100	1	135	87	23	R	UINT	2	0.131 sec.	131	10,000	sec.	LSB	MSB	-	-
Last Stroke Length	100	1	136	88	24	R	UINT	2	0.01982 mm	991	50,000	mm	LSB	MSB	-	-
LSB	mid byte	Coil Count #1	0	100	1	137	89	25	R	ULINT	4	counts	-	-	-	-
Coil Count #2	100	1	138	8A	26	R	ULINT	4	counts	-	-	counts	LSB	mid byte	MSB	0
Coil Count #3	100	1	139	8B	27	R	ULINT	4	counts	-	-	counts	LSB	mid byte	MSB	0

3.1.5 ThinkTop® DeviceNet_{TM} bit mappings

PLC_Image (feedbacks)	Travel in progress	Alarm timer expired	x	Maint.	SL2	SL1	OPEN	CLOSED
LED_Image	x	x	CLOSED	Maint.	Coil	Seat Lift	Setup	OPEN
Error_Byte	Multiple coil request	Timeout on last command	Button II failure	Button I failure	Tx/Rx failure	Bus Offline	Position Over Range	Check Sum Error
Solenoid 1, 2 & 3	x	x	x	x	Coil #3	Coil #2	Coil #1	x
Adjust_Status	x	x	CLOSED x	CLOSED x	OPEN Alarm	Alert	Alarm	x
Travel_Status	Travel In Progress	x	x	x	x	x	x	x
Timeout	Timer Running	on last command	Alarm #6 active	Alarm #5 active	Alarm #4 active	Alarm #3 active	Alarm #2 active	Alarm #1 active
Alarm_Status	Steady	x	x	x	SL2	SL1	OPEN	CLOSED
Alarm Setup (1..6) End condition: Time: LSB = 0.524 sec.	~ 67,1 s	~ 33,5 s	~ 16,8 s	~ 8,4 s	~ 4,2 s	~ 2,1 s	~ 1,0 s	~ 0,5 s
Alarm Mask	x	x	Coil #3 de-energize enabled	Coil #2 de-energize enabled	Coil #1 de-energize enabled	Coil #3 energize enabled	Coil #2 energize enabled	Coil #1 energize enabled
Travel Mask	x	x	Coil #3 de-energize disabled	Coil #2 de-energize disabled	Coil #1 de-energize disabled	Coil #3 energize disabled	Coil #2 energize disabled	Coil #1 energize disabled

3.1.6 ThinkTop® DeviceNet_{TM} Poll and COS command structures

Poll Request Message Format

		bit							
byte	7	6	5	4	3	2	1	0	
0	x	x	x	x	coil#3 energize	coil #2 energize	coil #1 energize	x	
1	x	x	alarm #6 enable coil #3 de-energize	alarm #5 enable coil #2 de-energize	alarm #4 enable coil #1 de-energize	alarm #3 enable coil #3 energize	alarm #2 enable coil #2 energize	alarm #1 enable coil #1 energize	
2	Write Attrib. Flag	Requested index for Class #100 attribute. Note: The index is 0-relative based on attribute ID #100							
3	Attribute Data Byte 0 - LSB								
4	Attribute Data Byte 1								
5	Attribute Data Byte 2								
6	Attribute Data Byte 3 - MSB								

Poll Response Message Format

		bit							
byte	7	6	5	4	3	2	1	0	
0	Travel in Progress	Timer Expired	x	MAINT. ERROR	Seat #2 Status	Seat #1 Status	OPEN Status	CLOSED Status	
1	Timer Running	Timer Expired	alarm #6 active	alarm #5 active	alarm #4 active	alarm #3 active	alarm #2 active	alarm #1 active	
2	Valid Data Flag	Requested index for Class #100 attribute. Note: The index is 0-relative based on attribute ID #100							
3	Attribute Data Byte 0 - LSB								
4	Attribute Data Byte 1								
5	Attribute Data Byte 2								
6	Attribute Data Byte 3 - MSB								

Note! The 2 bytes Poll command structure is the same as the 7 bytes command with only bytes 0,1 used.

COS command structure

COS Request Message

By definition the COS and Poll Request Messages are identical. For a device configured for a 7 bytes Poll, the corresponding COS request will be:

		bit							
byte		7	6	5	4	3	2	1	0
0		x	x	x	x	coil#3 energize	coil #2 energize	coil #1 energize	x
1		x	x	alarm #6 enable coil #3 de-energize	alarm #5 enable coil #2 de-energize	alarm #4 enable coil #1 de-energize	alarm #3 enable coil #3 energize	alarm #2 enable coil #2 energize	alarm #1 enable coil #1 energize
2	Write Attrib. Flag	Requested index for Class #100 attribute. Note: The index is 0-relative based on attribute ID #100							
3		Attribute Data Byte 0 - LSB							
4		Attribute Data Byte 1							
5		Attribute Data Byte 2							
6		Attribute Data Byte 3 - MSB							

For a device configured for a 2 bytes Poll, the corresponding COS request will be

		bit							
byte		7	6	5	4	3	2	1	0
0		x	x	x	x	Coil #3 energize	Coil #2 energize	Coil #1 energize	x
1		x	x	alarm #6 enable coil #3 de-energize	alarm #5 enable coil #2 de-energize	alarm #4 enable coil #1 de-energize	alarm #3 enable coil #3 energize	alarm #2 enable coil #2 energize	alarm #1 enable coil #1 energize

COS Response Message:

Only a 2 bytes message is supported and corresponds to the 2 bytes Poll response message format

		bit							
byte		7	6	5	4	3	2	1	0
0		Travel in Progress	Timer Expired	x	MAINT. ERROR	Seat #2 Status	Seat #1 Status	OPEN Status	CLOSED status
1		Timer Running	Timer Expired	alarm #6 active	alarm #5 active	alarm #4 active	alarm #3 active	alarm #2 active	alarm #1 active

Note! A 7 bytes COS response message is not supported.

COS Trigger:

The COS message is triggered by any change in the Valve Value (feedbacks) corresponding to byte-0 of the COS response message.

3.1.7 Typical power consumption

Test conditions: One ThinkTop® DeviceNet_{TM} 11-25 VDC connected to the network with 1 input (on) and:

No solenoids on	supply voltage 25 VDC	20 mA
1 solenoid active (PWM)	supply voltage 25 VDC	28 mA
2 solenoids active (PWM)	supply voltage 25 VDC	36 mA
3 solenoids active (PWM)	supply voltage 25 VDC	44 mA
No solenoids on	supply voltage 11 VDC	34 mA
1 solenoid active (PWM)	supply voltage 11 VDC	58 mA
2 solenoids active (PWM)	supply voltage 11 VDC	82 mA
3 solenoids active (PWM)	supply voltage 11 VDC	106 mA

Note: If the Aux. Outputs are used instead of the solenoids for activation of external devices, the consumption is depending on the load current (see "Aux. Outputs").

3.1.8 Materials

Plastic parts	Nylon PA12.
Steel parts	Stainless steel AISI 304 and 316.
Seals	FPM (air fittings), EPDM rubber for SMP-EC stem.

3.1.9 Micro environment demand specifications

Temperature		
Working:	-20°C to +85°C	IEC 68-2-1/2
Storage:	-40°C to +85°C	IEC 68-2-1/2
Temperature change:	-25°C to +70°C	IEC 68-2-14
Vibration	10-55 Hz, 0.7 mm 55-500 Hz, 10g 3 x 30 min, 1 octave/min	IEC 68-2-6
Drop test		IEC 68-2-32
Humidity		
Constant humidity:	+40°C, 21 days, 93% R.H.	IEC 68-2-3
Cyclic humidity:	+25°C/+55°C 12 cycles	IEC 68-2-30
(working)	93% R.H.	
Protection class	IP67	IEC 529
Input threshold Voltage/current:	Type 1 input requirements	EN 61131-2
EMC Directive	89/336/EEC	EN 50081-1, EN 50082-2
ODVA Approval	DeviceNet v. 2.0	Conformance Test version 14
UL Approval	8-30 VAC/VDC, Class 2 input, 45 mA max. output	UL508-E203255

Step 1

- **Always** read the technical specifications thoroughly (see chapter 3).
- **Always** have the *ThinkTop*® electrically connected by authorized personnel.
- **Never** install the *ThinkTop*® before valve or relay is in a safe position.

Step 2

1. Fit the air fittings on actuator if not mounted.
2. Fit the activator stem (magnet) and tighten **carefully** with a spanner.

NOTE!

The *ThinkTop*® for the SMP-EC valve has a longer activator stem going through the shell. Remember O-ring.

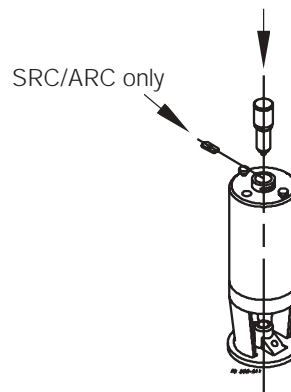
**Step 3**

1. Place the *ThinkTop*® on top of the actuator.
2. Make sure X-ring is mounted.

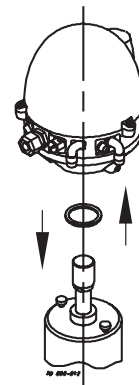
**Step 4**

1. Ensure that the unit is correctly mounted by pressing down on Top of the *ThinkTop*®.
2. Tighten the two Allen screws **carefully**.
3. Turn the actuator to have LEDs in a front view.

NOTE!

After a relevant period of time after installation (eg. two weeks) it is recommended to check that all connections are properly tightened.

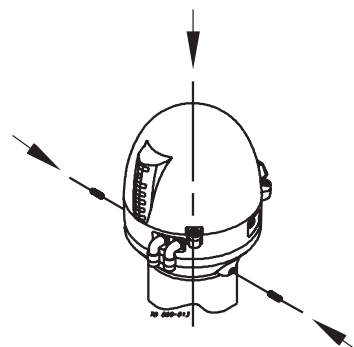

Step 5

Fit the $\varnothing 6$ mm (1/4") air tubes to *ThinkTop*[®] (see drawing "Air connections" later in this chapter).

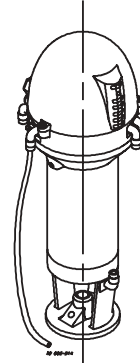

Step 6

Fit the air tubes to the actuator (see drawing "Air connections" later in this chapter).

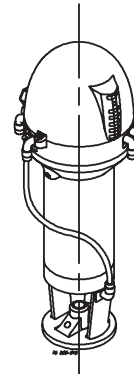

Step 7

Untighten the three screws and pull off cover of *ThinkTop*[®].

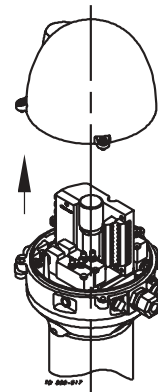

Step 8

1. Install cable (if not present) through the cable gland.
2. Connect the *ThinkTop*[®] electrically (see section 4.4 "Electrical connection, internal").

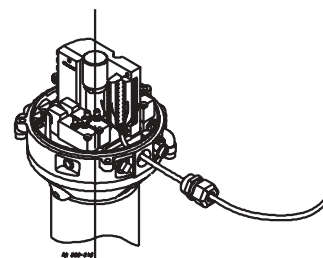

Step 9

Make sure the cable gland is completely tightened.

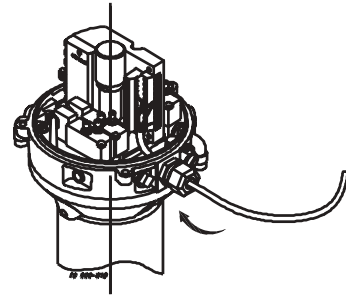
**Step 10**

Set up the *ThinkTop*® (see chapter 5).

NOTE!

The unit can be set up with the cover installed by using the IR keypad. To energize the valve, use a separate air tube or be in radio contact with the control room.

Step 1

1. Remove the cover by loosening the three cross recess screws.
2. Separate the adapter from the base by loosening the three recess screws on top of the base.

Installation on air actuators:

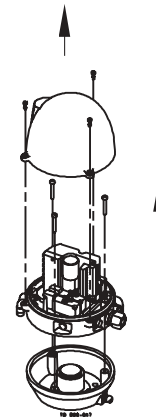

Step 2

1. Fit air fittings on actuator.
2. Position packing retainer in recess on actuator top.
3. Fit counter nut and indicator (magnet) on actuator rod. Engage approx. 1/4" thread. Tighten counter nut and indicator with two wrenches.

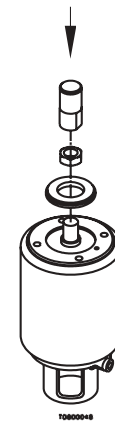

Step 3

1. Place the two O-rings in the grooves in the bottom of the adapter. Then place the adapter on the actuator top. The small O-ring must be positioned over the air hole on the actuator.
2. Fasten the adapter with the four 5/16" Allen screws.



Step 4

Mount the base on the adapter in the position needed (can be rotated 120° in both directions). Note that one of the screw towers on the adapter has a guide recess (see ★ on

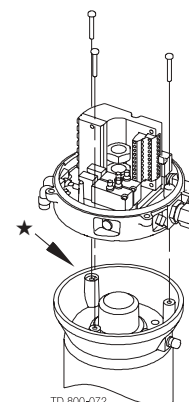

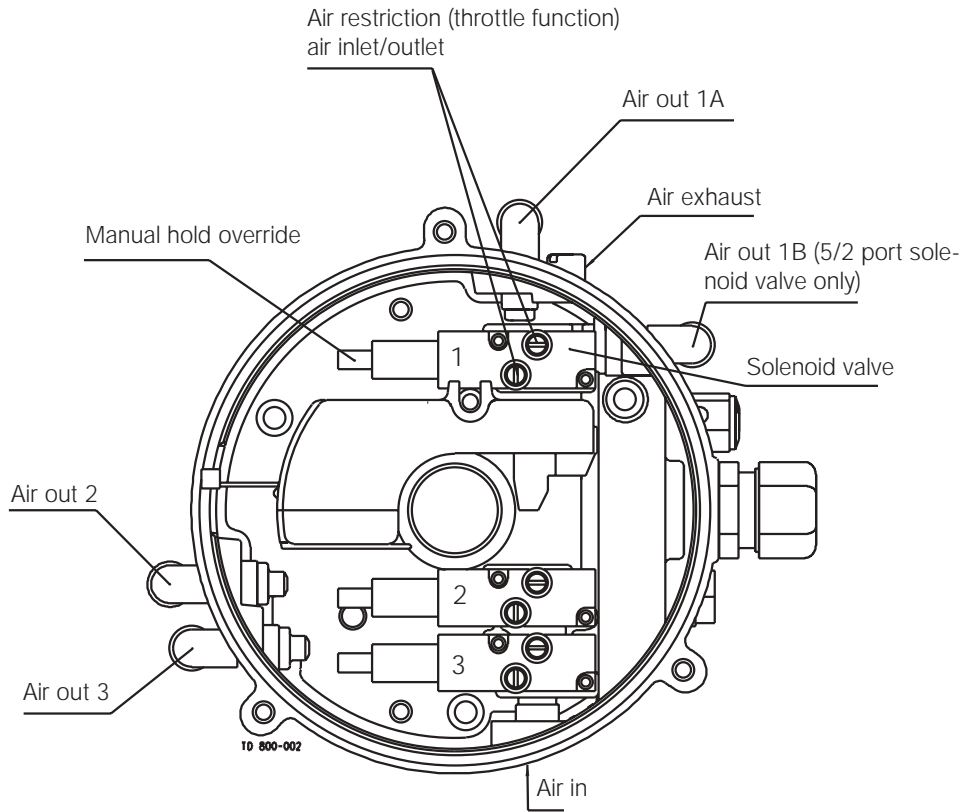

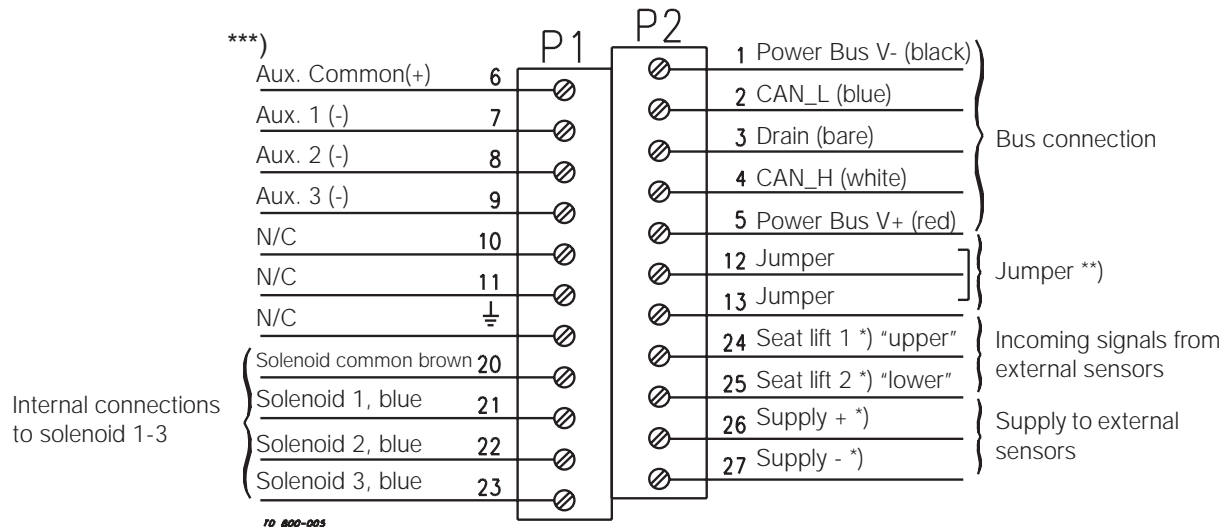

*) **Note!**
 Terminals 24, 25, 26 and 27 can be used for external seatlift sensors as well as for any digital input. They are associated with feedback signal 3 (seatlift 1) and 4 (seatlift 2). External sensor must always be a 8-30 VDC PNP 3 wire sensor. Connect (-) common on terminal 27, and (+) common on terminal 26.

***) **Note!**
 Jumper present = 7 I/O bytes; Rx size 7 and Tx size 7 - standard.
 Changing from 7 bytes to 2 bytes: Remove jumper (#12 and #13). A power recycle is necessary when changing byte sizes.

***) **Note!**
 Three aux. outputs can be used for external devices. The drivers are always NPN outputs and PWM mode is not possible. The number of aux. outputs for activation of external devices can be 0-3. Clarification: All 3 outputs can be activated at the same time but if solenoid 1 is in use, aux. 1 can not be used! If solenoid 1 and 2 are in use, aux. 1 and 2 can not be used! If solenoid 1, 2 and 3 are in use, no aux. can be used! A mix of solenoid and aux. outputs is possible.

Output: NPN (sinking).
 Output voltage: 24 VDC ± 15%. Network power connection! User must ensure 24 VDC on the network (at the top) when these outputs are used.
 Load current: Max 75 mA.
 As these outputs drive constant current, using several nodes in this mode will reduce the number of nodes supported by a typical 8A network supply. The user must ensure that total network current consumption is less than the supply rating.

- Notes:**
- O - Scroll across, no change
 - - Notes Requires Key Function
 - - Notes Automatic Progress as Indicated

- General:**
1. Flashing IND means no value set.
Steady IND means value set as shown.
 2. Default is: Step 2, Type 0 (+/- 5 mm)
Step 3-8 disabled
 3. Lamp Status Shown in []

ThinkTop® Visual Indications

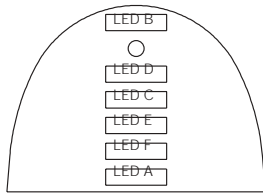

LED Indications

- *Open valve* (Yellow)
- IR-Receiver
- *Setup/Internal fault* (Red)
- *Seat-lift 1/2* (Yellow)
- *Solenoid valves* (Green)
- *Maintenance* (Orange)
- *Closed valve* (Yellow)

4. [D] IND active during set-up.
 - Flashing in step 1,
 - Steady in all other steps.
 or during operations, error condition
 - Steady showing hardware fault
 - Flashing showing software fault
5. Timeout: A 60 second time-out is started as soon as any button(s) are released. If no button is pressed during the time-out time, go to normal condition (cancel & exit).
6. SRC/ARC valves: Self-adjust (step 7) must be activated. If you choose NOT to use the self-adjustment programme, Alfa Laval recommends to use the valve type 4 (step 2), instead

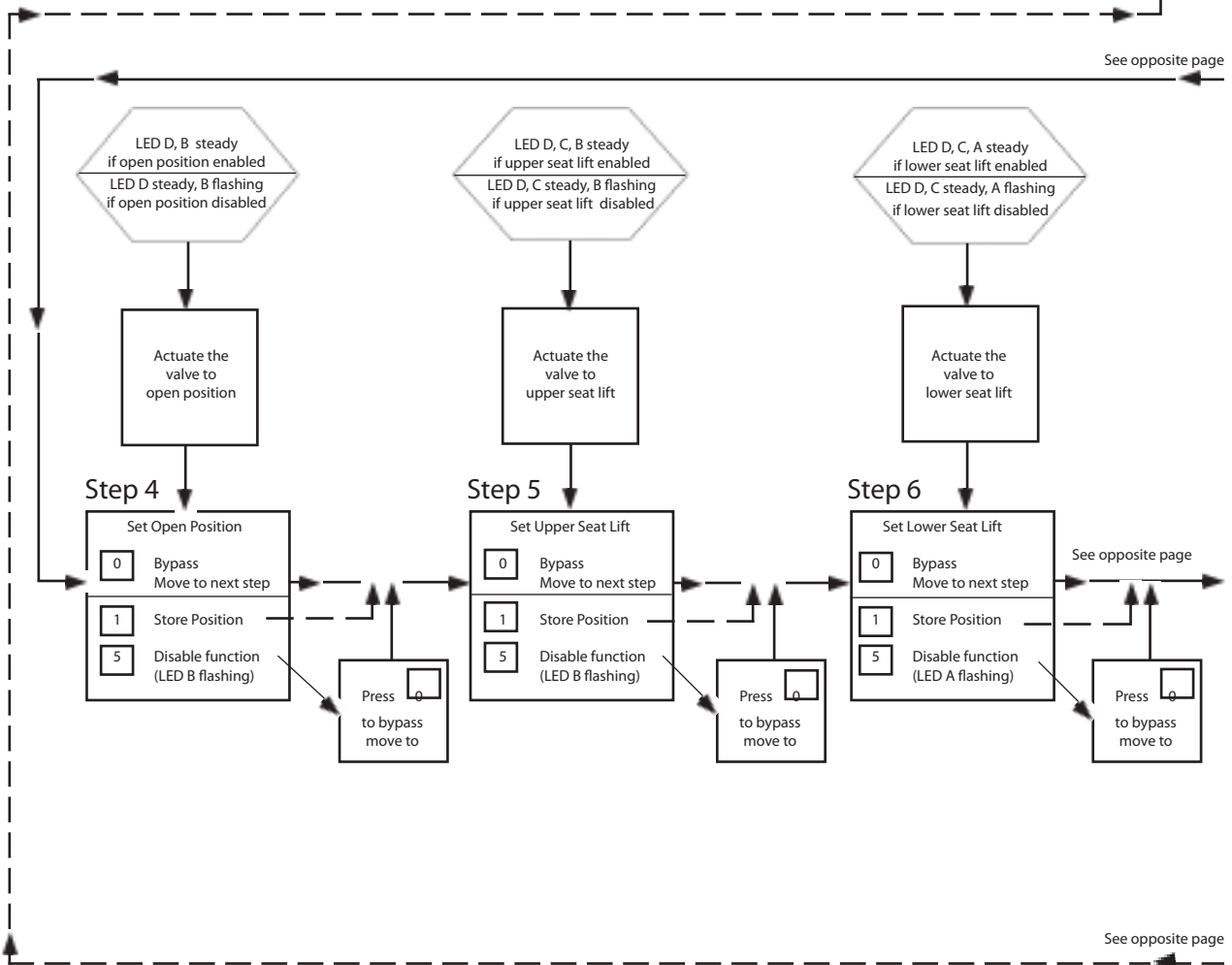
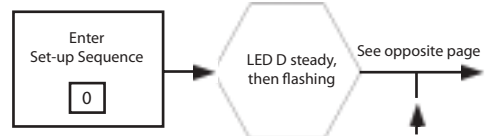

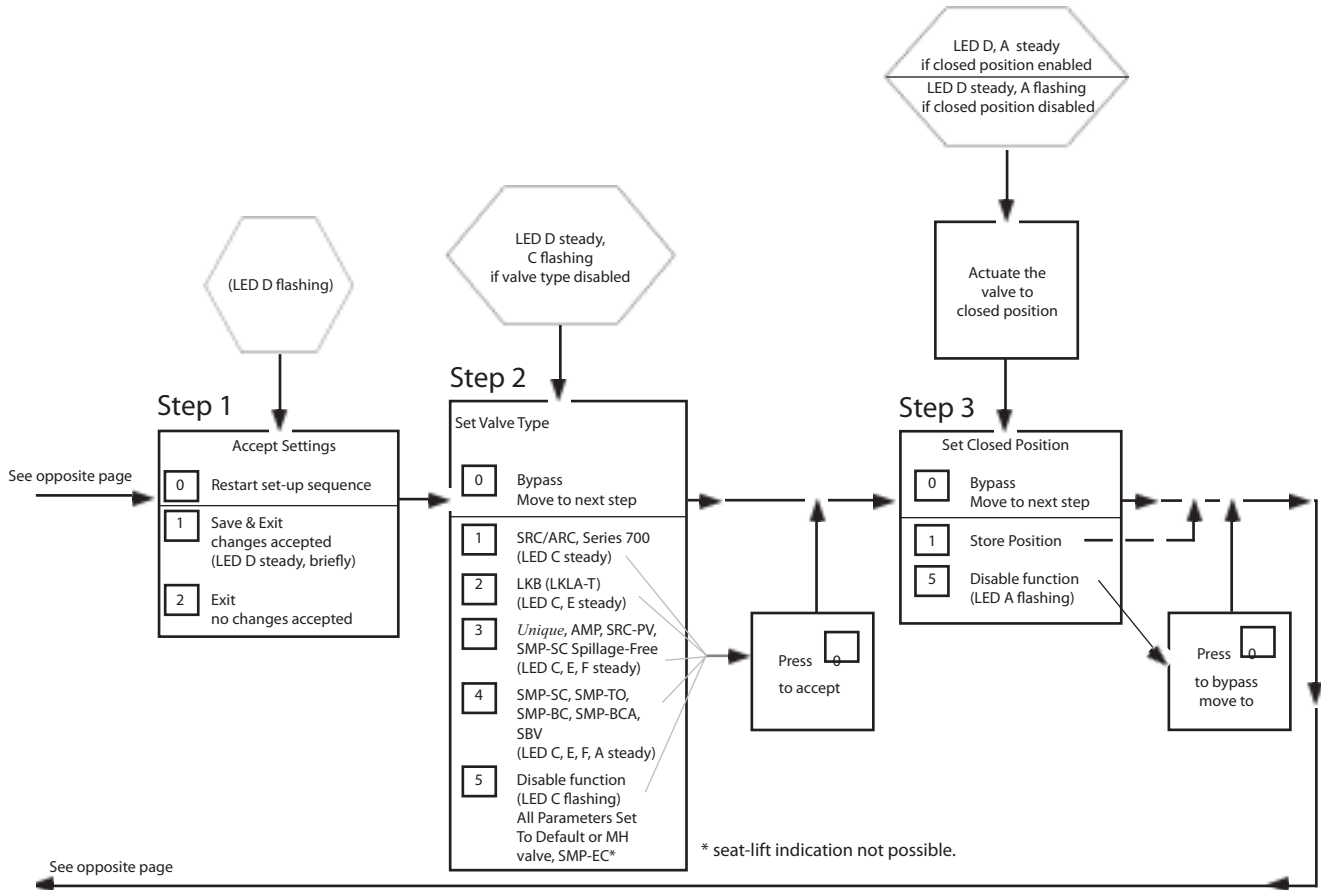

Note! Remote distance keypad = ThinkTop® 0-300 mm.

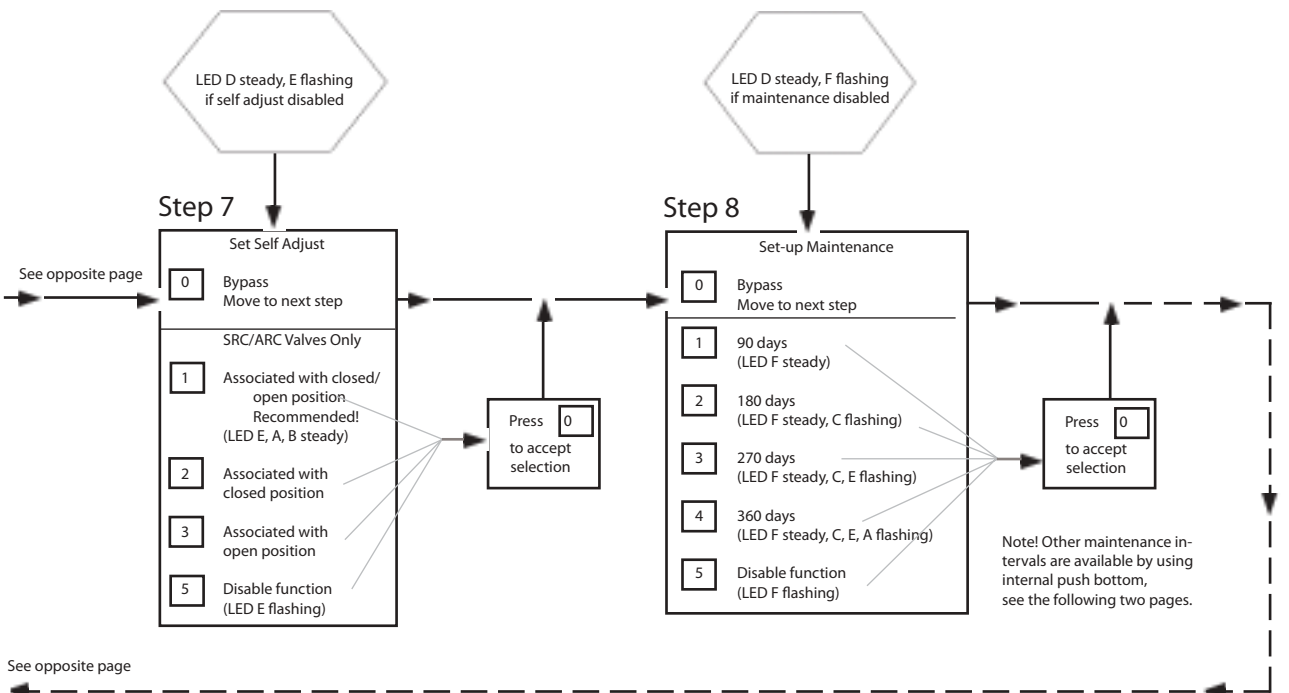

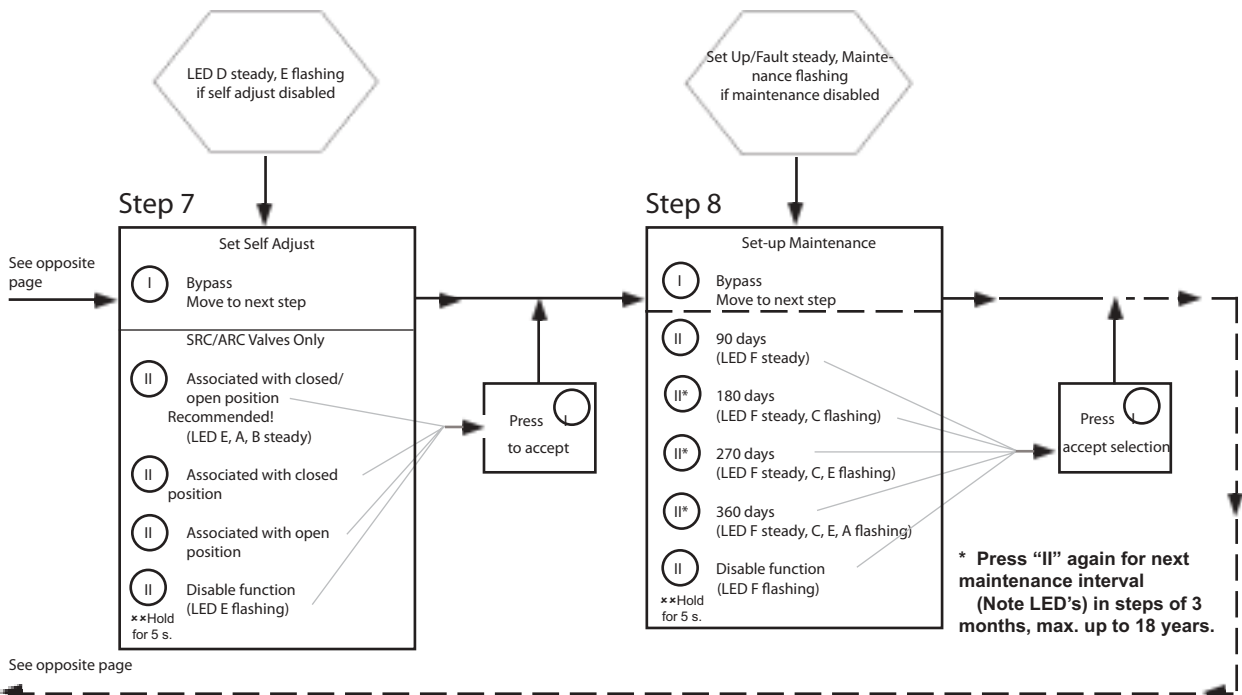
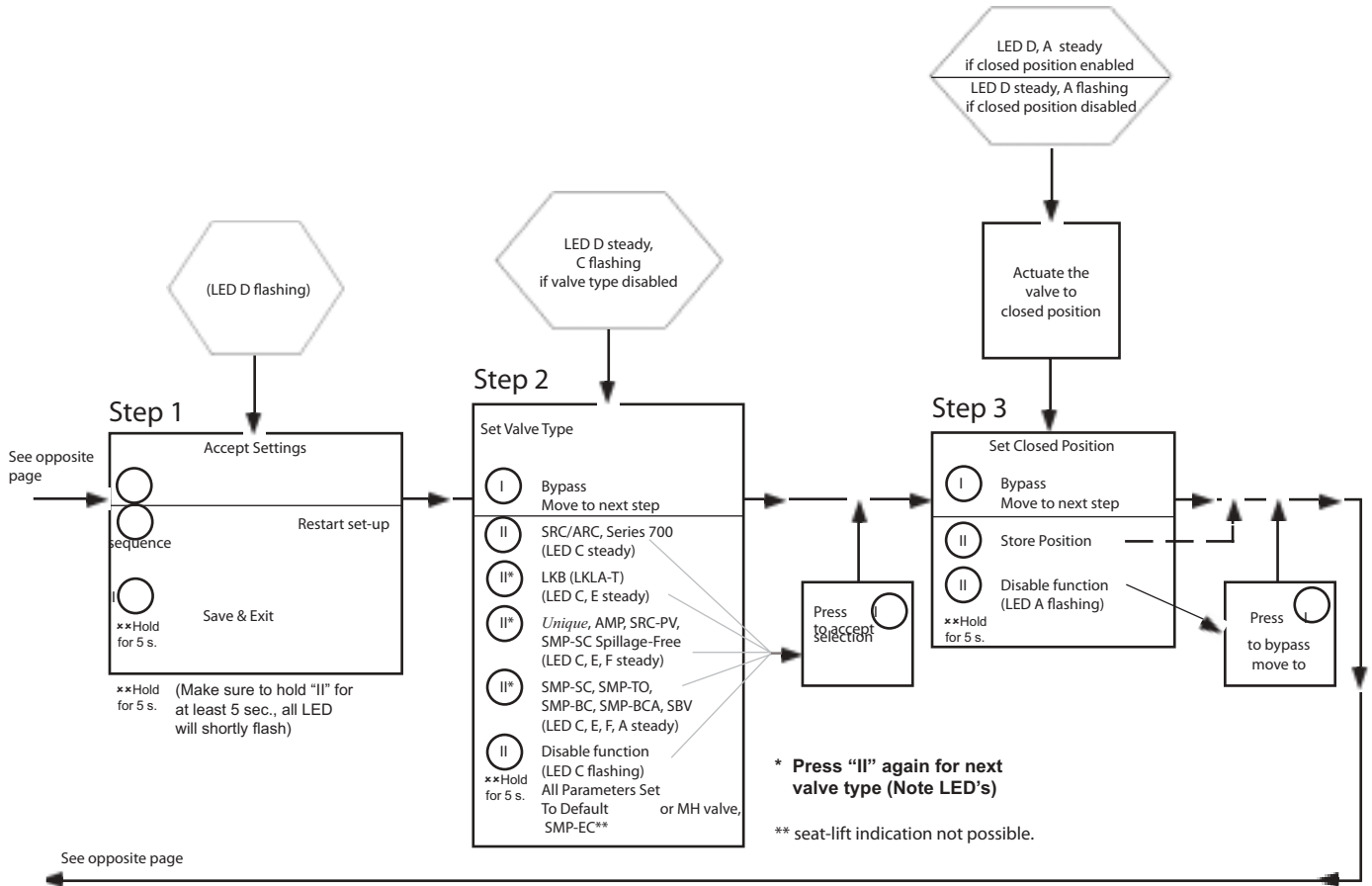

Below is stated the meaning of the LEDs' indications for fault finding in connection with the operation of the *ThinkTop*[®].

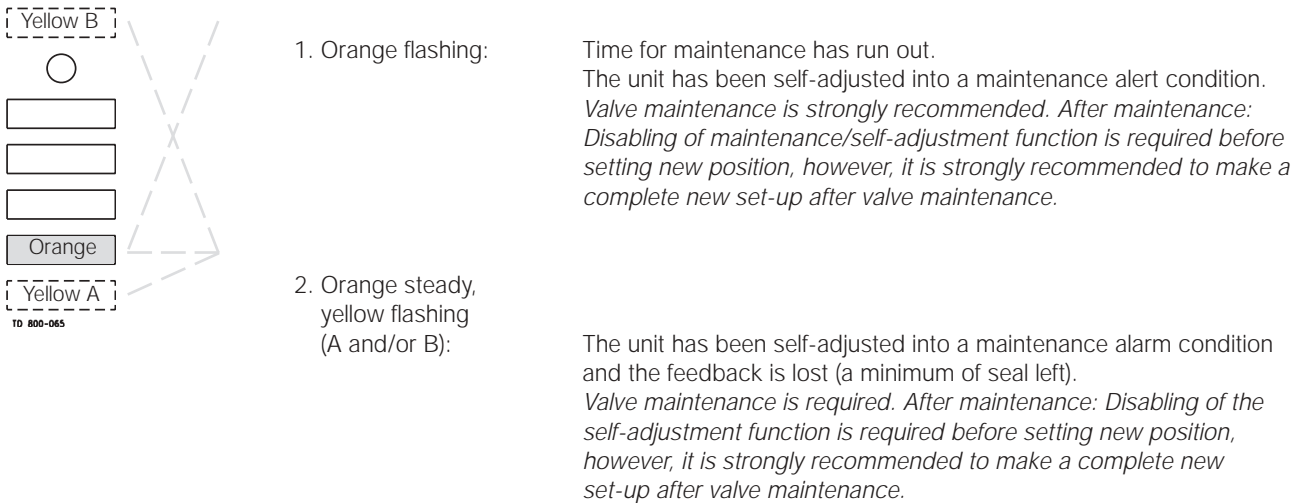
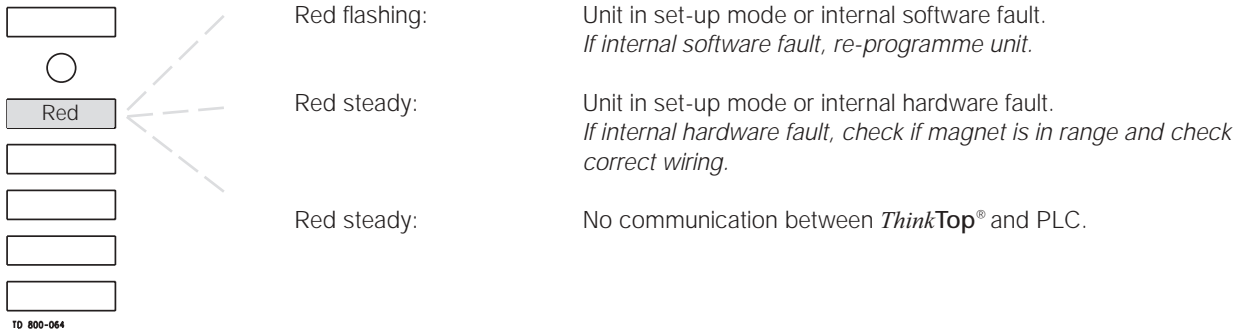

NOTE!

The maintenance indicator lighting up, and an open or closed light flashing.....

= Note the following:

- Self-adjustment programme is only valid for **SRC/ARC** valves, **do not use the programme for other valve types**.
- Use tolerance/valve type 1.
- In conjunction with valve type change-over; 21, 22, 31 and 32, the open position must be defined as the upper sensor position (when the magnet is in the highest position).
- A loose top, magnet holder or sensor system can also generate the alert/alarm condition.
- Removing a *ThinkTop*[®] with self-adjust activated, will immediately generate an alarm condition! If the *ThinkTop*[®] has to be removed, not because of a valve maintenance issue, but for some other reasons, and you want to store the already adjusted data - disable the self-adjust function before removing the *ThinkTop*[®] and enable it again once the *ThinkTop*[®] is back on the actuator.
- After valve maintenance a disabling of the self-adjustment function is required before setting a new position, however, it is strongly recommended to make a complete new set-up (disable all functions in step 2 valve type - and make a complete new set-up).

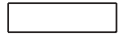
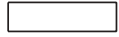

TD 800-064

Yellow steady:

Position A (closed valve).

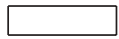
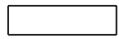

TD 800-064

Yellow steady:

Position B (open valve).

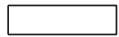
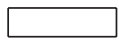
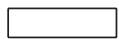

TD 800-064

Yellow steady:

Position C (Seat lift 1-2 or external sensors).

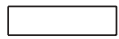
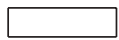
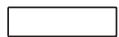

TD 800-064

Green steady:

Solenoid valves activated.

Note! During set-up LED lights have different functions.

Study the instructions carefully.
Handle scrap correctly.
Always keep spare X-rings in stock.

Step 1

1. Remove the *ThinkTop*® from the actuator.
2. Pull out X-ring (19) and replace it.

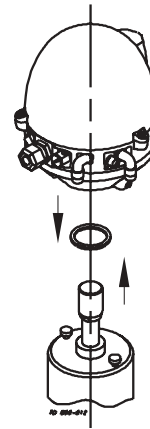
**Step 2**

1. Untighten the three screws.
2. Pull off the *ThinkTop*® cover.
3. Remove X-ring (9).

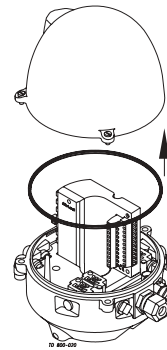
**Step 3**

1. Untighten screws.
2. Remove solenoid valves (up to 3) and replace them with new ones.

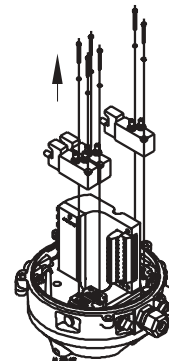
**Step 4**

1. To dismantle the adapter (the lower part of the *ThinkTop*®) from base (the middle part), unscrew the three screws.
2. Turn the lower part a little clockwise and pull.
3. Replace adapter if necessary.
4. Remove X-ring (16).

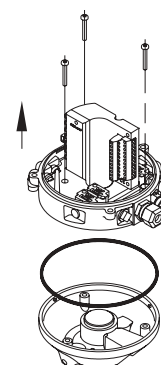

Note:
Turn banjo
connection!

*Study the instructions carefully.
Handle scrap correctly.
Always keep spare X-rings in stock.*

Step 5

To remove the sensor unit untighten screw and pull out the sensor unit.

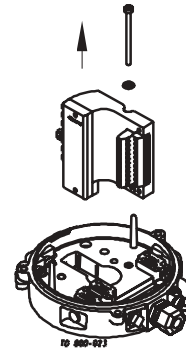

Study the instructions carefully.
 Handle scrap correctly.
 Always keep spare X-rings in stock.

Step 1

Place sensor unit in base and tighten screw (torque: 1 Nm).

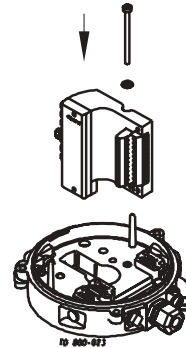

Step 2

1. Assemble base with adapter by turning adapter a little anticlockwise and tighten the three screws (1.9 Nm).
2. Replace X-ring (16).

CAUTION!

Do **NOT** twist the X-ring in the groove!

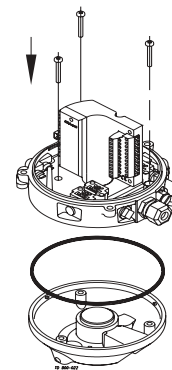
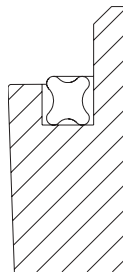

Note:
Turn banjo
connection!

Step 3

1. Replace solenoid valves (up to three) with new ones.
2. Tighten screws (0.2 Nm).

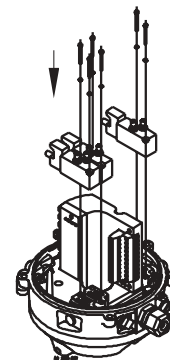

Step 4

1. Replace cover of *ThinkTop*® and tighten the three screws (0.6 Nm).
2. Replace X-ring (9).

CAUTION!

Do **NOT** twist the X-ring in the groove!

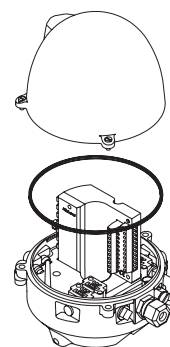
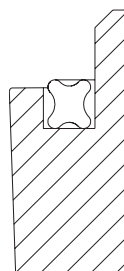

*Study the instructions carefully.
Handle scrap correctly.
Always keep spare X-rings in stock.*

Step 5

1. Replace X-ring (19).
2. Mount the *ThinkTop*® on actuator.

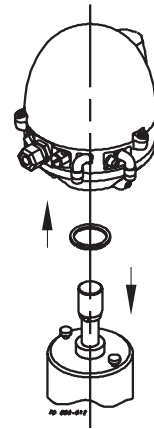

*Study the instructions carefully.
Handle scrap correctly.
Always keep spare X-rings in stock.*

Step 1

1. Remove the cover by loosening the three cross recess screws.
2. Separate the adapter from the base by loosening the three recess screws on top of the base.

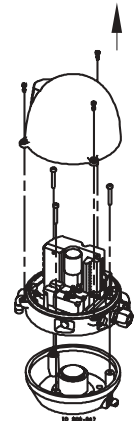
Installation on air actuators:**Step 2**

1. Fit air fittings on actuator.
2. Position packing retainer in recess on actuator top.
3. Fit counter nut and indicator (magnet) on actuator rod. Engage approx. 1/4" thread. Tighten counter nut and indicator with two wrenches.

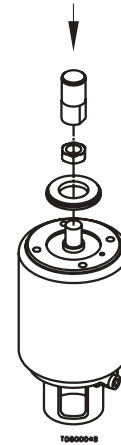
**Step 3**

1. Place the two O-rings in the grooves in the bottom of the adapter. Then place the adapter on the actuator top. The small O-ring must be positioned over the air hole on the actuator.
2. Fasten the adapter with the four 5/16" Allen screws.

**Step 4**

- Mount the base on the adapter in the position needed (can be rotated 120° in both directions). Note that one of the screw towers on the adapter has a guide recess (see ★ on drawing).
- Remove x-rings (9) and (16).
- Replace with new ones.

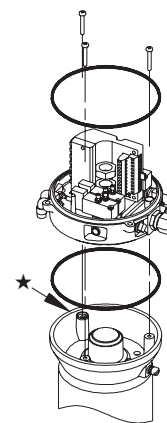

The drawing and the parts list include all items.

Parts List

Pos.	Denomination
1a	Shell
1b	Shell
2	O-ring
3	Screw
4	Washer
5	Sensor unit
6	Solenoid valve
7	PT screw
8	Base
9	Special X-ring
10	Air fittings
11	Blow-off valve
12	Thread plug, PG7
13	Cable gland, PG11 4-10 mm
14	Pressure control valve
15	Adapter
16	Special X-ring
17	O-ring
18	Allen screw
19	Special X-ring
20a	Indication pin
20b	Indication pin
21	O-ring
24	Air fitting incl. O-ring

Spare Parts

Denomination	Item number
Sensor unit DeviceNet™ 11-25 VDC.....	9612-5627-04
Solenoid valve 3/2, 8 VDC	9611-99-3748
Solenoid valve 5/2, 8 VDC	9611-99-3749
Air fitting incl. O-ring, Ø6 mm.....	9611-99-3404
Air fitting incl. O-ring, 1/4".....	9611-99-3434

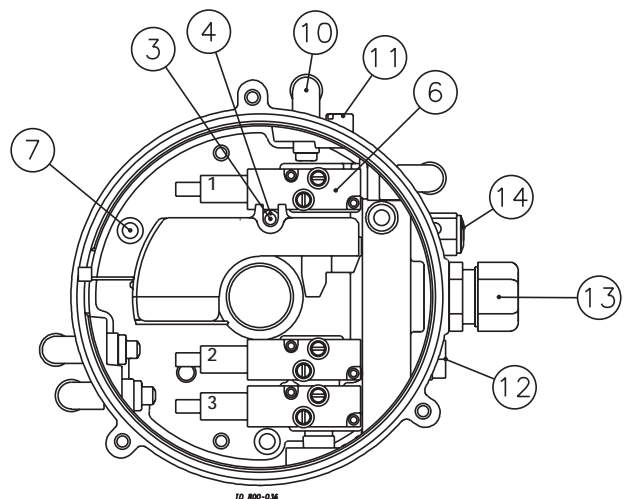
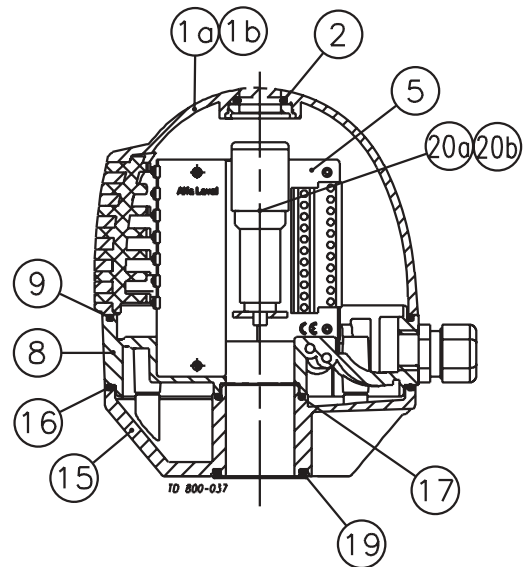
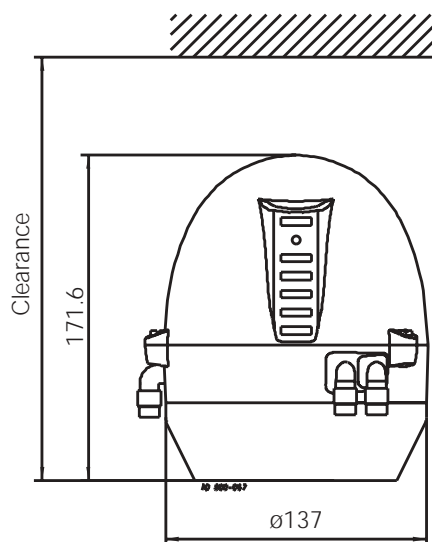

Note! This is the basic design.

The clearance should be approximately:

- ø 225 x 250 (SRC NC, SMP-SC/-BC/-TO, Unique, Koltek MH, SBV, AMP)
- ø 225 x 320 (SRC NO)
- ø 225 x 300 (LKB (LKLA-T))

This page shows an exploded drawing of the ThinkTop®.

The drawing includes all items of the top unit.

Exploded Drawing

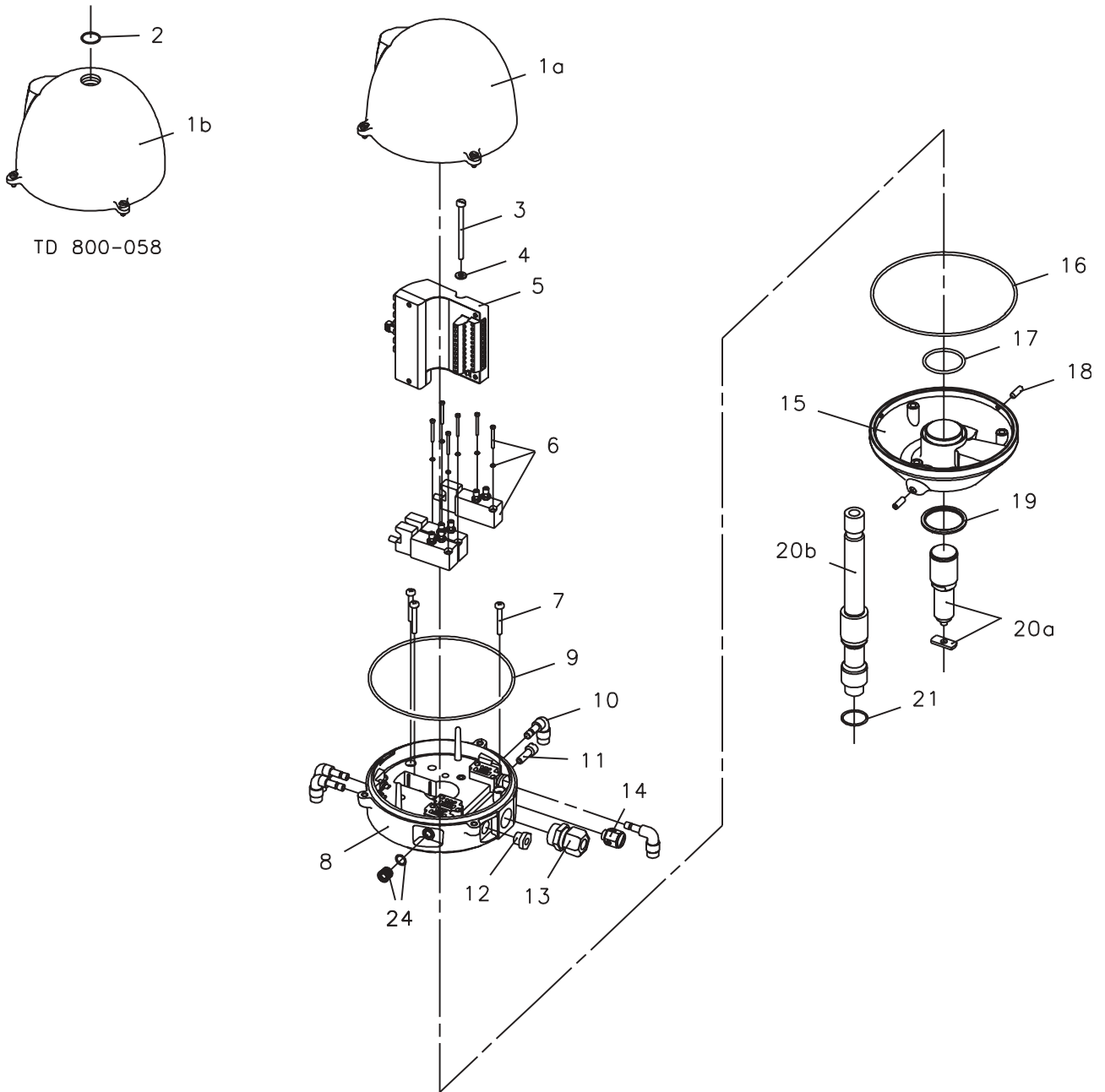

The drawing and the parts list include all items.

Parts List

Pos.	Denomination
1	Shell
3	Screw
4	Washer
5	Sensor unit
6	Solenoid valve
7	PT screw
8	Base
9	Special X-ring
10	Air fittings
11	Blow-off valve
12	Thread plug, PG7
13	Cable gland, PG11 4-10 mm
14	Pressure control valve
15	Adapter
16	Special X-ring
17	O-ring
18	Screw
19	Retainer
20	O-ring
21	O-ring
22	Indicator pin
23	Nut
26	Air fitting incl. O-ring

Spare Parts

Denomination	1/4" Air connec.
Sensor unit DeviceNet™ 11-25 VDC.....	9612-5627-04
Solenoid valve 3/2, 8 VDC	9611-99-3748
Solenoid valve 5/2, 8 VDC	9611-99-3749
Air fitting incl. O-ring, 1/4"	9611-99-3434

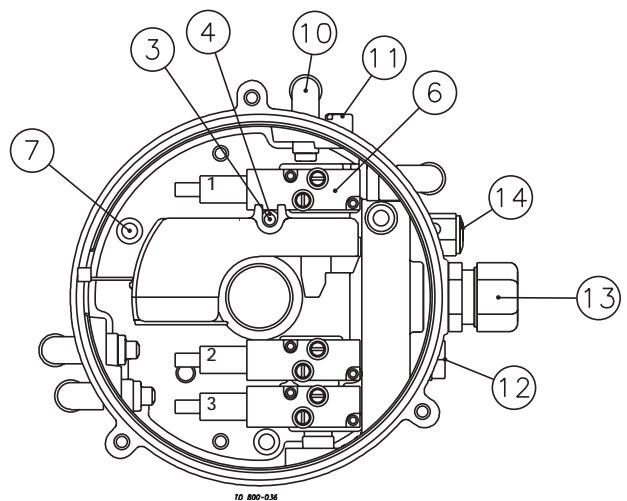
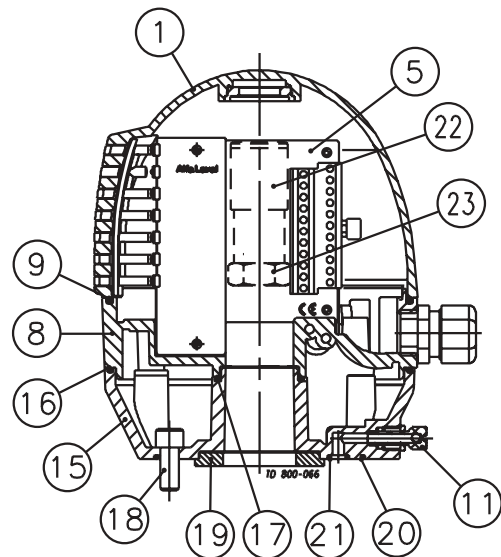
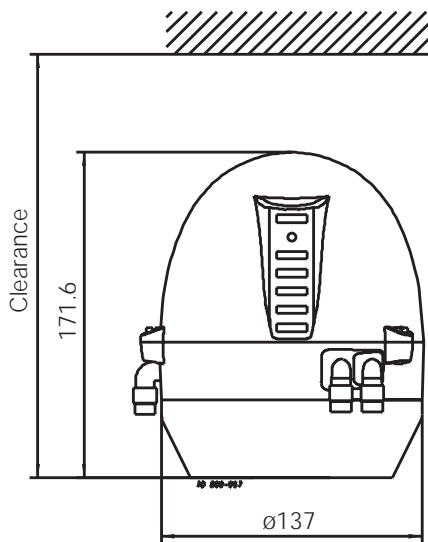

Note! This is the basic design.

The clearance should be approximately:

- ø 225 x 250 (SRC NC, SMP-SC/-BC/-TO, Unique, Koltek MH, SBV, AMP)
- ø 225 x 320 (SRC NO)
- ø 225 x 300 (LKB (LKLA-T))

This page shows an exploded drawing of the ThinkTop®.

The drawing includes all items of the top unit.

Exploded Drawing

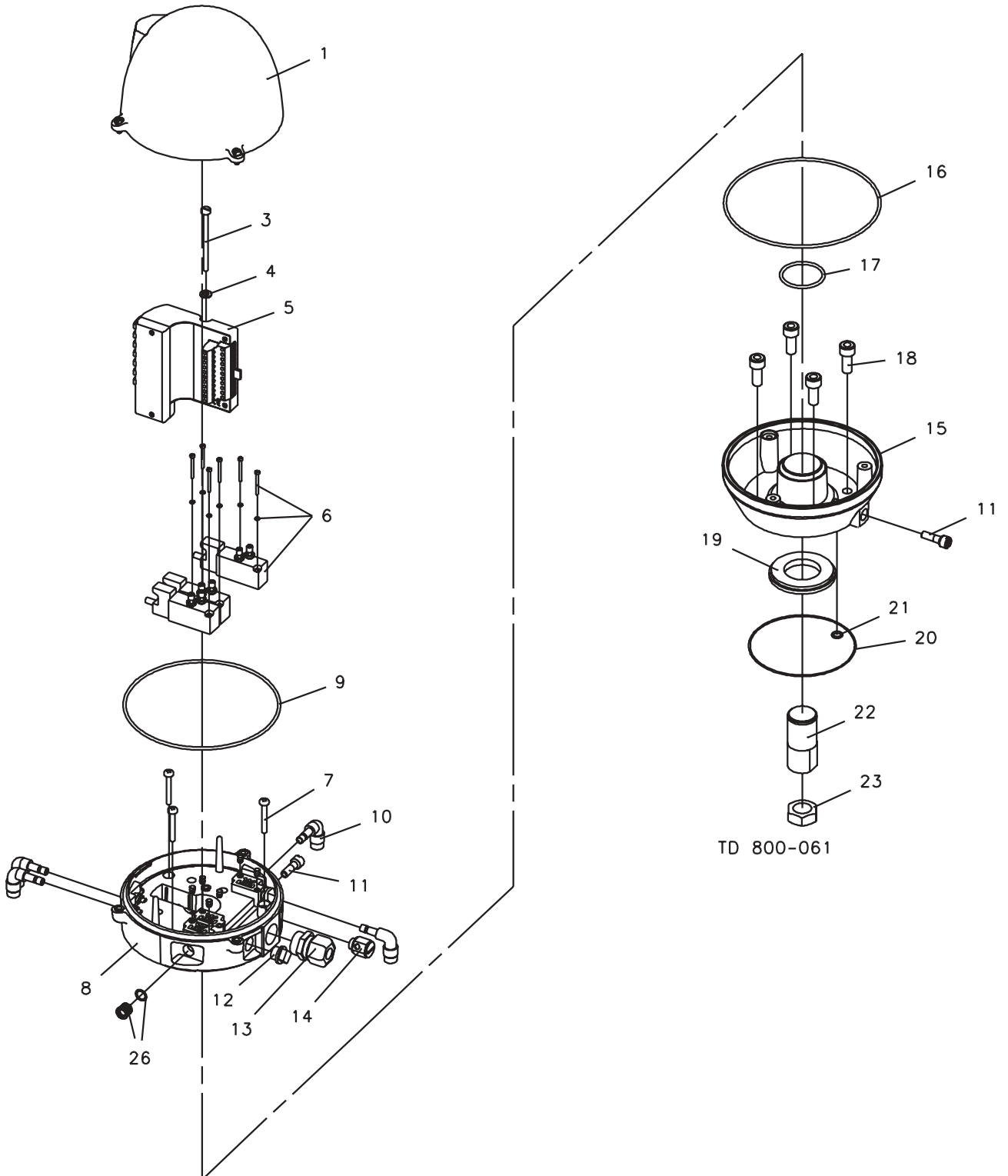

How to contact Alfa Laval

Contact details for all countries are continually updated on our website.

Please visit www.alfalaval.com to access the information direct.