

A System for More Control and Versatility

Green Top Control and Indication Unit

Application

To accommodate the trend towards custom control needs, an optional control housing module is available for our butterfly valves and our 700 series valves in place of the standard visual valve position indicator.

Working Principle

The top is fitted on the valve actuator. An extension attached to the actuator piston moves up and down with the valve movement. This movement is then seen by the position sensors and a digital signal is sent back to the PLC control system.

Standard Design

The control module is designed for fast assembly and disassembly. It can be mounted at either end of the actuator to accommodate normally open or normally closed valves - with no internal modifications to the actuator assembly needed. It's compatible with either long-stroke or short-stroke actuators.

Constructed from durable, glass-reinforced Nylon 12, the control housing is manufactured to stand up to the most punishing environments. It meets the NEMA 4 rating against leakage. Specially molded gaskets guard against leakage and breakdown, so the housing can be installed in any position.

Additional application versatility can be achieved by specifying a solenoid in the control housing. This transforms the valve into a solenoid operated air valve with integral flow control. The module will then provide valve position feedback through your choice of mechanical switches or proximity switches.



Options



Housing is designed to accommodate a variety of switch options, including proximity or mechanical switches.

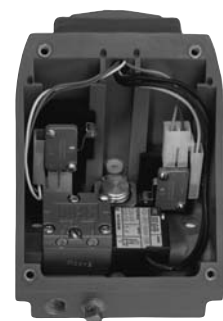

Control Top can also be fitted with a 3-way/4-way solenoid with integral flow control.

Enclosure Rating

NEMA Type 4 - Enclosures are intended for use indoors or outdoors to protect the enclosed equipment against splashing water, seepage of water, falling or hose-directed water, and severe external condensation.

3.6

Mechanical Switch

SPDT

3 amps/125 or 250 VAC*

1/2 amp, 125 VDC; 1/4 amp, 250 VDC

Solenoid Operating Data

Pressure Range: 0 to 120 psig**

Fluids: Air or Inert Gas

Lubrication: Not Required

Electrical:

AC 110/60 - .5.4 Watts

AC 24/60 - 7.4 Watts

DC 24 - 4.2 Watts

Coil:

General purpose class A, continuous duty.

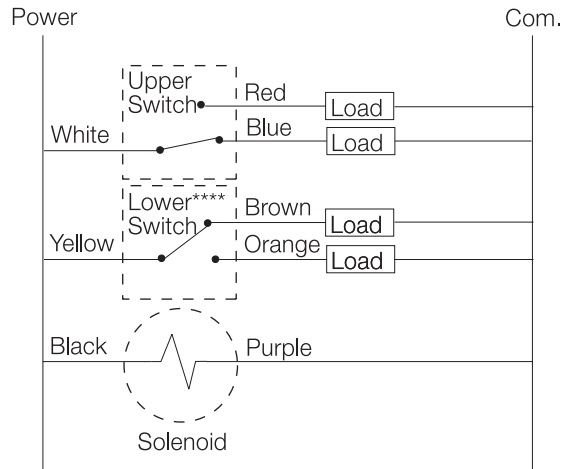

Proximity Sensor***

2 wire, Normally Open

20-140 VAC, 50-60 Hz

10-140 VDC

200mA Load Current Max..8mA Leakage Current

Solenoid Operating Data

Pressure Range: 0 to 120 psig*

Fluids: Air or Inert Gas

Lubrication: Not Required

Electrical:

AC 120/60 - 5.4 Watts

AC 24/60 - 7.4 Watts

DC 24 - 4.2 Watts

Coil:

General purpose class A, continuous duty.

Color code represents the cable assembly wires

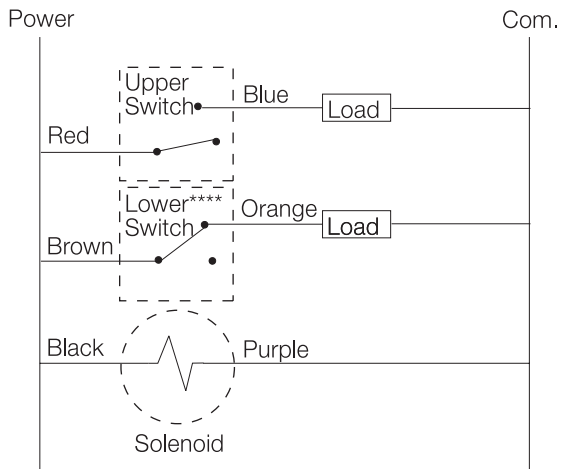

* 3 amps/125Vac max. due to 20 gauge wiring.

** Supply pressure to any valve/actuator should not exceed 80psig.

*** Other sensor types available, contact Alfa Laval for details.

**** Normally open switch held closed.

Dimensions

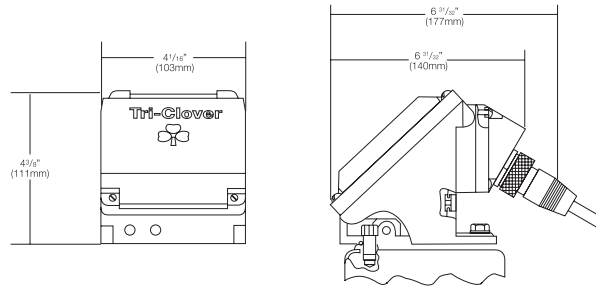

3.6

Make sure you understand the 761 model code

761	-	10M	-	29L	-	2	-	316L	-	04	-	4
1		2		3		4		5		6		7

There are seven different sections to a standard part number. The part number sections will identify the valve and control top options and function. Each valve assembly has its factory original serial and part number printed on an identification label located on the actuator.

Valve Type	1	741, 761, 762, 771
Body Style/Port Configuration	2	Refer to Valve Service Manual
Actuator Type	3	Refer to Valve Service Manual
Size	4	1" through 4"
Material	5	316L
Switch / Solenoid Option	6	See Chart Below
Setup Option	7	See Chart Below

6
The SWITCH / SOLENOID chart identifies what type of electrical components are to be utilized in the control top module. There are three standard solenoid voltages and three options for switch/sensors to select from. For any combination there is an option code ranging from 02 through 45.

		No Solenoid	24VDC Solenoid	110 VAC Solenoid	24 VAC Solenoid
Mechanical [VAC/VDC]	Quantity 1	02	14	16	39
	Quantity 2	04	18	20	40
Proximity [VAC/VDC]	Quantity 1	10	30	32	43
	Quantity 2	12	34	36	44
No Switches/Solenoid Only		-	37	38	45

7
The SET-UP NUMBER SELECTION charts define how the control top module is configured. There are up to seven different ways that it can be setup, but depending upon valve type and body style the operation can differ. Knowledge of the complete valve model is required to choose between the two charts. **Chart A applies to Shut Off or Divert valves and Chart B applies to Reverse Acting and Kettle & Elbow tank outlet valves.**

Chart A

Actuator	Description	Set-Up #
19, 29, 39	No Solenoid, normally open or normally closed valve	1
19	Normally open valve closes when solenoid is deenergized	2
29	Normally closed valve opens when solenoid is deenergized	3
29	Normally closed valve opens when solenoid is energized	4
19	Normally open valve closes when solenoid is energized	5
29, 39	Air both ways, opens when solenoid is energized	6

Chart B

Actuator	Description	Set-Up #
19, 29, 39	No Solenoid, normally open or normally closed valve	1
19	Normally closed valve opens when solenoid is deenergized	2
19	Normally open valve closes when solenoid is deenergized	3
19	Normally open valve closes when solenoid is energized	4
29	Normally closed valve opens when solenoid is energized	5
29, 39	Air both ways, opens when solenoid is energized	6

Make sure you understand the LKB53 model code

LKB53A	-	6300T	-	3	-	E	-	316L	-	04	-	2
1	2	3		4		5		6		7		8

There are seven different sections to a standard part number. The part number sections will identify the valve and control top options and function. Each valve assembly has its factory part number printed on an identification label located on the actuator.

End Connection	1	LKB53A (Tri-Clamp®) or LKB53W (Ti-Weld)
Finish	2	Sanitary (-), Industrial (I)
Actuator Type	3	Refer to Valve Price Book
Size	4	1" through 4"
Seat Material	5	EDPM (E), Silicone (X), Fluoroelastamer (FY)
Material	6	304 (S) or 316L (316L)
Switch / Solenoid Option	7	See Chart Below
Setup Option	8	See Chart Below

7

The **SWITCH / SOLENOID chart** identifies what type of electrical components are to be utilized in the control top module. There are three standard solenoid voltages and three options for switch/sensors to select from. For any combination there is an option code ranging from 02 through 45.

		No Solenoid	24VDC Solenoid	110 VAC Solenoid	24 VAC Solenoid
Mechanical [VAC/VDC]	Quantity 1	02	14	16	39
	Quantity 2	04	18	20	40
Proximity [VAC/VDC]	Quantity 1	10	30	32	43
	Quantity 2	12	34	36	44
No Switches /Solenoid Only		-	37	38	45

8

The **SET-UP NUMBER SELECTION** defines how the control top module is configured. There are three different ways that it can be setup.

Description	Set-Up #
No Solenoid, normally open or normally closed valve	1
Normally open valve closes when solenoid is deenergized	2
Normally closed valve opens when solenoid is deenergized	2
Normally open valve closes when solenoid is energized	5
Normally closed valve opens when solenoid is energized	6

*Note: Butterfly valves regardless of position (normally open or normally closed) operate with the same control set-up.

Options

There are several options for various cable connections and proximity switches. Please contact Alfa Laval for information.

Ordering

The Control/Indication Top can be ordered separately for field installation. Use the prefix 74-100-X-X. Simply use the above charts to fill in the option:

Example: (2) mechanical switch/no solenoid - 74-100-04-1