

Leave Surveillance to the Top

ThinkTop® Digital 8-30 VDC PNP/NPN

Application

The ThinkTop® is designed to ensure optimum valve control in conjunction with Alfa Laval sanitary valves and it is compatible with all major PLC systems (Programmable Logic Controller with PNP/NPN interface). It is for use in food, dairy and brewery installations and in biopharmaceutical applications and can be used indoors as well as outdoors.

Working Principle

The ThinkTop® is a control head including position indication and solenoid valves. It is used to control and supervise sanitary pneumatic valves. It is mounted on top of the valve. It receives signals from a PLC to control the valve and it sends feedback signals to the PLC to indicate when the valve is in a certain position.

To configure the sensor unit to the specific valve and to the application, the user sets up the ThinkTop® either by the local keys or by using the key pad (which is ordered separately). When using the key pad it may not be necessary to remove the cover of the top unit.

Sensor System

The ThinkTop® features a "No Touch" sensor system without any mechanical sensor adjustments. A magnet is mounted on the valve stem and the magnetic field (axial) is detected by sensor chips inside the sensor unit. The measuring angle from each chip is used to locate the current position of the valve stem with an accuracy of $\pm 0.004''$ (0.1 mm). Note that the distance to the magnet can be $0.2''$ (5 mm) $\pm 0.12''$ (3 mm).

Feedback Signals

The sensor system can be used for 4 feedback signals + 1 status signal = 5 digital PNP/NPN feedback signals. Selection of PNP or NPN is done by a jumper. 2 of the feedback signals can be external sensors if necessary.

The status signal is used for detection of the following:

- Set-up is in progress.
- Internal error.
- Maintenance is required (based on time and/or the self adjustment program).

The LEDs are constantly indicating the status of the unit: valve position, solenoid activated, setup and local fault indication, maintenance and seat-lift.



ThinkTop®

Standard Design

The ThinkTop® has a simple, modular and robust design which ensures a quick and easy assembly/disassembly. It consists of a base containing a sensor unit with LEDs, an activator stem, terminals for internal electrical connection, solenoid valves and a shell. See also Fig. 2 "Basic Design". It is prepared for upgrading and components are interchangeable. The design is hygienic and easy to clean.

Features

Tolerance Programmes

Individual tolerance programs for all Alfa Laval sanitary valve types are part of the ThinkTop® concept ensuring correct feedback to the PLC for open and closed valve position. If the function is disabled the tolerance band will be ± 0.2" (5 mm).

Self Adjustment (SRC/ARC valves only)

The self adjustment feature is an exceptional aspect of the ThinkTop® design. A program can be activated to allow an adjustment of the tolerance band if the seals in the valve are being compressed or are worn. When the tolerance band of the unit has been adjusted 0.012" (0.3 mm), an alert warning will appear in the form of a status signal and a flashing maintenance LED. After a 0.2" (5 mm) adjustment, an alarm warning signals the following: loss of feedback, status signal, a steady maintenance light, and indicates the minimum seal remaining before replacement is required.

Built-in Maintenance Monitor

The unit can be preset to indicate when the time for maintenance of the valve has been reached. A status signal and flashing maintenance LED can be programmed to return after 3, 6, 9 or 12 months or more.

Other Features

Another very important fact is that the setup is kept until programmed otherwise even during failure in the power supply.

The accurate sensor system enables indication of seatlift to be integrated in the top unit.

Materials

- Plastic partsNylon PA 6. Reinforced.
- Steel parts:Stainless steel AISI 304 and 316.
- Seals:Nitrile (NBR). EPDM rubber for SMP-EC activator stem.

Technical Data

Sensor System:

- Sensor accuracy:± 0.004" (0.1 mm)
- Distance to magnet:0.2" ± 0.12" (5 ± 3 mm)
- Stroke length:0.004"- 3.15" (0.1 - 80 mm)

Electrical connection

Direct cable gland entry (hard wired) PG11 0.15" - 0.39" (4 - 10 mm) diameter.

Terminals

The terminal row of the sensor unit is equipped with screw terminals for both internal as well as external cables and wires. The terminals are suitable for wires up to 0.75mm² (19 AWG).

Power Supply - DC

The unit is reverse polarity and short circuit protected.

The power supply must meet the requirements of EN 61131-2.

| | | |
|--|-----------|--|
| Supply voltage: | | .8 - 30 VDC |
| Supply voltage nominal: | | .24 VDC (+20%, -15%) - pr. EN 61131-2 |
| Max. ripple 5% of nominal supply voltage | | |
| Supply voltage absolute max: | | .30 VDC |
| Supply voltage absolute min.: | | .8 VDC |
| Supply current: | | Max. 45 mA (for sensor unit alone) |
| | | (Excluding current to the solenoids, external proximity switches and the PLC input current.) |

Feedback Signals

Output signals from the sensor unit to the connected digital interface (PLC).

| | | |
|------------------|-----------|--|
| Nominal voltage: | | Must match the selected type of ThinkTop®. |
| Load current: | | Max. 100 mA |
| Voltage drop: | | Max. 2 V at max. load current. |

External Sensors

The external sensors are used for seat-lift supervision (upper seat-lift) when seat-lift cannot be internally detected. The sensors get their supply voltage from the top unit. They connect directly to the terminal strip on the sensor unit. If the actual setup is set for internal seat-lift (lower seat-lift), the corresponding external signal is not used, otherwise the external signal logically controls the corresponding feedback to the PLC (Programmable Logic Controller).

| | | |
|---------------------|-----------|--|
| Supply voltage: | | Must match the selected type of ThinkTop®. |
| Supply current: | | Max. 15 mA per sensor. |
| Type of sensor, DC: | | Only 3-wire sensor PNP. |

Polarity

PNP (sourcing) or NPN (sinking) function is selected with a jumper in terminals 12 and 13. Jumper present = PNP. If changing to NPN remove the jumper and make a power recycle. A power recycle is always required when changing this function.

3.6

Solenoid valves:

Up to 3 solenoid valves in each unit.

- Type3/2 or 5/2 valve (only possible with one 5/2 valve).
- Air supply43.5 - 130.5 PSI (3-9 bar).
- Filtered air, max. particles or dirt0.0004" (0.01 mm).
- Max. oil content1.0 ppm.
- Max. water content0.0165 lb/lb air
- Throughput0.98" (2.5 mm) diameter

3.6

Air restriction (throttle function) air inlet/outlet.
Manual hold override.

- External air tube connection1/4" or 6 mm diameter.
- Nominal voltage24 VDC
- Nominal power1.0 W.

Environment/Approvals

| | | |
|-------------------------|---|---|
| Temperature | | |
| Working: | -4° F to 185° F (-20° C to +85° C) | IEC 68-2-1/2 |
| Storage: | -40° F to 185° F (-40° C to +85° C) | IEC 68-2-1/2 |
| Temperature change: | -13° F to 212° F (-25° C to +100° C) | IEC 68-2-14 |
| Vibration | 10-55 Hz, 0.03" (0.7 mm) 55-500 Hz, 10g 3*30 min, 1 octave/minute | IEC 68-2-6 |
| Drop test | | IEC 68-2-32 |
| Humidity | | |
| Constant humidity: | 104° F (+40° C), 21 days, 93% RH | IEC68-2-3 |
| Cyclic humidity: | 77° F/131° F (+25° C/+55° C) 12 cycles 93% R.H. | IEC 68-2-30 |
| (working) | | |
| Protection class | IP67 | IEC 529 |
| Input treshold | | |
| Voltage/current: | Type 1 input requirements | EN 61131-2 |
| Solenoid signals | | |
| Isolation voltage | (1000 + 2*117) VAC rms/1minute | EN 61131-2 |
| EMC Directive | 89/336/EEC | EN 50081-1, EN 50082-2 KA 2791.30 Tetra Pak Corporate Standard |
| UL approval | ThinkTop sensor unit | UL E203255 Project # 99NK20566 |

Electrical connection, internal

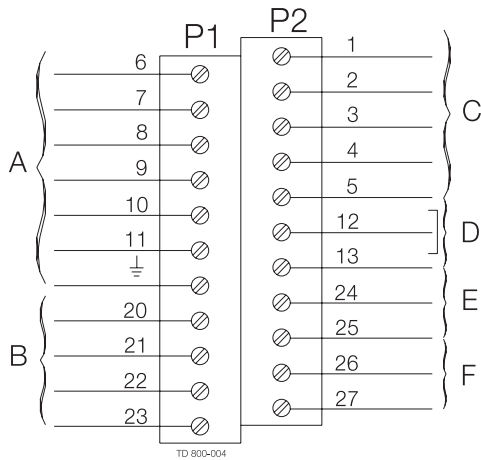

- A. Digital interface command signals
 - B. Internal connections to solenoid 1-3
 - C. Feedback signals to digital interface
 - D. Jumper connections **)
 - E. Incoming signals from external sensors
 - F. Support to external sensors
- 6. Solenoid 1
 - 7. Solenoid 2
 - 8. Solenoid 3
 - 9. Supply +
 - 10. Supply -
 - 11. Solenoid com. Earth
 - 20. Solenoid com. Earth
 - 21. Solenoid 1
 - 22. Solenoid 2
 - 23. Solenoid 3
 - 1. Closed valve
 - 2. Open valve
 - 3. Seat-lift 1
 - 4. Seat-lift 2
 - 5. Status
 - 12. NPN/PNP Jumper
 - 13. NPN/PNP Jumper
 - 24. Seat-lift 1 "upper" *)
 - 25. Seat-lift 2 "lower" *)
 - 26. Supply + *)
 - 27. Supply - *)

*) **Note!**Terminals 24, 25, 26 and 27 can be used for external seat-lift sensors as well as for any digital input. Always use an external PNP sensor. 2 external signals can be connected, they are associated with feedback signal 3 (seatlift 1) and 4 (seatlift 2). External sensor must always be a 8-30 VDC PNP 3 wire sensor. Connect (-) common on terminal 27, and (+) common on terminal 26. The signals from the external sensors are associated as follows: sensor signal on terminal 24 (seatlift 1) associated with feedback 3 (seatlift 1), and sensor signal on terminal 25 (seatlift 2) associated with feedback 4 (seatlift 2).

***) **Note!**Jumper present = PNP. If changing the function a power recycle is necessary. The selection NPN/PNP is done by the jumper.

Note! Remember to isolate wires that are not in use.

Example of connecting power supplies

One power supply for sensor system and solenoid valves:

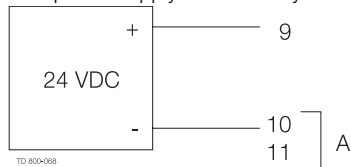

A) Jumper (if positive activation of solenoids)

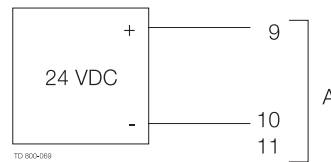

B) Jumper (if negative activation of solenoids)

Two power supplies, one for sensor system and one for the solenoid valves:

Sensor system

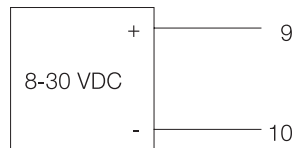

Solenoid valves

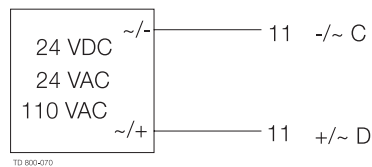

- C) If positive activation of solenoids
- D) If negative activation of solenoids

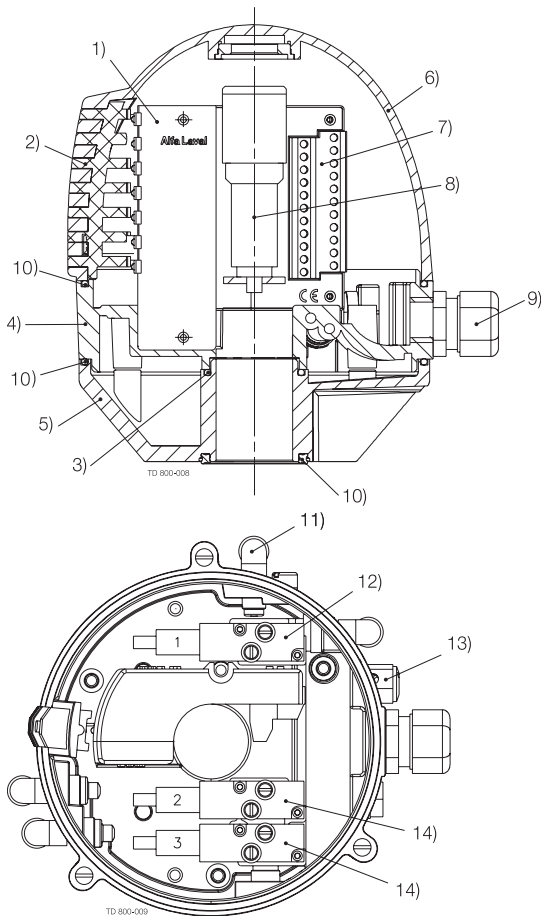
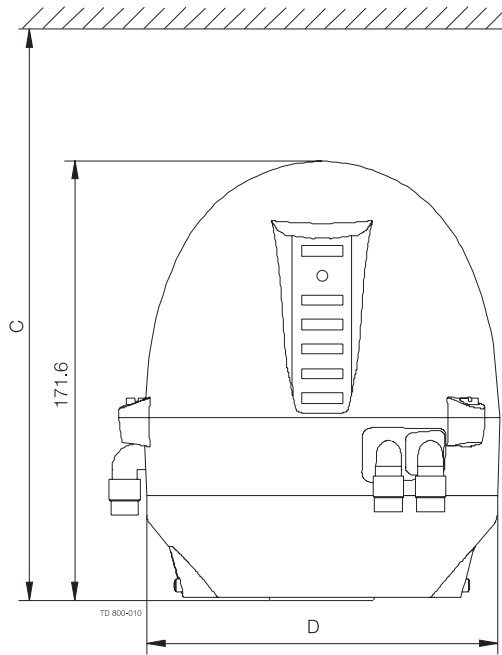

Fig. 2. Basic design, ThinkTop®.

- 1. Sensor unit
- 2. Light guide
- 3. O-ring
- 4. Base
- 5. Adapter
- 6. Shell
- 7. Terminals
- 8. Activator stem
- 9. Cable gland
- 10. Special X-ring
- 11. Air fitting
- 12. Solenoid valve (3/2 or 5/2)
- 13. Safety valve
- 14. Solenoid valve (3/2)

Note!1.) The ThinkTop® for the SMP-EC valve has a longer activator stem which is going through the shell (see Ordering Leaflet).
 2.) The ThinkTop® for the SRC-LS requires a special magnet.
 Contact Alfa Laval.



***Note!**This is the basic design. The clearance should be approximately:
 7.1" dia. x 9.8" (ø180 x 250 mm) (SRC NC, SMP-SC/-BC/- TO, Unique, Koltex MH, SBV, AMP)
 7.1" dia. x 12.6" (ø180 x 320 mm) (SRC NO)
 7.1" dia. x 11.8" (ø180 x 300 mm) (LKB/LKLA-T)

Options

- Solenoids 24 VAC, 110 VAC.
- 5 m PVC control cable 12 x 0.5 mm², (24 AWG).

Accessories

- IR keypad.
- External indication bracket for SMP-SC.

Note! The ThinkTop® has Patented Sensor System, Registered Design and Registered Trademark.

Ordering

Please state the following when ordering:

- Digital 8-30 V DC PNP/NPN.
- Number of solenoids (0-3).
- Type of valve (3/2, 5/2).
- Air connection ø6mm or 1/4"
- Please state if SMP-EC.