



Many innovations and new technologies in the mixproof valve industry can be attributed to Alfa Laval.

## Mixproof Valves

### Advanced Valve Technology

Alfa Laval, the world's largest flow equipment company, brings you the most advanced mixproof technology available for dairy, food, beverage, brewery and biopharm applications.

Mixproof valve technology has truly revolutionized the sanitary flow industries. With a double-seat mixproof design, you're able to stream two different products or CIP fluid through the same valve at the same time – without any risk of cross contamination. In effect, one mixproof valve can do the job of two or three single-seat valves, saving you space and installation costs and providing you with unmatched system flexibility.

The new *Unique* mixproof valve design offers complete customized and modular design. The valve is spillage-free during operation, providing optimum hygienic conditions. During the research and development of the *Unique* mixproof valve, a comprehensive market survey formed the corner stone, thus ensuring that the specific requirements of the end user would be covered by the valve.

Read on to find out how this series of mixproof valves:

- Fits exactly to your process, no more & no less
- Includes a very reliable design
- Offers our exclusive **SpiralClean** system for ultimate hygienic performance
- Features simple installation
- Requires minimal service and maintenance
- Is authorized to carry the 3A symbol



The new *Unique* mixproof valve featuring the Alfa Laval modular concept.

## *Unique* – Fit to any process

Extensive worldwide research in the marketplace has shown that no single valve has been able to fulfill all process requirements, until now.

The *Unique* mixproof valve is designed with user flexibility in mind. These valves can be tailored exactly to the features you need for your specific application – so you're not paying for features you don't need. And, if you do need extra functionality in the future, they can be added to your existing valve.

Due to the modular nature of the *Unique* mixproof valve, there are many options available when specifying a valve. Some are balanced and unbalanced plugs, seat lift, CIP for the plugs, leakage chambers and any combination in between! In fact, it's possible to change the configuration from an unbalanced to a balanced plug with external CIP just by changing three parts of the valve. All other components remain the same.

One of the major benefits of customizing the *Unique* mixproof valve to your application is that you only get the features you need. That way, you only experience wear on the parts used and aren't spending time maintaining functions not actually used. Even further, there is no risk of problems occurring on the features/functions outside your needs.

This approach also means economy on all sides: economy when purchasing, economy when using and economy if upgrades are needed. When purchasing the correct valve for the process, options can be specified from a very long list of configurations.

This means that you only pay for the features you want, saving you money! When upgrading, like adding a CIP function, the same valve body is used and only the upgraded parts need to be added. And since the *Unique* valve family uses the same spare parts, stocking spares is easy.

Here are some of the features you can choose from, and combine in any way you want:

- Upper plug balanced or unbalanced
- Upper plug with or without external CIP connections
- Lower plug balanced or unbalanced
- Lower plug with or without external CIP connections
- Seat lift integrated in the actuator
- External CIP or leakage chamber

## Unique – *SpiralClean* system

The innovative *SpiralClean* system offers many benefits and economies. It cleans more efficiently, uses less cleaning fluid and can be fitted to both the upper and lower plugs, as well as the leakage chamber or any combination of them.

All external CIP systems for the *Unique* mixproof valve include the *SpiralClean* design as standard.

The *SpiralClean* system is a great example of how small details in the design characteristics can have a major impact on the result. By controlling the CIP flow patterns, the cleaning effects of the fluid are increased considerably and thereby require a much shorter cleaning cycle.

The *SpiralClean* system ensures that a directional flow of CIP fluid reaches all the surfaces in much less time than with conventional systems. The direction of attack is designed to enhance the cleaning action, meaning less fluid has to be used to achieve the same level of cleanliness.

The *SpiralClean* system exploits both gravity and centrifugal forces in the cleaning process.

Also, the *SpiralClean* feature is a part of the modular concept and can be specified at purchase or added to an existing *Unique* valve. Innovative design means that simple changes to the internal parts can upgrade a *Unique* valve to include CIP for the upper plug, lower plug or leakage chamber.

Another benefit from the *SpiralClean* system is that it allows the *Unique* mixproof valve to run under aseptic-like conditions. If you apply steam to the CIP pipes, this will form a steam barrier to the atmosphere.

The spray nozzle and the angle on the inlet pipe gives the *SpiralClean* effect.



The spray turbine with the specially designed groove.

Few, very simple parts provide the unique *SpiralClean* CIP connections.



Components of the new modular concept add versatility and efficiency to our mixproof valves.

## Unique – Features you can rely on

### Reliable

The *Unique* valves have several features that add up to an extremely reliable valve. The valve is designed so that only the parts in use are exposed to wear, optimizing the service intervals.

When the valve opens, the radial gasket slides inside the upper plug. In this way, the radial gasket is always protected in use and easily cleaned using the seat lift option. When the valve is closing, the upper plug moves into its axial seat. Then, the lower plug with the radial seal moves into position. Through this defined movement, the friction on the radial seal is kept to a minimum, thus prolonging its life. The leakage chamber is designed with a restriction on the CIP inlet flow, which prevents any form of pressure build-up in the chamber.

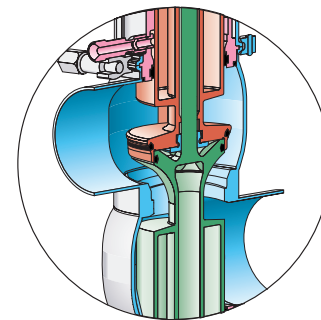
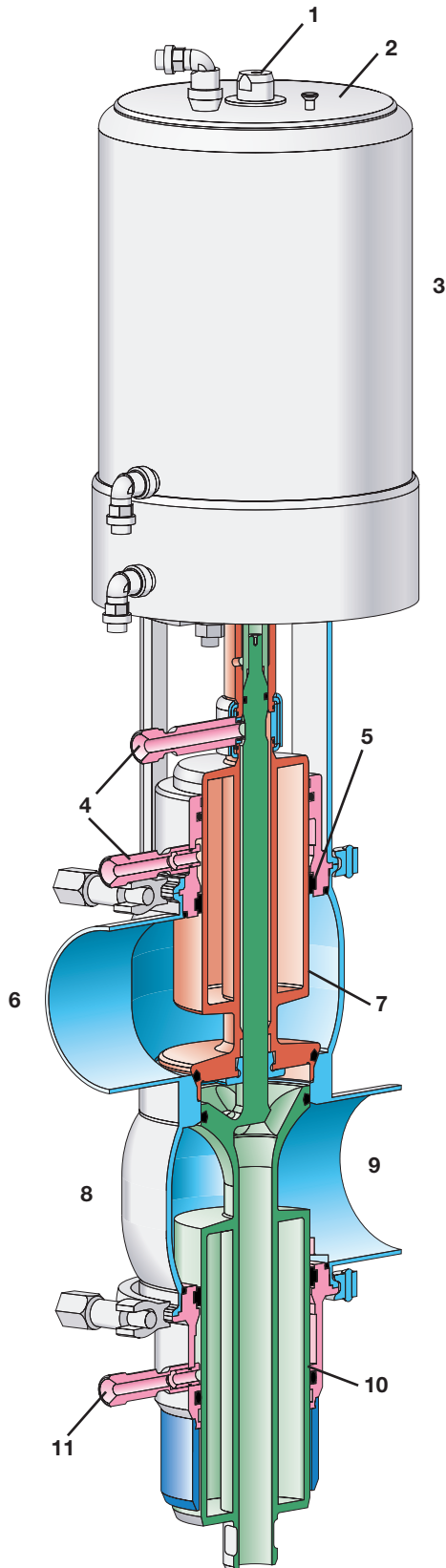

**Open Valve.** The radial seal is fully protected in the open position.

### Simple and cost-effective maintenance

There is no need for mechanical adjustment of the *Unique* mixproof valve plugs, saving time during installation and maintenance. Simple assembly of this valve is the key to easy and effective maintenance. The *Unique* mixproof valve consists of a limited number of different parts and a minimum number of seals, adding up to extremely simple handling of the valve during service and maintenance.

1. No mechanical adjustment of valve plug
2. **ThinkTop** ready
3. Maintenance-free and repairable actuator
4. External CIP available (optional) for leakage chamber, upper and lower plugs, in any combination
5. Double lip seal-pressure and vacuum means no contamination
6. Welded body – minimum number of seals, optimum hygienic conditions (clamped body optional)
7. Upper-balanced plug (optional)
8. Rigid 4mm 316L Stainless Steel valve body
9. “Pulled-out” ports
10. Lower-balanced plug (optional)
11. Lower plug External CIP (optional)

## Unique – Designs to fit your application

### Standard configurations

When configuring a valve, the key issue in most cases is the actual application. It is vital that the valve is able to perform under the anticipated conditions and that it can be properly cleaned during the normal cleaning procedures. To assist you in the selection, we have included some standard configurations of this *Unique* mixproof valve.

- *Unique* **Basic**
- *Unique* **SeatClean**
- *Unique* **HighClean**
- *Unique* **UltraClean**
- *Unique* **PMO**

You can either choose one of these standard configurations or include specific features to ensure that the valve matches your process needs. And, all the *Unique* mixproof valves are authorized to carry the 3A symbol.



### *Unique* **Basic** – for low cost and CIP solutions

This configuration of the *Unique* **Basic** mixproof valve uses the basic components, providing safety and leakage detection. The typical applications could be water inlet for water push of product or CIP supply and return lines. This basic valve is not suitable in applications with risk of pressure shocks or sticky products.

### *Unique* **SeatClean** – for standard solutions

- Actuator with seat lift integrated
- Balanced lower plug

This is the standard configuration of the *Unique* **SeatClean** mixproof valve, designed to meet the typical demands of a process valve in the food and beverage industries. The plugs and seats are cleaned by means of a seat lift during normal cleaning procedures. This valve also includes a balanced lower plug that eliminates the risk of mixing products by pressure shock or when the pressure in the pipe is high.

### *Unique* **PMO** – for compliance with Pasteurized Milk Ordinance drainage requirements

- Actuator with seat lift integrated

The *Unique* **PMO** valve meets the Pasteurized Milk Ordinance (PMO) criteria for dairy operations. It provides separation of milk products and cleaning solutions, eliminating the need for manual pipe swing connections.



*Unique* **Basic**



*Unique* **SeatClean**



*Unique* **PMO**



#### Unique HighClean – for high hygienic solutions

- Balanced lower and upper plugs
  - **SpiralClean** of leakage chamber, upper and lower plugs
- When you are dealing with sticky products or products with high contents of solids, the **Unique HighClean** mixproof valves are sure to meet your processing needs. The HighClean uses our patent pending **SpiralClean** system to meet the high hygienic standards of the sanitary flow industry. With balanced plugs, the **Unique HighClean** protects against high pressure and water hammer effect.

#### Unique UltraClean – the highest hygienic solution

- Actuator with seat lift integrated
  - Balanced lower and upper plugs
  - **SpiralClean** of leakage chamber, upper and lower plugs
- To meet the highest demands for hygienic processing, look to the **Unique UltraClean** from Alfa Laval. During the cleaning process, the plugs are lifted independently to ensure the plugs and seats are cleaned together with their corresponding pipe. At the same time, the leakage chamber and balanced plugs are cleaned with our patent pending **SpiralClean** system. This configuration also protects against high pressure and water hammer effect, has few product wetted seals and allows no product spillage during operation.

### Other Mixproof Valves

#### SMP-TO Tank Outlet

The SMP-TO is specifically designed for mixproof tank outlet operations where cleaning pipelines up to the bottom of the tank is required. The compact design offers substantial space saving benefits. The radial sealing between the two valve plugs ensures that no product is lost when the valve is open. The lower plug seating means that high pressure or pressure shock will not affect the plug position. Because the lower plug can be independently lifted, it can be cleaned without the need for external CIP.

#### Other benefits of the SMP-TO include:

- The valve's external stem is cleaned automatically during seat lift
- Independent seat lift of lower plug
- No leakage during operation
- Simple and easy maintenance
- Compact design easily fits under tank



SMP-TO

## SMP-BC

The SMP-BC mixproof valve is specifically engineered for applications where additional safety and leak detection are desirable. Because the SMP-BC is based on the proven SRC seat valve design, many parts are common to both valves. The easily accessible seals can be replaced from the top.

For optimum installation flexibility, the SMP-BC is available as a shut-off valve with one valve body or as a divert valve with three valve bodies.

### Other features of the SMP-BC include:

- Safe leak detection
- Independent cleaning of chamber
- Cost effectiveness



SMP-BC



SMP-BCA Aseptic

## SMP-BCA Aseptic

The SMP-BCA is an aseptic version of our BC mixproof valve, designed to handle the high sterilization temperatures of aseptic applications.



*ThinkTop*® has a registered design and patented sensor system.

## *ThinkTop*® – Control and indication

### For optimum valve control

*ThinkTop*® offers the most advanced automated control of valves in the industry. Whether you're modifying an existing plant or planning a new installation, *ThinkTop* is right for your process.

*ThinkTop*'s registered design features the modularity and flexibility like no other control unit Alfa Laval has ever offered.

In addition, *ThinkTop*:

- is self-adjusting when installed
- can be set up without dismantling or readjusting
- fits all the mixproof valves featured in this brochure and all other air-operated sanitary valves from Alfa Laval
- includes a wide-range of interface modules
- features an integrated indication of seat lift
- offers the ability to integrate external signals in the top
- saves set-up parameters until reprogrammed – even in case of power failure

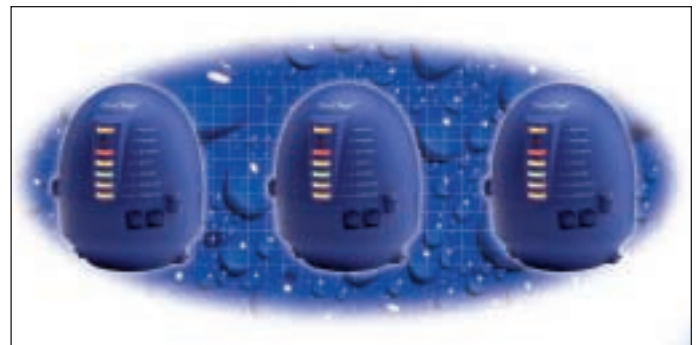

Digital

AS-Interface

DeviceNet

## Flexible Operation

The ability to operate with a variety of interface modules is yet another benefit of *ThinkTop*.

Three levels of communication, including Digital, AS-Interface (simple BUS system) and DeviceNet (advanced BUS system), are all compatible with the *ThinkTop* control unit.

## Sensor Principle

*ThinkTop*'s unique, patented sensor system can retain its feedback signal over time. Microchips within the sensor system calculate the current position of the valve stem at set-up, and it is stored in the unit's memory.

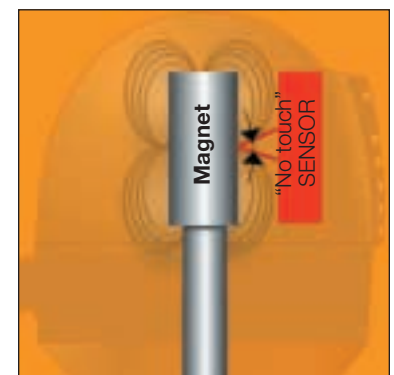

## Providing the world with processing solutions.

Alfa Laval is a leading global provider of specialized products and engineering solutions. Our equipment, systems and services are dedicated to assisting customers in optimizing the performance of their processes, time and time again. We help them heat, cool, separate and transport products such as oil, water, chemicals, beverages, foodstuff, starch and pharmaceuticals. Our worldwide organization works closely with customers in almost 100 countries to help them stay ahead.

Our U.S.-based sanitary group offers Alfa Laval and Tri-Clover fluid handling and heat transfer equipment. Since 1919, Tri-Clover has been the leading supplier of processing equipment to the sanitary flow industry in North America. Part of Alfa Laval since 1986, Tri-Clover's sales and marketing functions were consolidated within the overall Alfa Laval organization in December 2000, creating the undisputed global leader in this industry. Tri-Clover remains a key brand within Alfa Laval.

### Alfa Laval

8201 104th Street  
P.O. Box 581909  
Pleasant Prairie, WI 53158-0909  
USA  
Tel: 800-558-4060  
Fax: 262-947-4728



[www.alfalaval.com](http://www.alfalaval.com)