

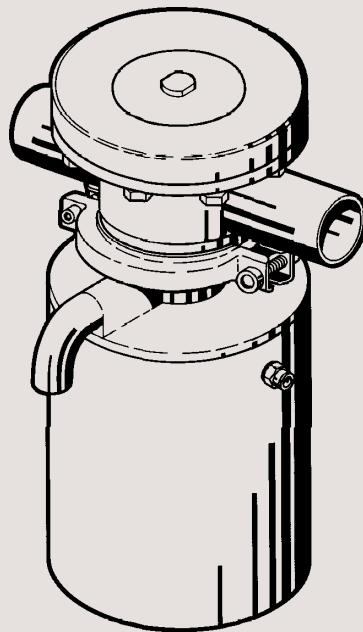

Instruction Manual

SMP-TO Sanitary Mixproof Tank Outlet Valve



Declaration of Conformity

The designating company

Alfa Laval

Company Name

6000 Kolding

Address

+45 79 32 22 00

Phone No.

hereby declare that

SANITARY MIXPROOF TANK OUTLET VALVE

Denomination

SMP-TO

Type

Year

Was manufactured in conformity with the provisions in the COUNCIL DIRECTIVE on mutual approximation of the laws of the Member States on the safety of machines (98/37/EC) with special reference to Annex 1 of the directive on essential safety and health requirements in relation to the construction and manufacture of machines.

Bjarne Søndergaard

Name

Vice President, R & D

Title

Alfa Laval

Company

B. Søndergaard

Signature

Designation

CE

Table of contents

This manual is divided into main sections. - See below.

Safety

1. Important information	2
2. Warning signs	2
3. Safety precautions	3

Installation

1. Unpacking/Delivery	4
2. General installation	5
3. Welding	6

Operation

1. Operation	7
2. Fault finding	7
3. Recommended cleaning	8

Maintenance

1. General maintenance	10
2. Dismantling	12
3. Assembly	14
4. Replacement of plug seals	16
5. Scrapping of actuator	18

Technical data

1. Technical data	19
-------------------------	----

Drawings/Parts list

1. Parts list	
- SMP-TO	20+22
- Tool for plug seals	24+26
2. Exploded drawing	
- SMP-TO	21
- Tool for plug seals	25
3. Drawing	
- SMP-TO	23
- Tool for plug seals	27

Safety

Unsafe practices and other important information are emphasized in this manual.

Warnings are emphasized by means of special signs.

1. Important information

Always read the manual before using the valve!

2

- WARNING!** : Indicates that special procedures **must** be followed to avoid severe personal injury.
- CAUTION!** : Indicates that special procedures **must** be followed to avoid damage to the valve.
- NOTE!** : Indicates important information to simplify practices or to make them clearer.

2. Warning signs



: General warning.



: Caustic agents.

All warnings in the manual are summarized on this page.

Pay special attention to the instructions below so that severe personal injury and/or damage to the valve are avoided.

3. Safety precautions

Installation:



- : - **Always** read the technical data thoroughly (see page 19).
- **Always** release compressed air after use.



- : **Never** stick your fingers through the valve ports if the actuator is supplied with compressed air.

Operation:



- : **Always** read the technical data thoroughly (see page 19).



- : **Never** touch the valve or the pipelines when processing hot liquids or when sterilizing.



- : **Always** handle lye and acid with great care.



- : **Never** throttle the leakage outlet.

Maintenance:



- : - **Always** observe the technical data thoroughly (see page 19).
- **Always** fit the rubber seals correctly (risk of mixing).
- **Always** release compressed air after use.
- **Always** supply compressed air carefully and turn piston (19) downwards when removing it.



- : - **Never** service the valve when it is hot.
- **Never** service the valve with valve and tank/ pipelines under pressure.



- : **Never** stick your fingers through the valve ports if the actuator is supplied with compressed air.



- : **Always** release the actuator springs before scrapping the actuator (see special scrapping instructions on page 16).

Installation

4

The instruction manual is part of the delivery.
Study the instructions carefully.

The items refer to the drawings and parts list on the
pages 20-23.

1. Unpacking/Delivery

1

CAUTION!

We cannot be held responsible for incorrect un-
packing.

Check the delivery for:

1. Complete valve (see 2).
2. Delivery note.
3. Instruction manual.

2

Standard delivery:

1. Valve with actuator.
2. Tank flange (1) and counterflange (2).
3. Welding flange (28) and counterflange (29)
(option for tanks with tube outlet).

3

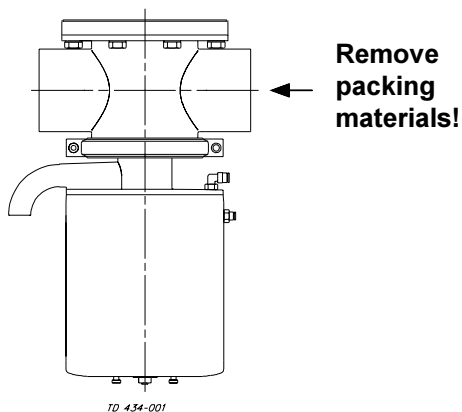

Clean the valve ports for possible packing materi-
als.

4

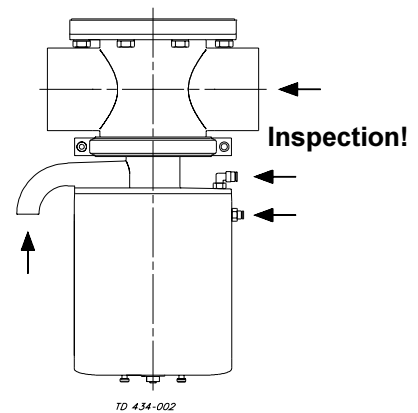

Inspect the valve for visible transport damages.

5

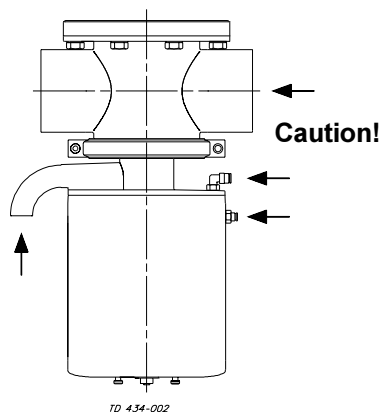

Avoid damaging the air connections, the leakage
outlet and the valve ports.

Study the instructions carefully and pay special attention to the warnings!

The valve has welding ends as standard but can also be supplied with fittings.

2. General installation

1



- **Always** read the technical data thoroughly (see page 19).
- **Always** release compressed air after use.

CAUTION!

We cannot be held responsible for incorrect installation.

2

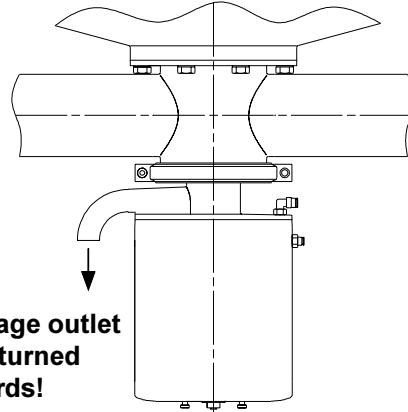

The leakage outlet must be turned downwards!

TD 434-003

Always install the valve vertically.

3

Risk of damage!

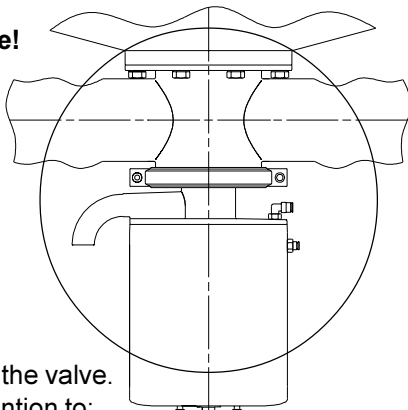

Avoid stressing the valve.
Pay special attention to:

- Vibrations.
- Thermal expansion of the tubes.
- Excessive welding.
- Overloading of the pipelines.

TD 434-004

4

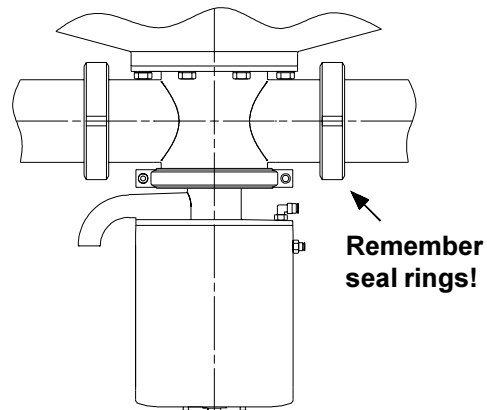

Remember seal rings!

TD 434-005

Fittings:

Ensure that the connections are tight.

5

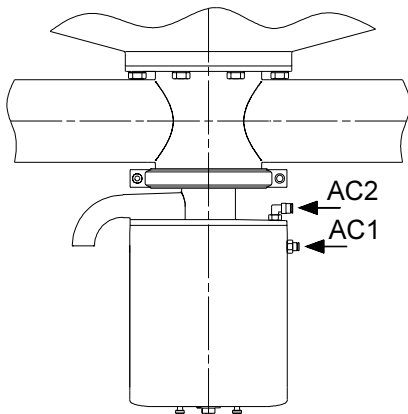

TD 434-006

Air connection: R 1/8" (BSP).
AC1: Cleaning of seat.
AC2: Open valve.

6

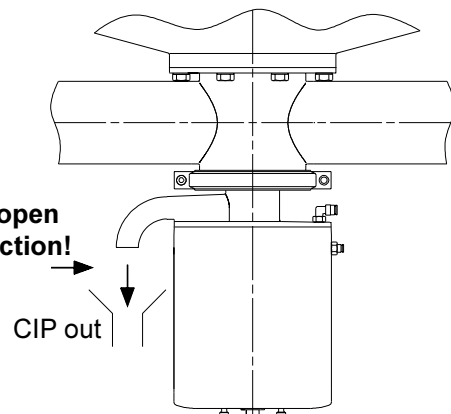

TD 434-007

CIP connection:

1. See the description of cleaning on page 8.
2. Connect CIP correctly.

Installation

Study the instructions carefully and pay special attention to the warnings!

The valve has welding ends as standard.
Weld carefully.

The items refer to the drawings and the parts list on pages 20-23.

3. Welding

1

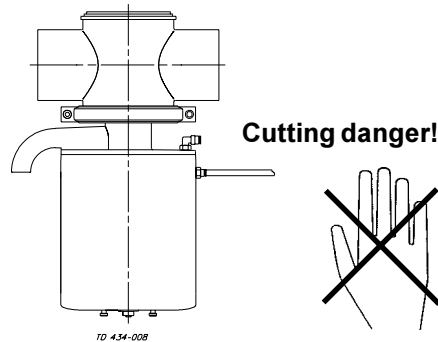

! Never stick your fingers through the valve ports if the actuator is supplied with compressed air.

Dismantle the valve in accordance with instructions 1-3 on page 12.

Pay special attention to the warnings!

2

Sizes	øA	øB
All	104	100
All	101.6	97.6

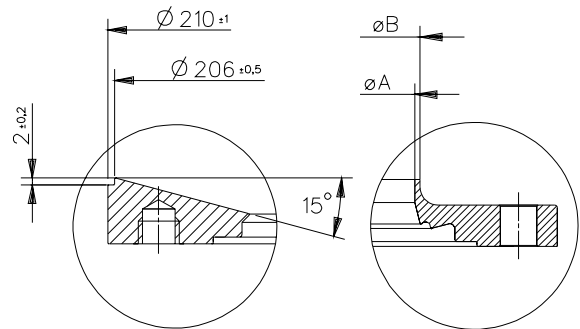

Tank flange **Welding flange**
Flange types: Tank flange, Welding flange.

3

1. Weld the flange into the tank.
2. Maintain the minimum clearance A so that the actuator with the internal valve parts can be removed.

Valve size	A (mm)
DN65/63.5 mm	672
DN100/101.6 mm	706

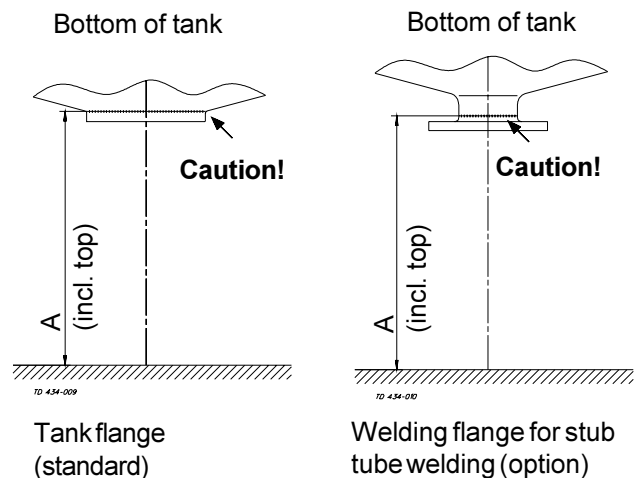

4

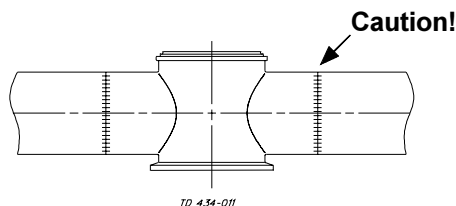

Weld the valve body into the pipelines.

NOTE!

Always weld the valve body into the pipelines so that seal ring (5) (option (11)) can be replaced.

5

Assemble the valve in accordance with instructions 8-11 on page 15.

Pay special attention to the warnings!

Pre-use check!

1. Supply compressed air to the actuator.
2. Open and close the valve several times to ensure that it operates smoothly.

Pay special attention to the warnings!

The valve is adjusted and tested before delivery. Study the instructions carefully and pay special attention to the warnings!

Pay attention to possible faults. The items refer to the drawings and parts list on the pages 20-23.

1. Operation

1

 **Always** read the technical data thoroughly (see page 19).

CAUTION!

We cannot be held responsible for incorrect operation.

2

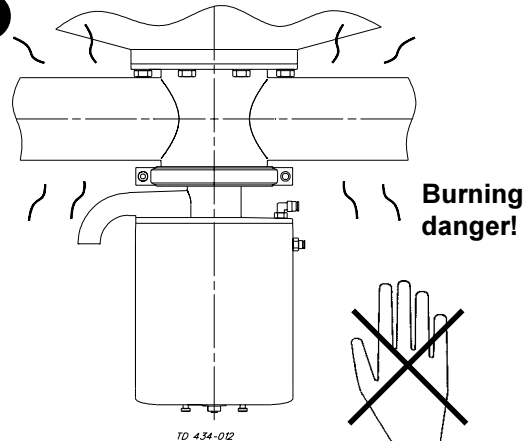

 **Never** touch the valve or the pipelines when processing hot liquids or when sterilizing.

2. Fault finding

NOTE!

Study the maintenance instructions carefully before replacing worn parts. - See page 10!

Problem	Cause/result	Repair
Product leakage through the the leakage outlet	<ul style="list-style-type: none"> - Worn/product affected seals (8b, 9b, 9c, 11) - Incorrect fitted seals (8b, 9b, 9c, 11) - Particles /solids between the plug and the seat 	<ul style="list-style-type: none"> - Replace the seals - Select a different rubber grade - Fit the seals correctly - Check for jammed particles/ solids - Frequent cleaning
Air leakage through the leakage outlet	Worn O-rings (8f, 15)	Replace the O-rings
Product leakage from counter flange (2)	<ul style="list-style-type: none"> - Worn/product affected O-ring (5) - Incorrect assembly 	<ul style="list-style-type: none"> - Replace the O-ring - Select a different rubber grade - Check the O-ring position
Product leakage from the indication hole in bonnet (13)	<ul style="list-style-type: none"> - Worn/product affected O-ring (10) 	<ul style="list-style-type: none"> - Replace the O-ring - Select a different rubber grade

Operation

The valve is designed for cleaning in place (CIP).
CIP = Cleaning In Place.

Study the instructions carefully and pay special attention to the warnings!

NaOH = Caustic Soda.

HNO₃ = Nitric acid.

8

3. Recommended cleaning

1

Caustic danger!



Always use rubber gloves!



Always use protective goggles!



Always handle lye and acid with great care.

3

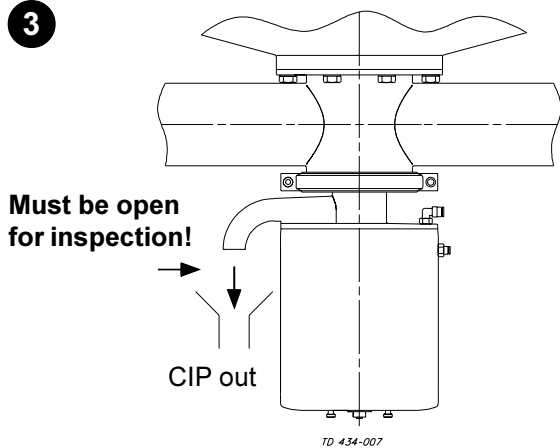

Never throttle the leakage outlet.
(Risk of mixing because of overpressure).

5

Recommended cleaning periods:
Cleaning periods of 10-15 seconds for the leakage chamber.

Product	Periods
Milk	1-2
Yoghurt	3-5
Beer	2-5
Cold wort	5-10

2

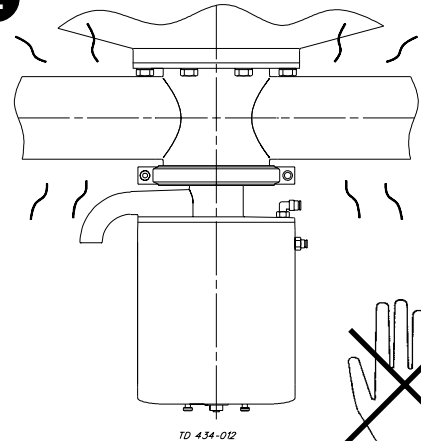

Never touch the valve or the pipelines when sterilizing.

4

Examples of cleaning agents:

Use clean water, free from chlorides.

1. 1% by weight NaOH at 70°C.

1 kg NaOH + 100 l water = Cleaning agent.

2.2 l 33%NaOH + 100 l water = Cleaning agent.

2. 0.5% by weight HNO₃ at 70°C.

0.7 l 53% HNO₃ + 100 l water = Cleaning agent.

6

1. Avoid excessive concentration of the cleaning agent

⇒ **Dose gradually!**

2. Adjust the cleaning flow to the process

Milk sterilization/viscous liquids

⇒ **Increase the cleaning flow!**

Internal leakage in the valve is externally visible by means of the leakage outlet.

Study the instructions carefully.

3. Recommended cleaning

7

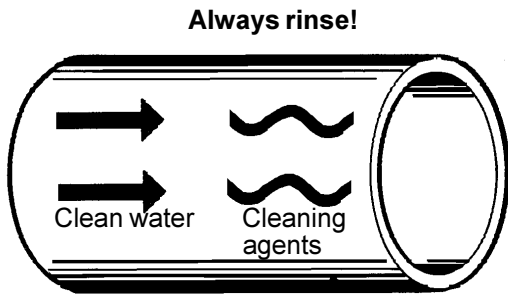

8

CAUTION!

The cleaning agents must be stores/disposed of in accordance with current rules/directives.

Always rinse well with clean water after the cleaning.

Cleaning cycle:
Pay special attention to the warnings!

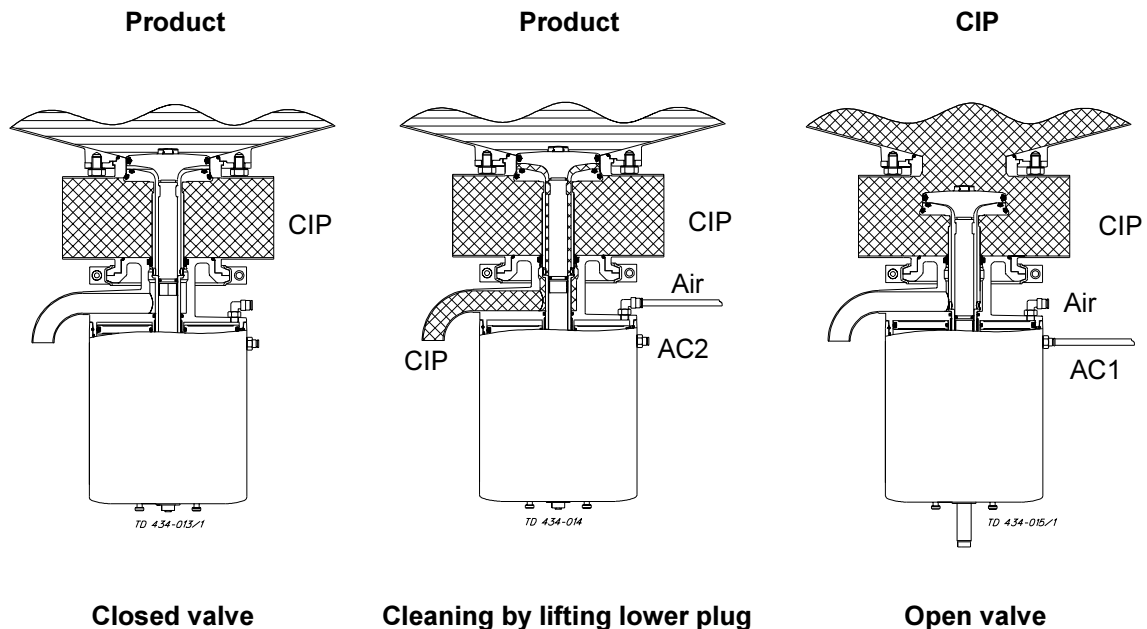

Maintenance

10

Maintain the valve carefully.
Study the instructions carefully and pay special attention to the warnings!

Always keep spare rubber seals and guide rings in stock.

1. General maintenance

1



- **Always** read the technical data thoroughly (see page 19).
- **Always** fit the rubber seals correctly (risk of mixing).
- **Always** release the compressed air after use.
- **Always** supply compressed air carefully and turn piston (19) downwards when removing it.

CAUTION!

- All scrap must be stored/disposed of in accordance with current rules/directives.
- Scrapping of actuator (see special scrapping instructions on page 18).

2

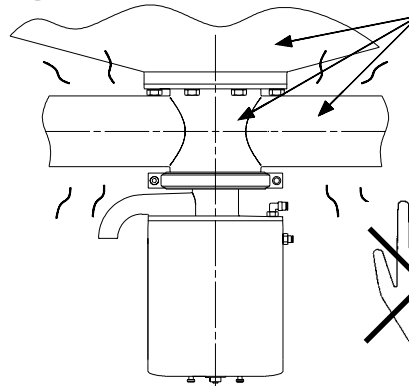

Atmospheric pressure and empty tank required!

Burning danger!



- **Never** service the valve when it is hot.
- **Never** service the valve with valve and tank/pipelines under pressure.

3

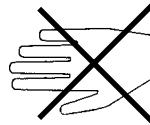
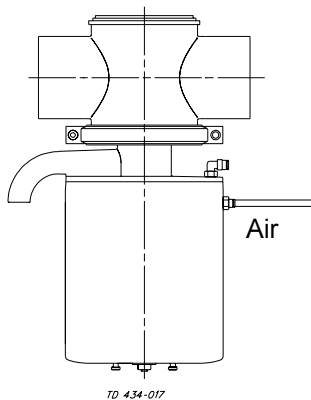

Cutting danger!



Never stick your fingers through the valve ports if the actuator is supplied with compressed air.

4

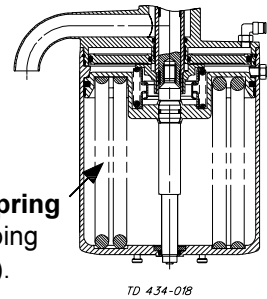

- **Caution!**

Uncaged spring
(See scrapping instructions).



Always release the actuator springs before scrapping the actuator (see special scrapping instructions on page 18).

Ordering spare parts

- Contact the Sales Department.
- Order from the Spare Parts List.

Recommended spare parts: Service kits (see Spare Parts List).

The valve is designed so that single internal leakages do not result in the products becoming mixed. Internal leakage in the valve is externally visible. Study the instructions carefully.

Always keep spare rubber seals and guide rings in stock. Check the valve for smooth operation after service.

1. General maintenance

	Product wetted seals	Other rubber seals	Guide rings
Preventive maintenance	Replace after 12 months	Replace when replacing the product wetted seals	Replace when replacing the rubber seals
Maintenance after leakage (leakage normally starts slowly)	Replace at the end of the day	Replace when possible	
Planned maintenance	<ul style="list-style-type: none"> - Regular inspection for leakage and smooth operation - Keep a record of the valve - Use the statistics for planning of inspections Replace after leakage	<ul style="list-style-type: none"> - Regular inspection for leakage and smooth operation - Keep a record of the actuator - Use the statistics for planning of inspections Replace after air leakage	Relace when replacing the rubber seals
Lubrication	Before fitting Klüber Paraliq GTE 703 or similar USDA H1 approved oil/grease	Before fitting Mobile grease 29 Alternative: Molycote Longterm + 2 or Molycote BR2	None

NOTE! (See pages 20-21).

- Product wetted seals : Pos. 5, 8b, 8d, 8f, 9b, 9c, 10, 11, 15
- Other seals : Pos 17, 18, 20

Repairing of actuator:

- The actuator is maintenance-free.
- If worn, replace the complete actuator (see special scrapping instructions on page 18).

Pre-use check:

1. Supply compressed air to AC1 and AC2 one by one.
 2. Operate the valve a few times to ensure that it operates smoothly.
- Pay special attention to the warnings!**

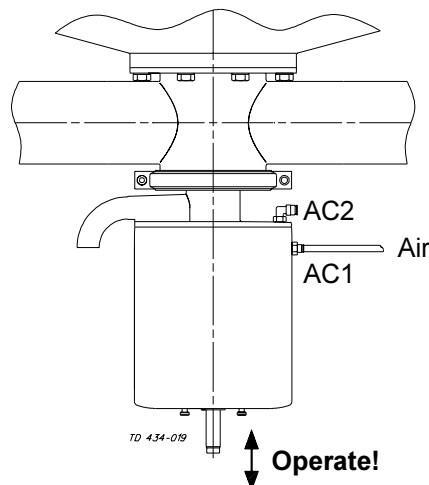

Maintenance

12

Study the instructions carefully.
The items refer to the drawings and the parts list on pages 20-23.

Handle scrap correctly.
See special scrapping instructions on page 18 when scrapping the actuator.

2. Dismantling

1

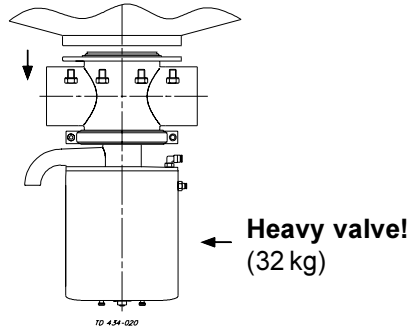

1. Remove screws (4) and washers (3).
2. Remove counter flange (2).
3. Remove the valve from the tank.

NOTE!

Remove the valve carefully.
Weight: 32 kg.

2

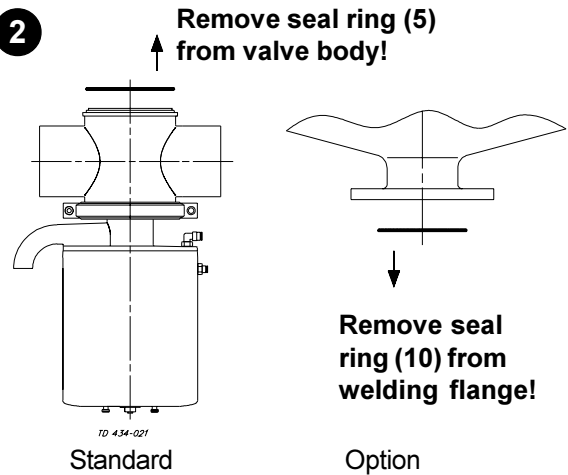

Remove seal ring (5), (seal ring (10) for welding flange).

3

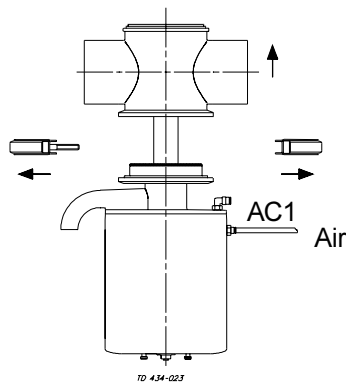

1. Supply compressed air to AC1.
2. Loosen and remove clamp (6).
3. Remove valve body (7).
4. Release compressed air.

Pay special attention to the warnings!

4

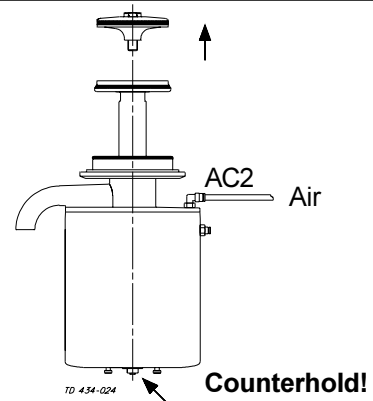

1. Supply compressed air to AC2.
2. Loosen and remove upper plug assembly (8a, 8b, 8c).
3. Release compressed air.

Pay special attention to the warnings!

5

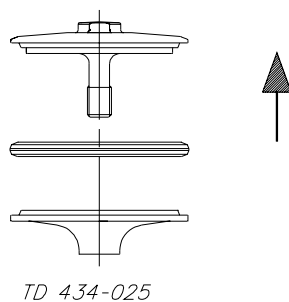

Dismantle upper plug (8a, 8b, 8c).

6

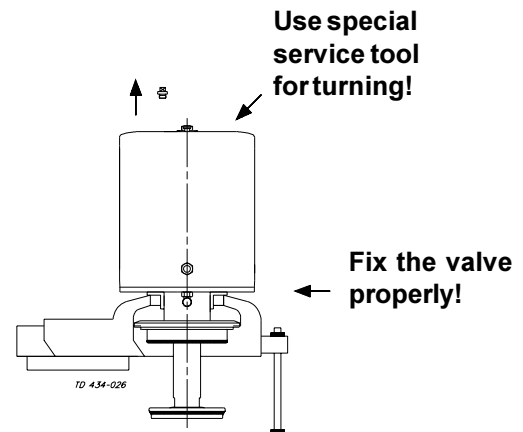

1. Remove air plug (25) from the actuator.
2. Turn the actuator and remove lock wire (14).
3. Remove the actuator from bonnet (13).

Study the instructions carefully.
The items refer to the drawings and the parts list on pages 20-23.

Handle scrap correctly.
See special scrapping instructions on page 18 when scrapping the actuator.

2. Dismantling

7

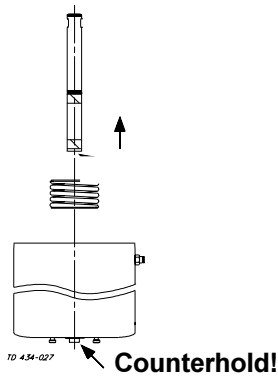

1. Remove upper stem (8e) from the actuator.
2. Remove O-rings (8d, 8f) and guide rings (8g) from the stem.
3. Remove spring assembly (22) from the actuator.

8

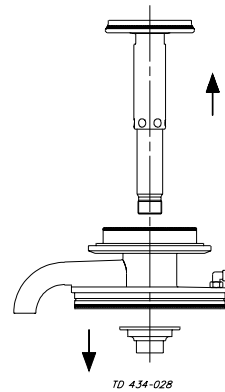

1. Dismantle support ring (21) and lower plug (9) and remove them from bonnet (13).
2. Remove seal rings (9b, 9c) from the plug (see special instructions on page 16).

9

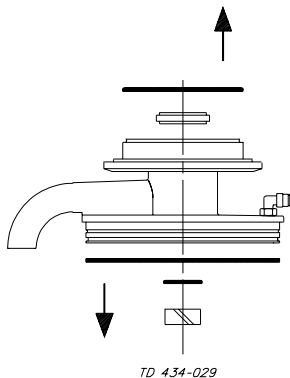

Remove O-rings (10, 15, 17), lip seal (11) and guide ring (16) from bonnet (13).

10

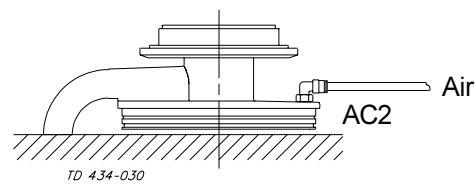

Turn piston (19) downwards!

1. Turn bonnet (13) correctly.
2. Supply compressed air to AC2 to release piston (19) carefully.
3. Release compressed air.

Pay special attention to the warnings!

11

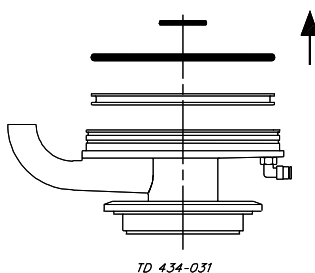

1. Turn bonnet (13) upside down.
2. Remove piston (19).
3. Remove O-rings (18, 20) from the piston.

12

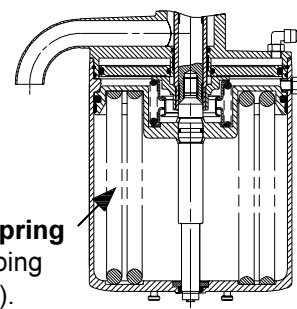

- Caution!

Uncaged spring
(See scrapping instructions).

Scrapping of actuator:

Handle the actuator correctly when scrapping it (see special scrapping instructions on page 18).

Maintenance

Study the instructions carefully.
The items refer to the drawings and the parts list on pages 20-23.

Lubricate the rubber seals before fitting them.
Fitting of plug seals, please see special instructions on page 16.

3. Assembly

1

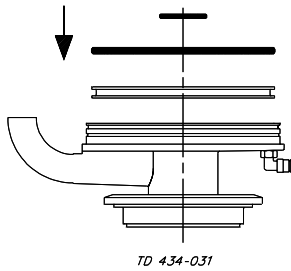

1. Fit O-rings (18, 20) in/on piston (19).
2. Fit the piston in bonnet (13).

2

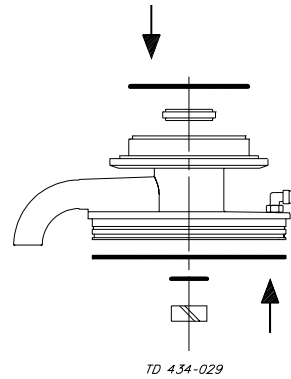

- Fit O-rings (10, 15, 17), lip seal (11) and guide ring (16) in bonnet (13).

3

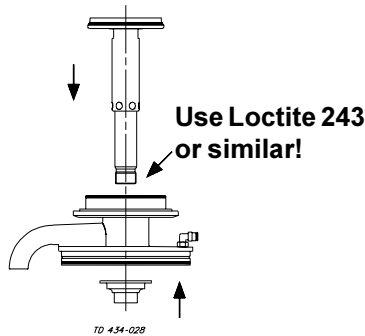

1. Fit seal rings (9b, 9c) on lower plug (9), (see special instructions on page 16).
2. Fit the plug through bonnet (13).
3. Fit support ring (21) on the plug and tighten.

CAUTION!

Do not damage lip seal (11), (fit the plug without turning it).

4

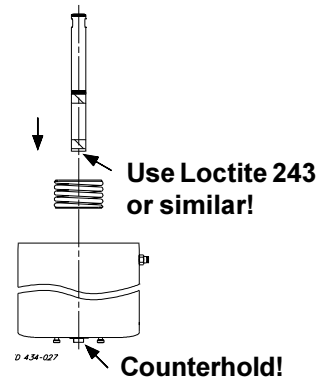

1. Fit spring assembly (22) in the actuator.
2. Fit O-rings (8d, 8f) and guide rings (8g) on upper stem (8e).
3. Fit the stem in the actuator.

5

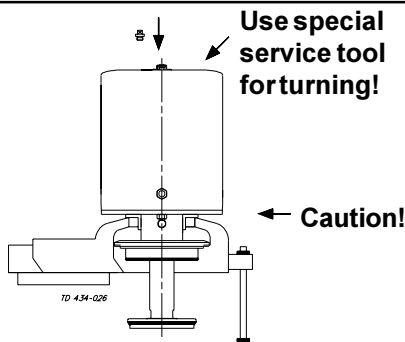

1. Fit bonnet (13) in the actuator.
2. Fit lock wire (14) and turn the actuator until the lock wire is fixed.
3. Fit air plug (25) on the actuator.

CAUTION!

Do not damage O-ring (17) when fitting the bonnet.

6

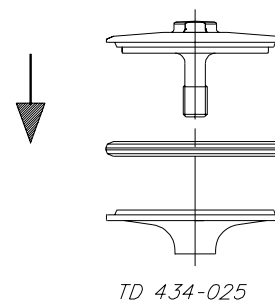

Assemble upper plug (8a, 8b, 8c).

Study the instructions carefully.
The items refer to the drawings and the parts list on pages 20-23.

Lubricate the rubber seals before fitting them.
Fitting of plug seals, please see special instructions on page 16.

3. Assembly

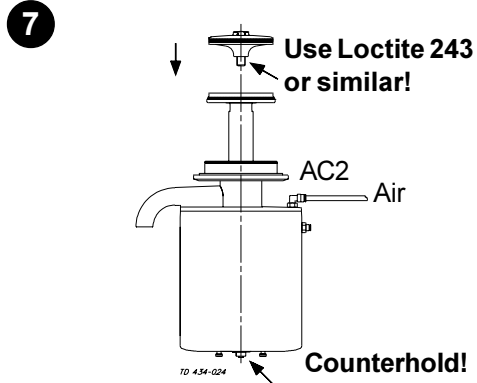

1. Supply compressed air to AC2.
2. Fit upper plug assembly (8a, 8b, 8c) on upper stem (8e) and tighten.
3. Release compressed air.

Pay special attention to the warnings!

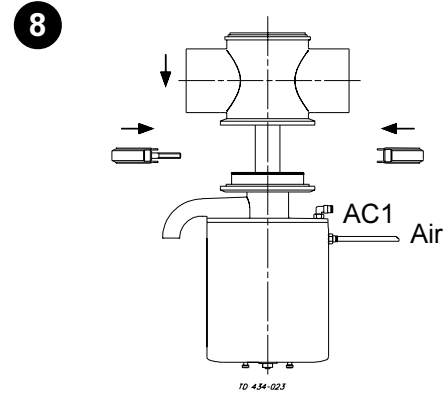

1. Supply compressed air to AC1.
2. Fit valve body (7) on bonnet (13).
3. Fit and tighten clamp (6).
4. Release compressed air.

Pay special attention to the warnings!

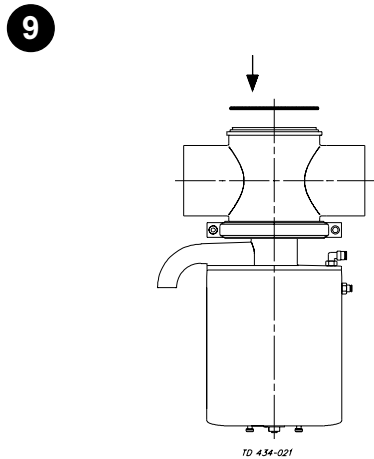

Tank flange for tank: (standard).
Fit seal ring (5) in valve body (7).

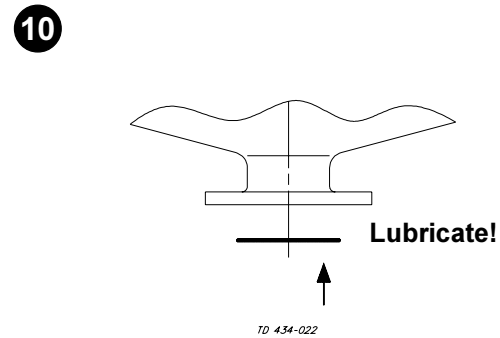

Welding flange for tube: (option)
Fit seal ring (10) in welding flange (28).

NOTE!

Lubricate the seal ring so that it remains in the welding flange.

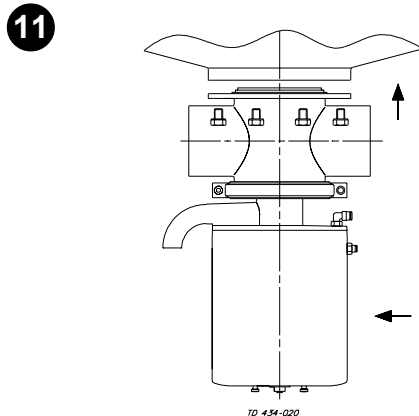

1. Fit the valve on the tank.
2. Fit counter flange (2).
3. Fit washers (3) and screws (4).
4. Tighten the screws.

Maintenance

16

Study the instructions carefully.
The items refer to the drawings and the parts list on pages 20-23.

Handle scrap correctly.

4. Replacement of plug seals (lower plug)

1

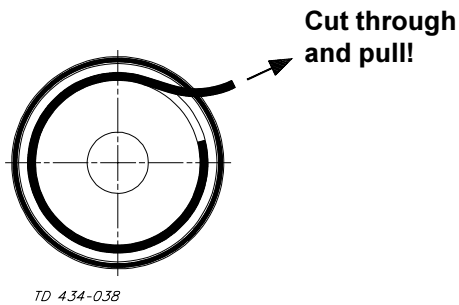

Remove the old seal rings by cutting them through and pulling them out of the grooves.

CAUTION!

Do not damage the seal ring grooves.

2

Stretch the seal ring before fitting it and turn it correctly!

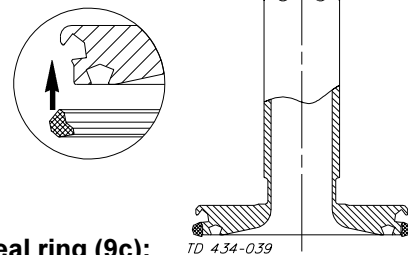

Side seal ring (9c):

Fit seal ring (9c) directly on valve plug (9).

3

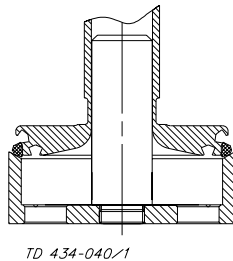

Side seal ring (9c):

Fit valve plug (9) in tool housing (4) so that seal ring (9c) is fixed on the top of the housing.

4

Use a press or similar!

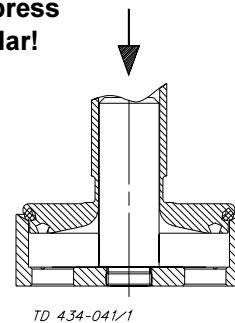

Side seal ring (9c):

Press seal ring (9c) in the groove of valve plug (9).

5

Turn the seal ring correctly!

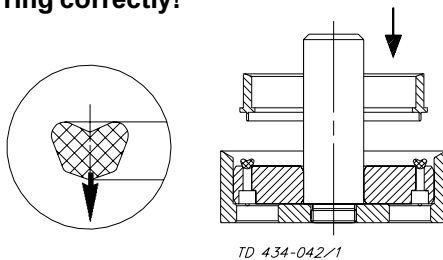

Top seal ring (9b):

1. Fit inner guide ring (2) and outer guide ring (1) in tool housing (4).
2. Place seal ring (9b) above the slot between the guide rings.
3. Fit piston ring (3) on the seal ring with the pointed end downwards.

6

Press until stop with the upper valve plug!

Press carefully to avoid damage!

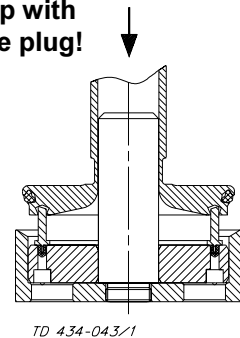

Top seal ring (9b):

Press on the top of piston ring (3) so that seal ring (9b) is pressed into the slot between outer and inner guide rings (1, 2).

CAUTION!

Do not damage the seal ring groove of the upper valve plug.

Study the instructions carefully.
The items refer to the drawings and the parts list on pages 20-27.

Handle scrap correctly.

4. Replacement of plug seals (lower plug)

7

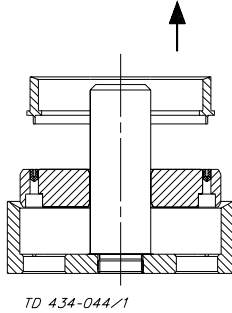

Top seal ring (9b):

1. Remove piston ring (3) from the slot between outer and inner guide rings (1, 2).
2. Remove the remaining tool parts with the fixed seal ring from tool housing (4).

8

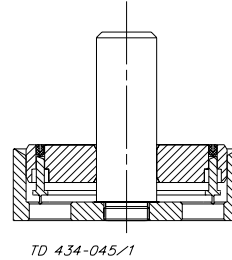

Top seal ring (9b):

1. Place piston ring (3) with the pointed end downwards in tool housing (4).
2. Place outer and inner guide rings (1, 2) with seal ring (9b) between them in the tool housing so that the piston ring enters the slot between the guide rings.

9

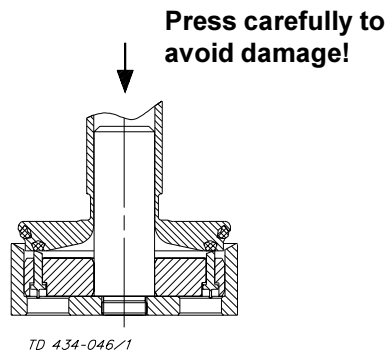

Top seal ring (9b):

Press the upper valve plug downwards against the tool so that seal ring (9b) is fixed in the groove of the valve plug.

10

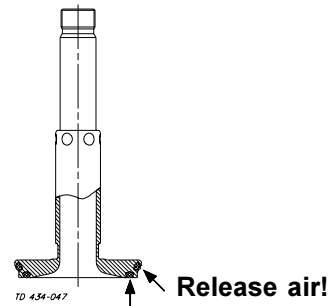

1. Ensure that seal rings (9b, 9c) are fitted correctly.
2. Release air between the seal rings and the valve plug by using a small screwdriver.

CAUTION!

Do not damage the seal rings and the seal ring grooves.

Maintenance

18

Study the instructions carefully.
The two actuator springs must be released by cutting them before scrapping the actuator.

Handle scrap correctly.

5. Scrapping of actuator

1

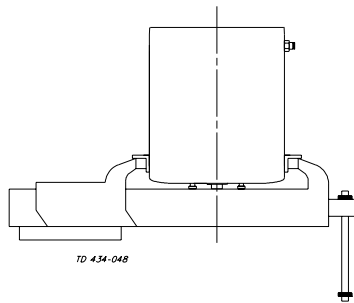

2

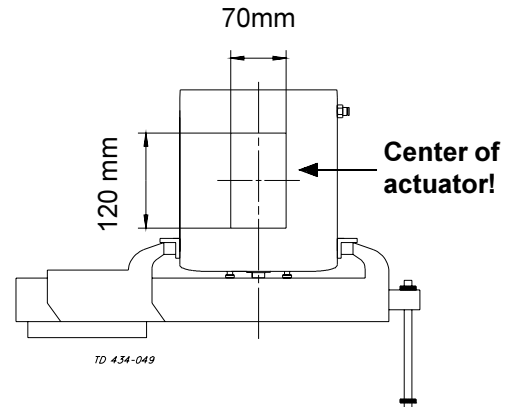

Fix the actuator properly before cutting in it.

Measure the hole to be cut in the actuator.

3

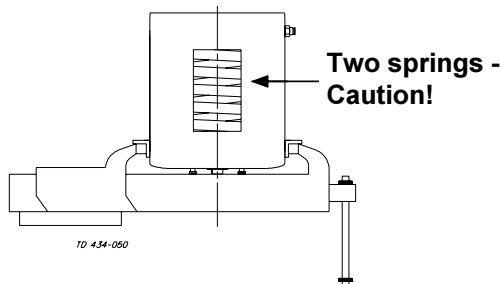

4

Cut min. 4 turns!

Cut min. 3 turns!

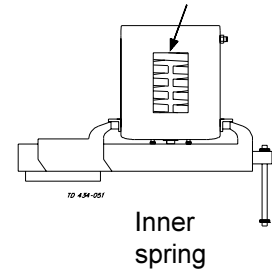
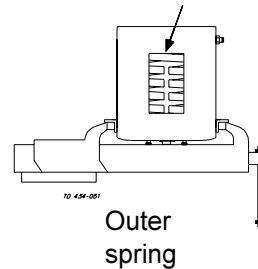

Cut the hole in the actuator so that the springs are visible.

NOTE!

It is recommended to cut by means of a hand angular grinder or by means of plasma.

1. Cut min. 4 turns of the outer spring.
2. Cut min. 3 turns of the inner spring.

NOTE!

It is recommended to cut the springs by means of torch cutting.

5

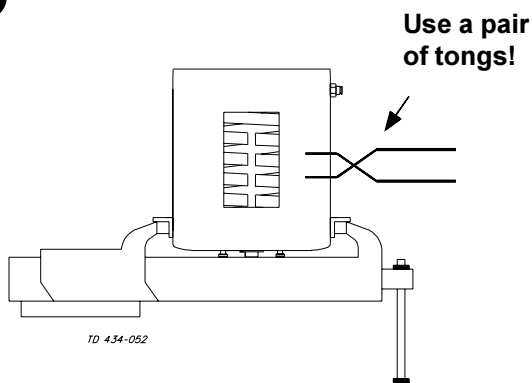

1. Check that both springs are released by means of a pair of tongs.
2. The actuator is now ready for scrapping.

It is important to observe the technical data during installation, operation and maintenance.

Inform possible personnel about the technical data.

1. Technical data

Data

Max. pressure in tank (higher pressure will open the valve) 800 kPa (8 bar)
 Min. pressure Full vacuum
 Max. pressure in the line against which the valve
 can open when pressure is 0 in the tank 8 bar (when air pressure is 7 bar)
 Temperature range -10⁰ C to +140⁰ C (EPDM)
 Air pressure, actuator 500 to 700 kPa (5 to 7 bar)

Air consumption (litre free air)	
Size	63.5 mm, 101.6 mm DN65, DN100
Lift, lower plug	0.25 x air press. (bar)
Opening	1.85 x air press. (bar)

Materials

Product wetted steel parts AISI 316L
 The welding flanges are supplied with TÜV approval and inspection certificate 3.1 B according to EN 10204
 Other steel parts AISI 304
 Product wetted seals EPDM (standard)
 Other seals Nitrile (NBR)
 Alternative product wetted seals Nitrile (NBR) and fluorinated rubber (FPM)
 Finish Semi bright

Drawing/Parts list

The drawing and the parts list include all items.

The items are identical with the items in the Spare Parts List.

When ordering spare parts, please use the Spare Parts List!

Parts list SMP-TO

20

Item	Qty.	Denomination
1	1	Tank flange
2	2	Counter flange
3	8	Screw
4	8	Washer
5Δ	1	O-ring
6	1	Clamp, complete
7	1	Valve body
8	1	Upper plug complete
8a	1	Upper plug, upper part
8bΔ	1	Seal ring
8c	1	Upper plug, lower part
8dΔ	1	O-ring
8e	1	Upper stem
8fΔ	1	O-ring
8gΔ	2	Guide ring
9	1	Lower plug complete
9a	1	Lower plug
9bΔ	1	Seal ring
9cΔ	1	Seal ring
10Δ	1	O-ring
10□	1	O-ring
11Δ	1	Lip seal
12	1	Air fitting
13	1	Bonnet
14	1	Lock wire
15Δ	1	O-ring
16Δ	1	Guide ring
17Δ	1	O-ring
18Δ	1	O-ring
19	1	Upper piston
20Δ	1	O-ring
21	1	Support ring
22	1	Sprin assembly
23	1	Actuator complete
24	1	Air fitting
25	1	Air plug
26□	6	Nut
27□	6	Washer
28□	1	Welding flange
29□	2	Counter flange
30□	6	Washer
31□	6	Screw

□: Alternative for welding flange

Δ: Service kit - EPDM, NBR, FPM
(See Spare Parts List)

This page shows an exploded drawing of SMP-TO.

The drawing includes all items of the valve.
They are identical with the items in the Spare Parts List

Exploded drawing

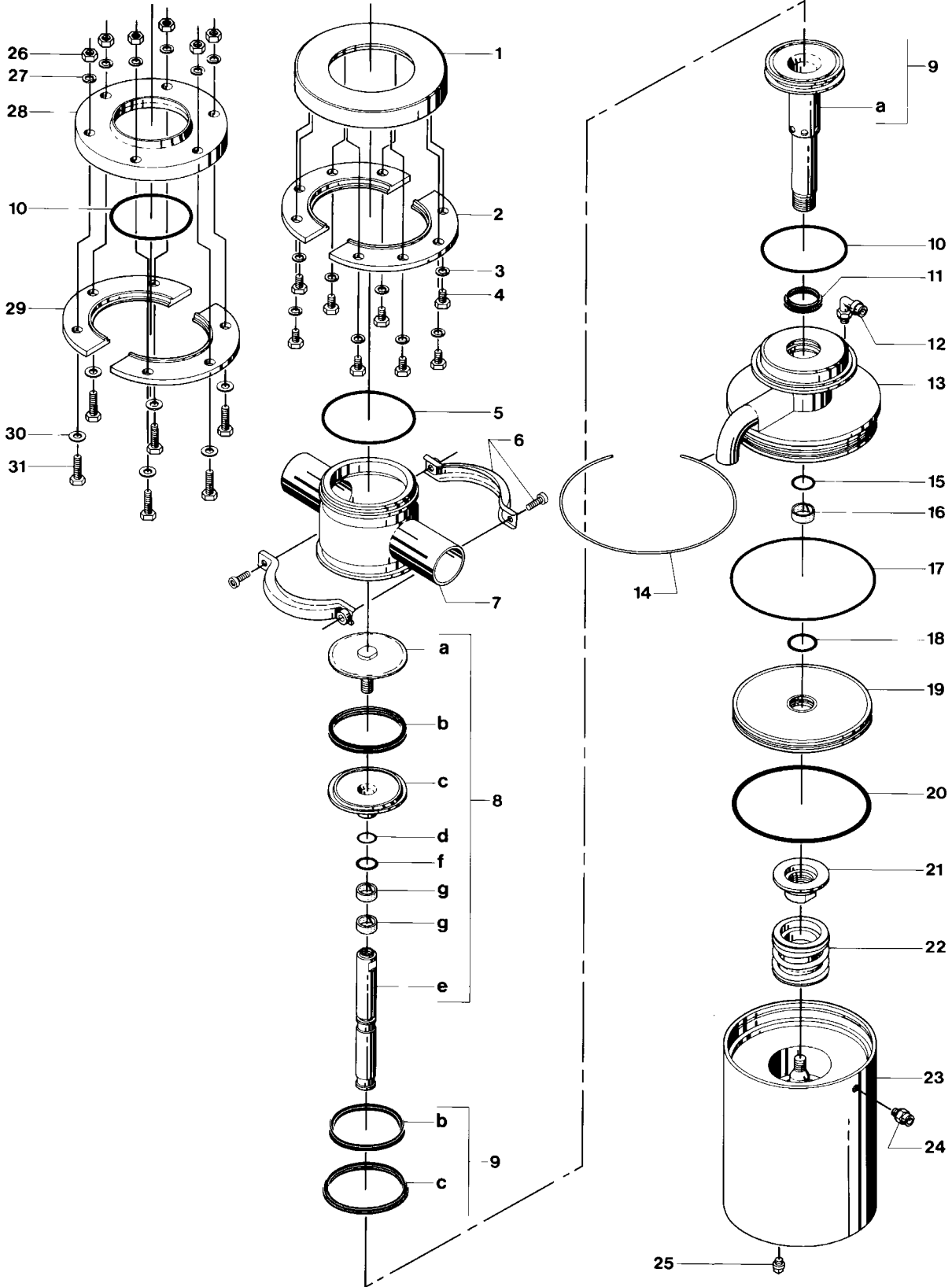

Drawing/Parts list

The drawing and the parts list include all items.

The items are identical with the items in the Spare Parts List.

When ordering spare parts, please use the Spare Parts List!

Parts list SMP-TO

22

Item	Qty.	Denomination
1	1	Tank flange
2	2	Counter flange
3	8	Screw
4	8	Washer
5Δ	1	O-ring
6	1	Clamp, complete
7	1	Valve body
8	1	Upper plug complete
8a	1	Upper plug, upper part
8bΔ	1	Seal ring
8c	1	Upper plug, lower part
8dΔ	1	O-ring
8e	1	Upper stem
8fΔ	1	O-ring
8gΔ	2	Guide ring
9	1	Lower plug complete
9a	1	Lower plug
9bΔ	1	Seal ring
9cΔ	1	Seal ring
10Δ	1	O-ring
10□	1	O-ring
11Δ	1	Lip seal
12	1	Air fitting
13	1	Bonnet
14	1	Lock wire
15Δ	1	O-ring
16Δ	1	Guide ring
17Δ	1	O-ring
18Δ	1	O-ring
19	1	Upper piston
20Δ	1	O-ring
21	1	Support ring
22	1	Sprin assembly
23	1	Actuator complete
24	1	Air fitting
25	1	Air plug
26□	6	Nut
27□	6	Washer
28□	1	Welding flange
29□	2	Counter flange
30□	6	Washer
31□	6	Screw

□: Alternative for welding flange

Δ: Service kit - EPDM, NBR, FPM
(See Spare Parts List)

The drawings below shows SMP-TO.

The items refer to the parts list on the opposite part of the page.

Drawings

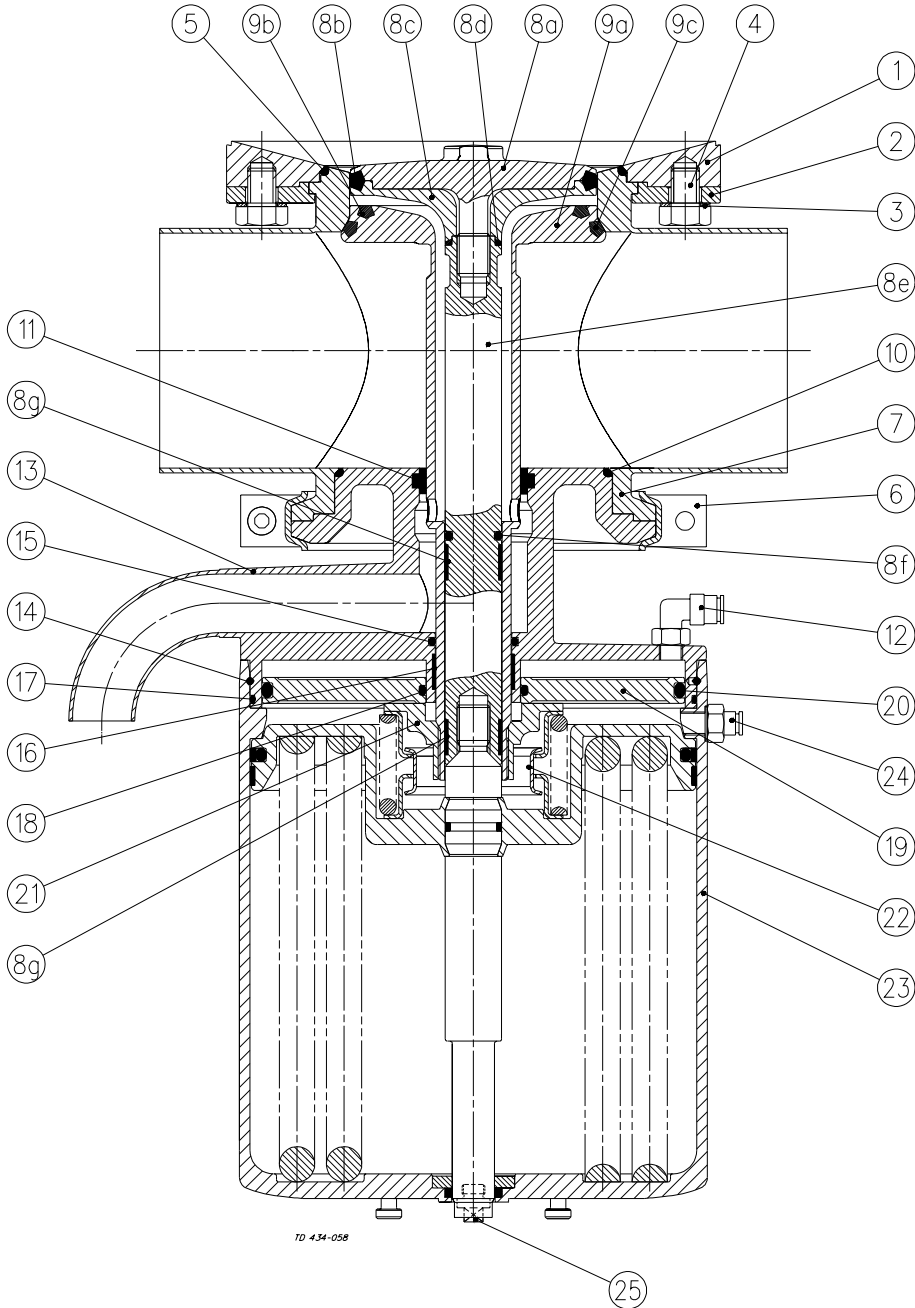

TD 434-058

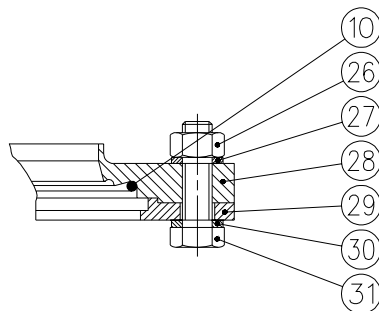

**Welding flange for stub tube (□)
(option)**

Drawing/Parts List

The drawing and the parts list include all items.

*The items are identical with the items in the Spare Parts List.
When ordering spare parts, please use the Spare Parts List!*

Parts List Tool for SMP-TO

24

Item	Qty.	Denomination
1	1	Outer guide ring
2	1	Inner guide ring
3	1	Piston ring
4	1	Spindle
5	1	Tool housing

(See Spare Parts List)

This page shows an exploded drawing of the tool for the SMP-TO.

The drawing includes all items of the tool. They are identical with the items in the Spare Parts List.

Exploded drawing

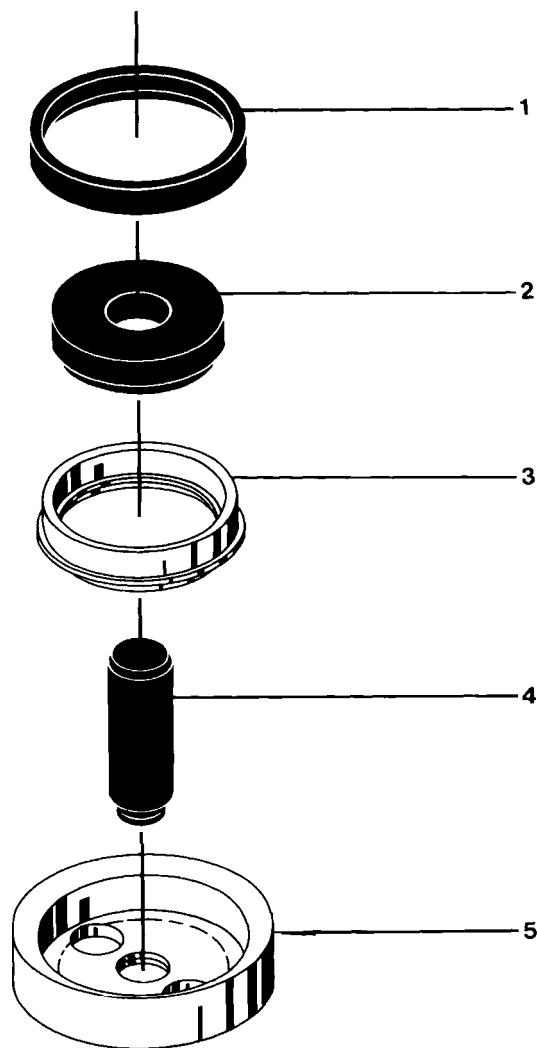

Drawing/Parts List

The drawing and the parts list include all items.

The items are identical with the items in the Spare Parts List.

When ordering spare parts, please use the Spare Parts List!

Parts List Tool for SMP-TO

26

Item	Qty.	Denomination
1	1	Outer guide ring
2	1	Inner guide ring
3	1	Piston ring
4	1	Spindle
5	1	Tool housing

(See Spare Parts List)

The drawing below shows the tool for the SMP-TO.

The items refer to the parts list on the opposite part of the page.

Drawing

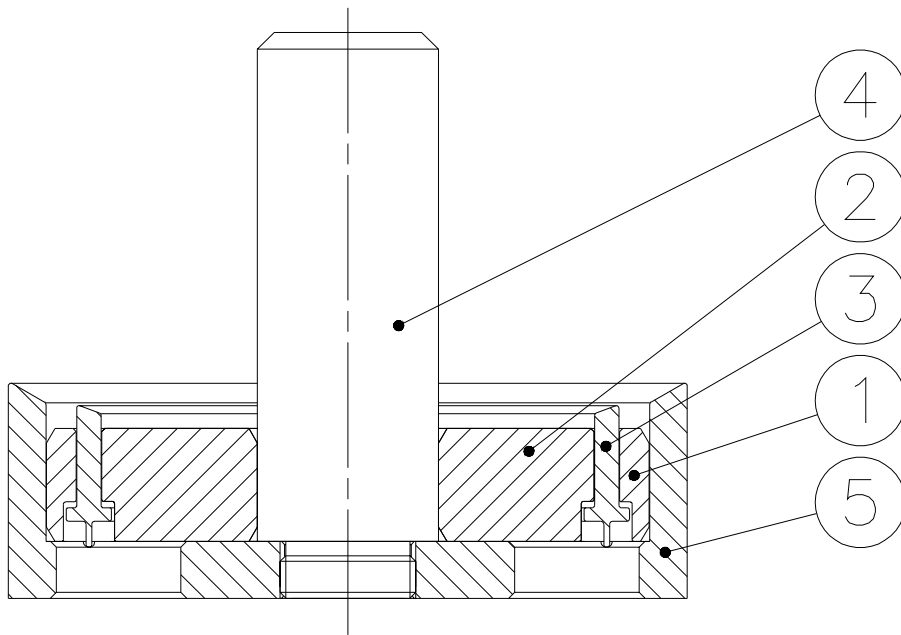

TD 434-059/2

How to contact Alfa Laval

Contact details for all countries are continually updated on our website.

Please visit www.alfalaval.com to access the information direct.