

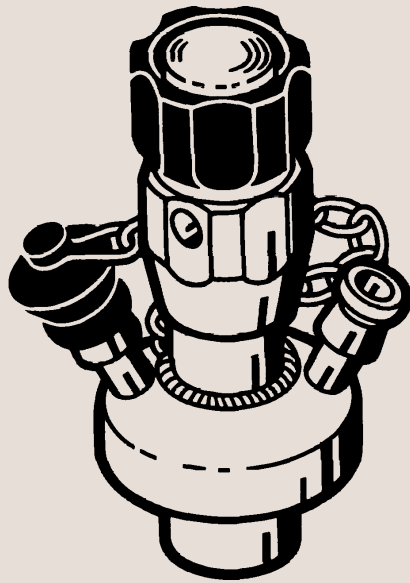

Instruction Manual

Keofitt Aseptic Membrane Sampling Valve



IM70783-GB2 1996-06

Table of contents

This manual is divided into main sections. - See below.

Safety

1. Important information	2
2. Warning signs	2
3. Safety precautions	3

Installation

1. Unpacking/delivery	4
2. General installation	5
3. Welding	6

Operation

1. General operation	7
2. Sampling/sterilization with alcohol	8
3. Sampling/sterilization w. steam generator ...	9
4. Sampling/sterilization accessories	10

Maintenance

1. General maintenance	11
2. Dismantling	12
3. Assembly	13

Technical data

1. Technical data	14
-------------------------	----

Drawings/Parts list

1. Exploded drawing	16
2. Drawing/Parts list	17

Appendix

Spareparts

Safety

Unsafe practices and other important information are emphasized in this manual.

Warnings are emphasized by means of special signs.

1. Important information

Always read the manual before using the valve!

2

- WARNING!** : Indicates that special procedures **must** be followed to avoid severe personal injury.
- CAUTION!** : Indicates that special procedures **must** be followed to avoid damage to the valve.
- NOTE!** : Indicates important information to simplify practices or to make them clearer.

2. Warning signs



: General warning.



: Caustic agents.

All warnings in the manual are summarized on this page.

Pay special attention to the instructions below so that severe personal injury or damage to the valve are avoided.

3. Safety precautions

Installation:



- : - **Always** read the technical data thoroughly (see page 14).
- **Always** release compressed air after use (automatic valve).

Operation:



- : - **Always** read the technical data thoroughly (see page 14).
- **Always** release compressed air after use (automatic valve).



- : **Never** touch the valve body or the tank/pipelines when sampling or sterilizing.



- : **Never** touch the liquids from sampling or sterilization when they are discharged from the valve.

Maintenance:



- : - **Always** read the technical data thoroughly (see page 14).
- **Always** release compressed air after use (automatic valve).



- : - **Never** service the valve when it is hot.
- **Never** service the valve with valve and tank/pipelines under pressure.

Installation

The instruction manual is part of the delivery.
Study the instructions carefully.

The valve consists of valve body and valve head.
Valve body: 4 different installation parts.
Valve head: 4 different operating parts.

1. Unpacking/Delivery

1

CAUTION!

We cannot be held responsible for incorrect unpacking.

Check the delivery for:

1. Complete valve, manual or automatic (see 2-5).
2. Delivery note.
3. Instruction manual.

2

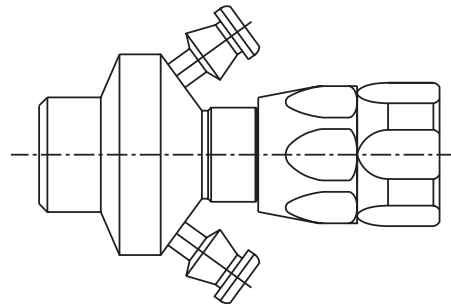

Adjustable manual operation:

1. Shown with welding end for tank.
2. Can be supplied with all other valve bodies.

3

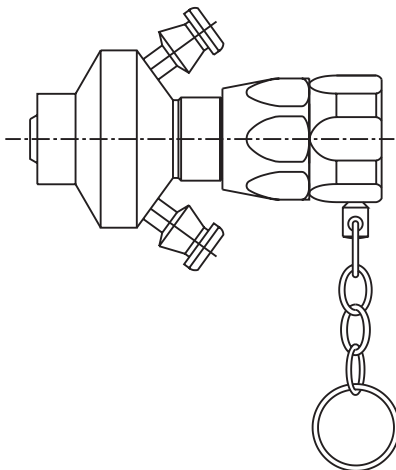

Adjustable manual operation (with key):

1. Shown with welding end for tube.
2. Can be supplied with all other valve bodies.

4

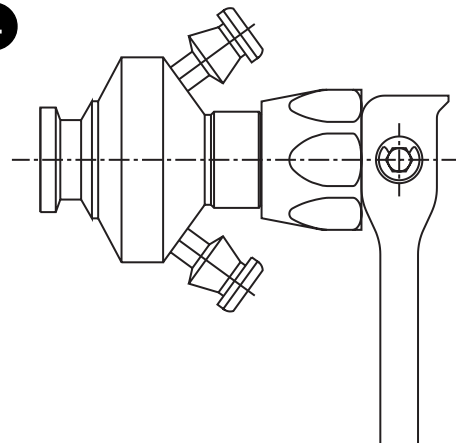

Non-adjustable on/off operation:

1. Shown with clamp connection.
2. Can be supplied with all other valve bodies.

5

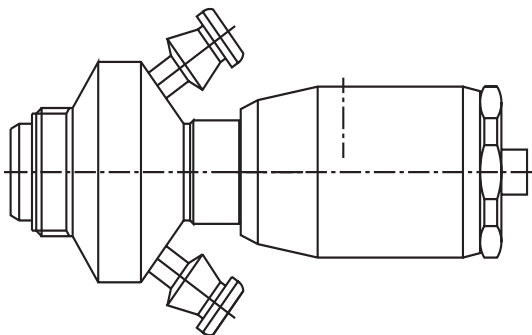

Non-adjustable pneumatic operation:

1. Shown with thread for fitting in a socket.
2. Can be supplied with all other valve bodies.

6

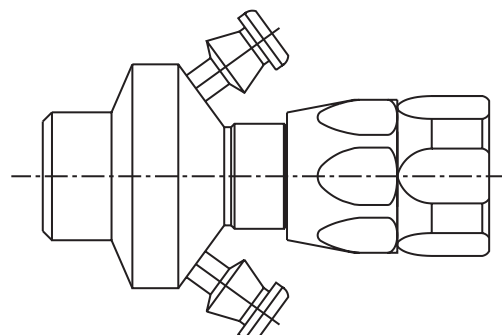

Manual/automatic valve:

1. Inspect the valve for visible transport damages.
2. Avoid damaging the valve when unpacking.

Study the instructions carefully and pay special attention to the warnings.

The valve is supplied with either welding end, with clamp or with male thread.

2. General installation

1

- **Always** read the technical data thoroughly (see page 14).
- **Always** release compressed air after use (automatic valve).

CAUTION!

We cannot be held responsible for incorrect installation.

2

Must be vertically positioned!

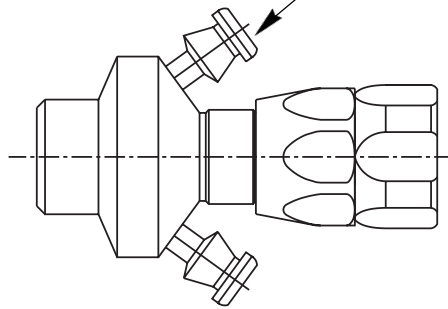

Always install the valve horizontally and the hose connections vertically.

3

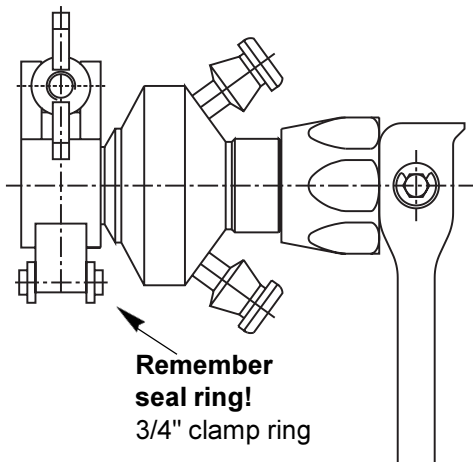

Clamp connection:

Ensure that the connection is tight.

4

M 28 x 1,5

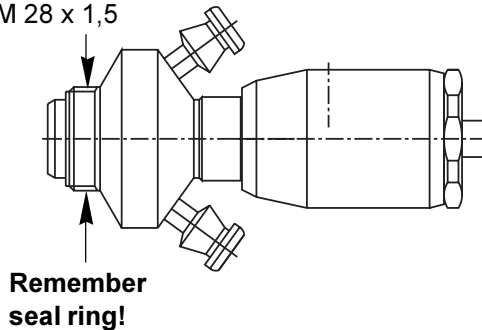

Male thread/socket:

Ensure that the connection is tight.

5

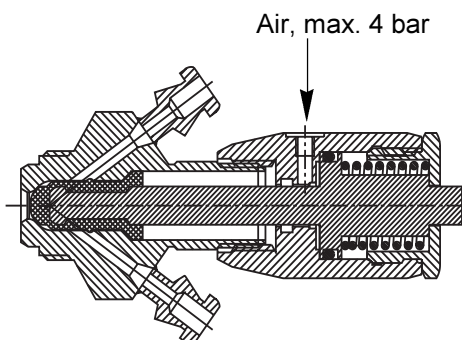

Air connection: (Automatic valve).
Connect compressed air correctly.

6

ISO female cone
Connect correctly!

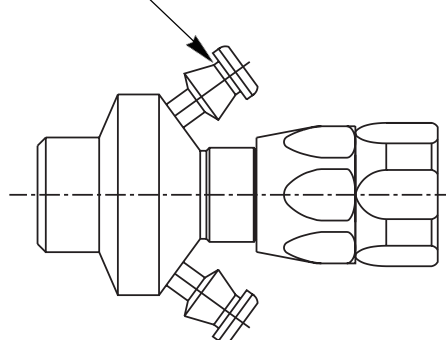

Sampling/sterilizing:

1. See the description of sampling/sterilization and optional extras on the pages 8-10.
2. Connect tubes for sampling/sterilization correctly (automatic valve).

Installation

Study the instructions carefully
Weld carefully.

3. Welding

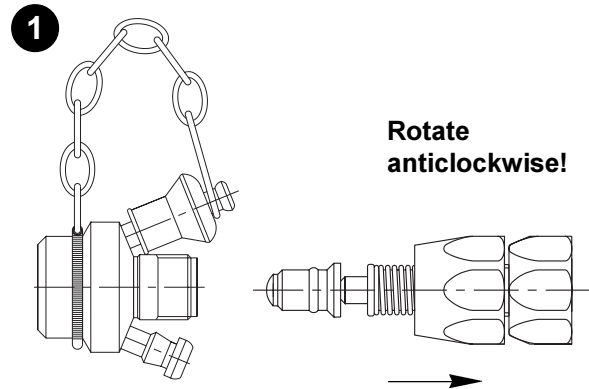

1. Remove valve head (5) from valve body (1).
2. If supplied, remove the pneumatic valve head in the same way.

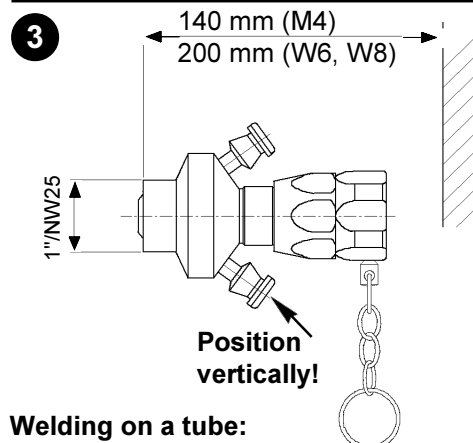

Welding on a tube:

1. Weld the valve body horizontally on the tube.
2. Maintain the minimum clearance so that the valve head can be removed.

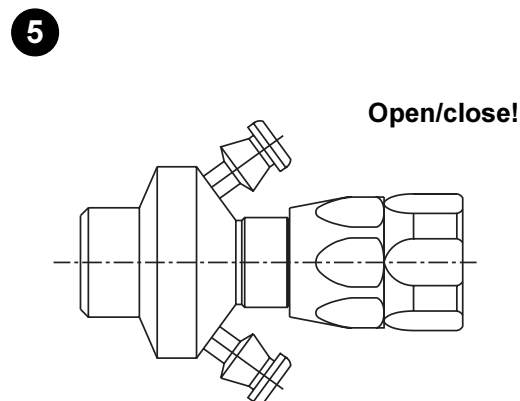

Pre-use check - Manual valve:

Open and close the valve a few times to ensure that it operates smoothly.

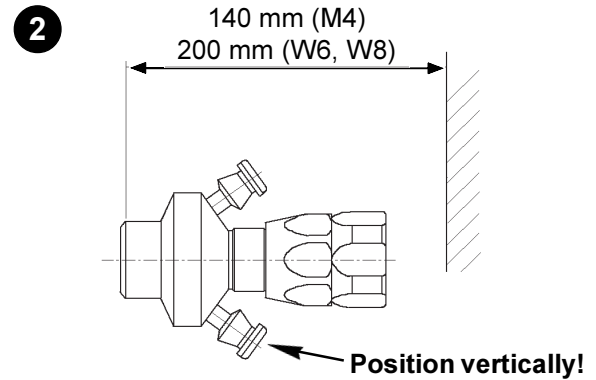

Welding on a tank:

1. Weld the valve body horizontally on the tank.
2. Maintain the minimum clearance so that the valve head can be removed.

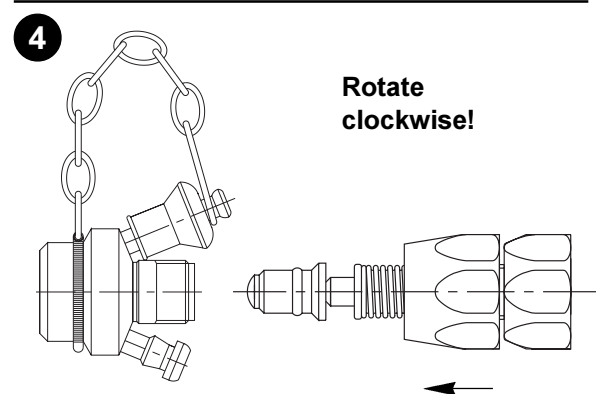

1. Fit valve head (5) in valve body (1) and tighten firmly.
2. If supplied, fit the pneumatic valve head in the same way.

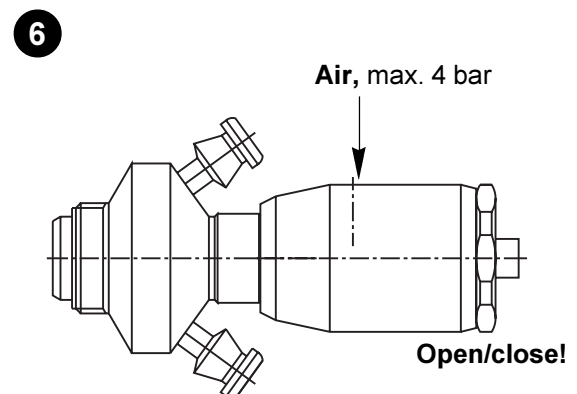

Pre-use check - Automatic valve:

1. Supply compressed air to the valve.
2. Open and close the valve a few times to ensure that it operates smoothly.

Pay special attention to the warning!

Study the instructions carefully and pay special attention to the warnings!

The valve operation is either adjustable or non-adjustable and is carried out by means of 4 different valve heads.

1. General operation

1

- ⚠ - **Always** read the technical data thoroughly (see page 14).
- **Always** release compressed air after use (automatic valve).

CAUTION!

We cannot be held responsible for incorrect operation.

2

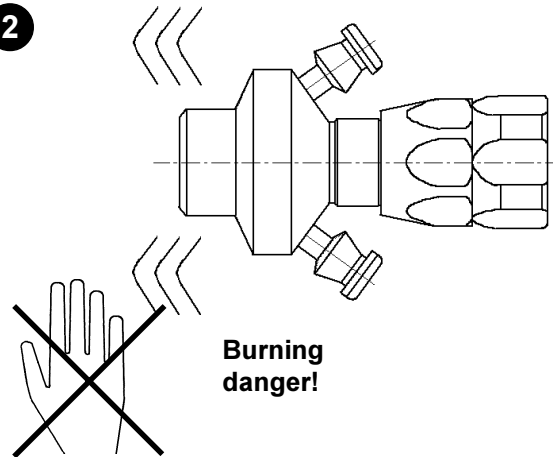

- ⚠ **Never** touch the valve body or the tank/ pipelines when sampling or sterilizing.

3

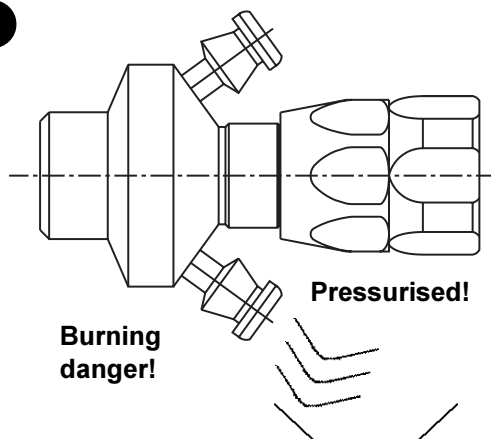

- ⚠ **Never** touch the liquids from sampling or sterilization when they are discharged from the valve.

4

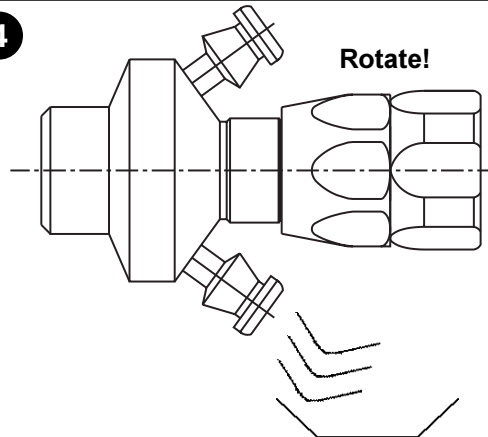

Adjustable manual operation:

1. Release the key, if fitted.
2. Rotate the finger grip clockwise to carry out sampling.

5

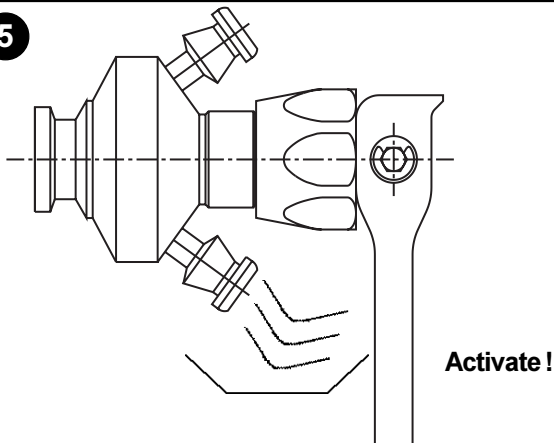

Non-adjustable on/off operation:
Activate the lever to carry out sampling.

6

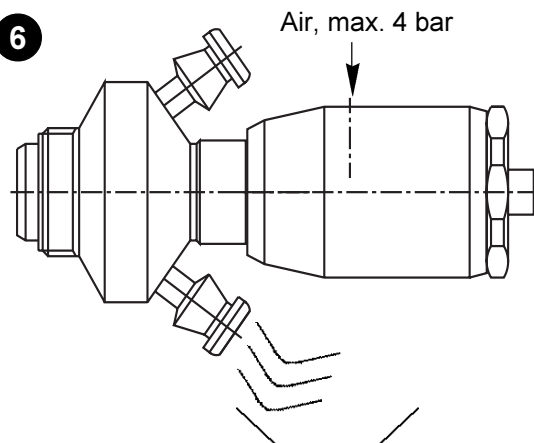

Non-adjustable pneumatic operation:

Supply compressed air to the valve to carry out sampling.

Pay special attention to the warnings!

Operation

Study the instructions carefully.
Sterilize the valve with alcohol or steam after sampling.

Alcohol: 70% alcohol.

2. Sampling/sterilization with alcohol

1

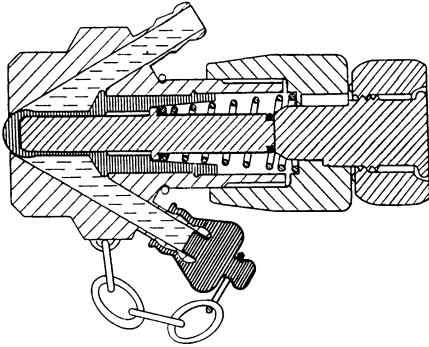

1. Close the lower hose connection of the valve.
2. Fill the valve with alcohol.
3. The valve is now ready for sampling.

2

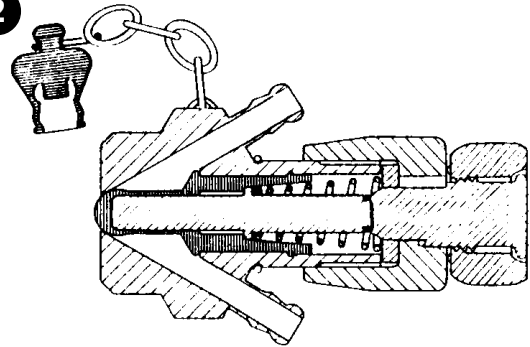

1. Remove the rubber cap.
2. Let the valve drain.

NOTE!

If using a Steam Generator, the interior of the valve should be sterilized for approx. 40 seconds.

3

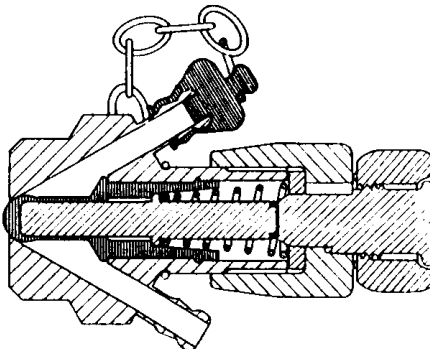

Close the upper hose connection with the rubber cap.

4

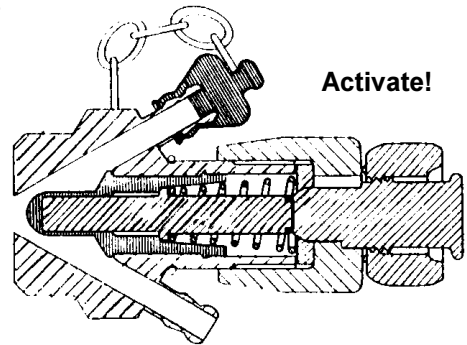

Open the valve to carry out sampling:

- Rotate the finger grip on the adjustable valve clockwise.
- Activate the lever on the on/off valve.
- Supply compressed air to the pneumatic valve.

5

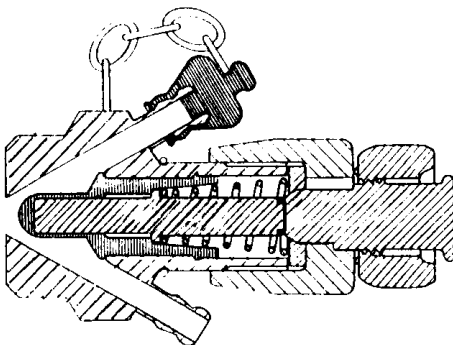

Carry out the sampling (see sampling accessories on page 10).

6

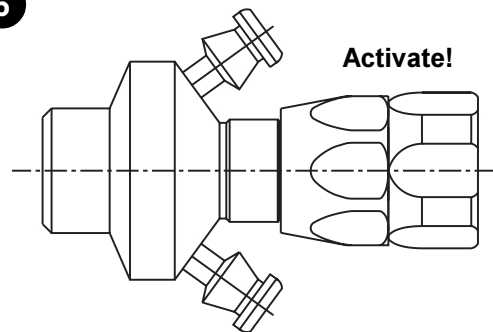

Close the valve after sampling:

- Rotate the finger grip on the adjustable valve anticlockwise.
- Deactivate the lever on the on/off valve.
- Release the air pressure on the pneumatic valve.

Study the instructions carefully.
Alcohol: 70% alcohol.

Sampling and sterilization can be carried out by means of various accessories (see page 10).

2. Sampling/Sterilization with alcohol

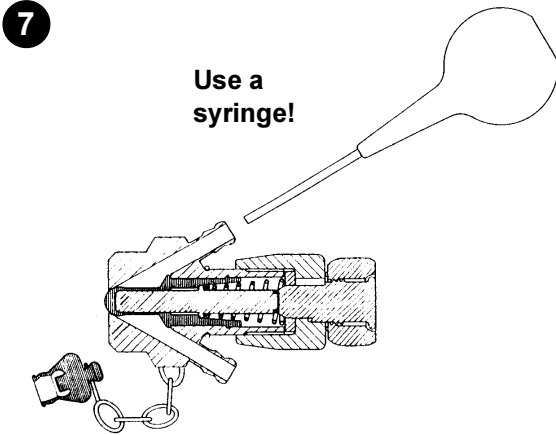

1. Remove the cap.
2. Rinse with water or alcohol by using a syringe.

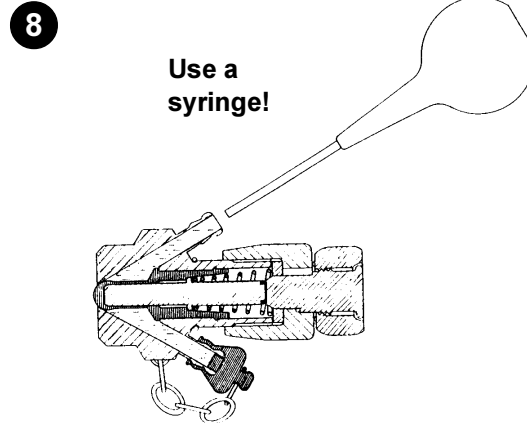

1. Replace the rubber cap and fit it on the lower hose connection.
2. Fill the valve with alcohol.
3. The valve is now ready for the next sampling.

3. Sampling/sterilization with Steam Generator

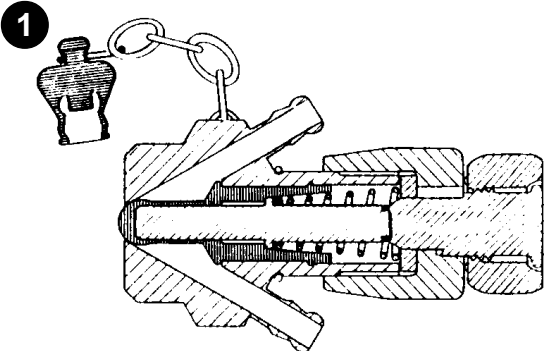

1. Keep both hose connections open for ventilation.
2. Steam sterilize the valve for approx. 40 seconds (see sterilization accessories on page 10).

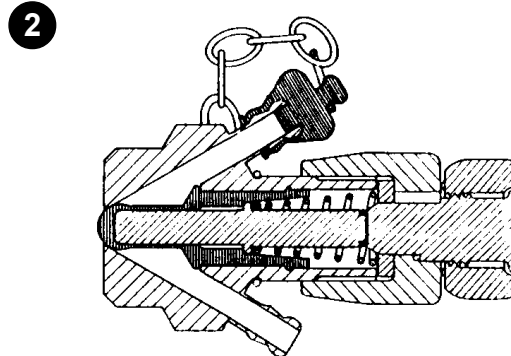

Close the upper hose connection with a sterile rubber cap.

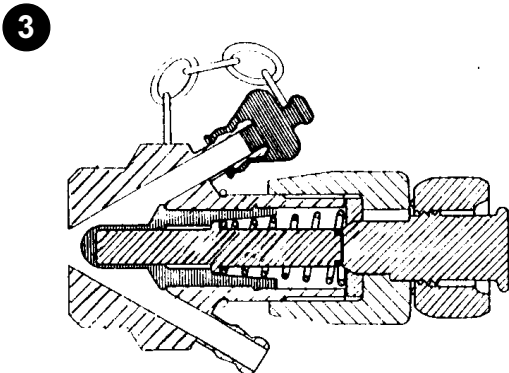

1. Carry out the sampling (see sampling accessories on page 10).
2. Remove the rubber cap, sterilize it or replace it.

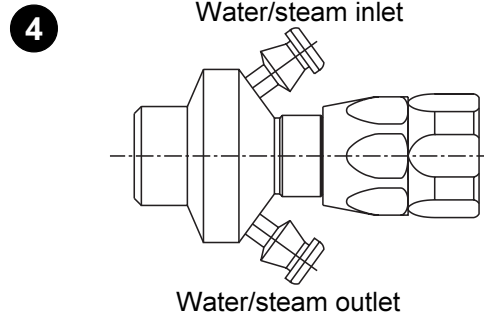

1. Rinse the valve with water and steam sterilize it (see sterilization accessories on page 10).
2. Keep the hose connections open until the next sampling.

NOTE!

Heat accumulated during steaming will dry out completely the interior of the valve.

Operation

10

Sampling and sterilization can be carried out by means of various accessories.

Study the instructions carefully.

4. Sampling/Sterilization accessories (optional extras)

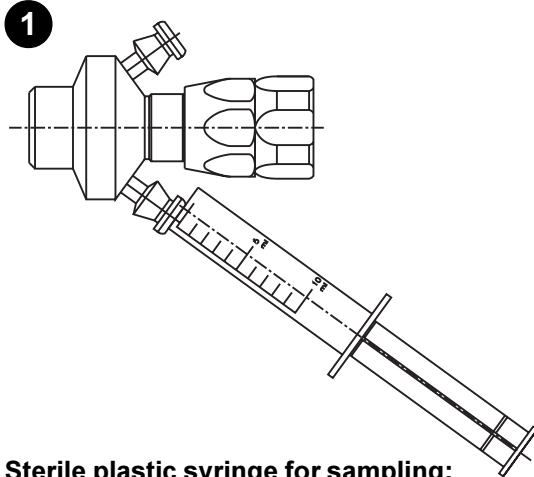

Sterile plastic syringe for sampling:

The syringe has ISO male cone so that it is easy to draw samples into it.

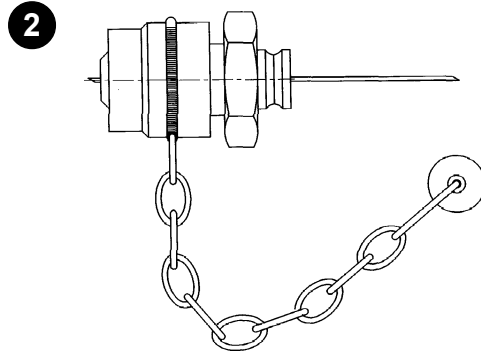

Micro port for micro biological sampling:

1. Fit the Keofitt Hypodermic Needle through the hole (micro port) to carry out sampling.
2. Keep the micro port sterile by means of a Keofitt wick which is inserted in the port.

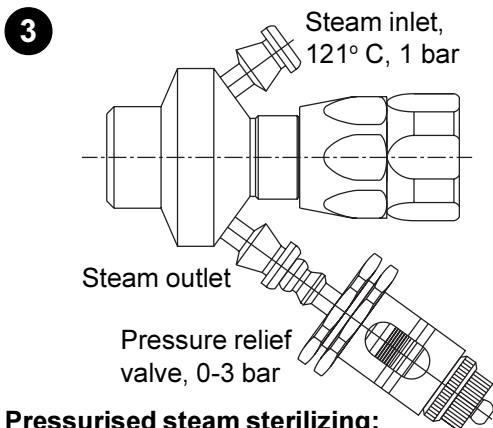

Pressurised steam sterilizing:

1. The pressure relief valve is preset at 1 bar for sterilization at 121° C.
2. The pressure relief valve can be set for different pressures up to 3 bar (=143°C).

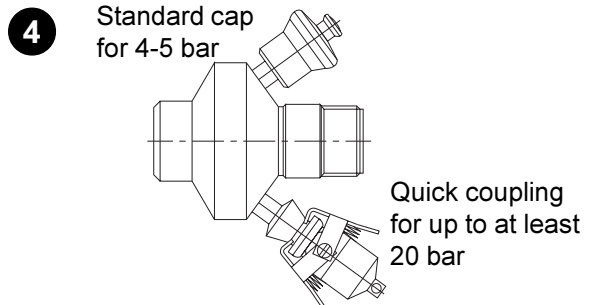

Quick coupling for hose connections:

The standard rubber cap can be replaced by a stainless steel quick coupling to withstand higher pressures.

- Quick coupling for stainless steel plug.
- Quick coupling for teflon/stainless steel tube.
- Quick coupling for silicone tube.

Maintain the valve carefully.
Study the instructions carefully and pay special attention to the warnings!

Always keep spare membranes and rubber caps in stock.

1. General maintenance

1



- **Always** read the technical data thoroughly (see page 14).
- **Always** release compressed air after use (automatic valve).

CAUTION!

All scrap must be stored/discharged in accordance with current rules/directives.

2

Atmospheric pressure required!

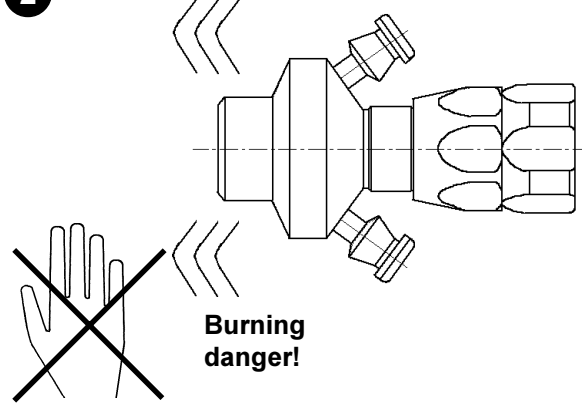

- **Never** service the valve when it is hot.
- **Never** service the valve with valve and tank/pipelines under pressure.

Ordering spare parts

- Contact the Sales Department.
- Order from the Spare Parts List.

	Membrane	Rubber cap
Preventive maintenance	Replace every second month	Replace after six months
Maintenance after leakage (leakage normally starts slowly)	Replace at the end of the day	
Planned maintenance	<ul style="list-style-type: none"> - Regular inspection for leakage and smooth operation - Keep a record of the valve - Use the statistics for planning of inspections Replace after leakage	Replace, if necessary

Maintenance

12

Study the instructions carefully.
The items refer to the drawings and the parts list on the pages 16-17.

Handle scrap correctly.

2. Dismantling

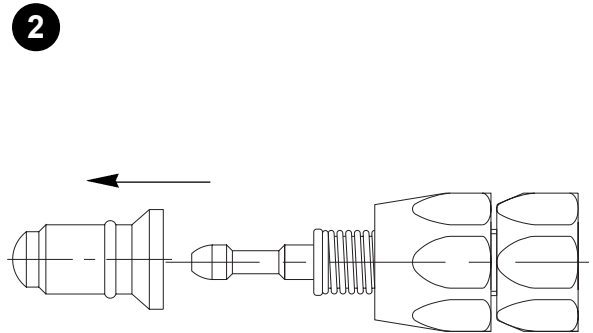
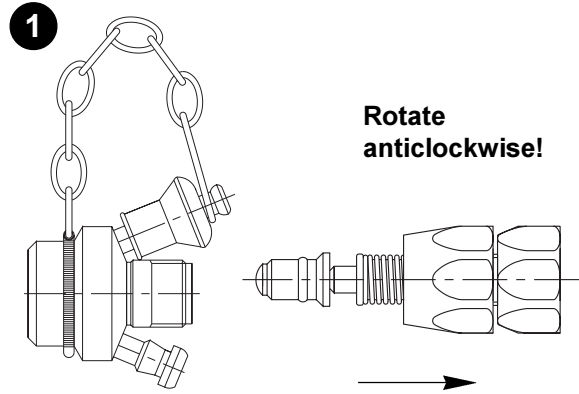

1. Remove valve head (5) from valve body (1).
2. If supplied, remove the pneumatic valve head in the same way.

Remove membrane (4) from valve head (5).

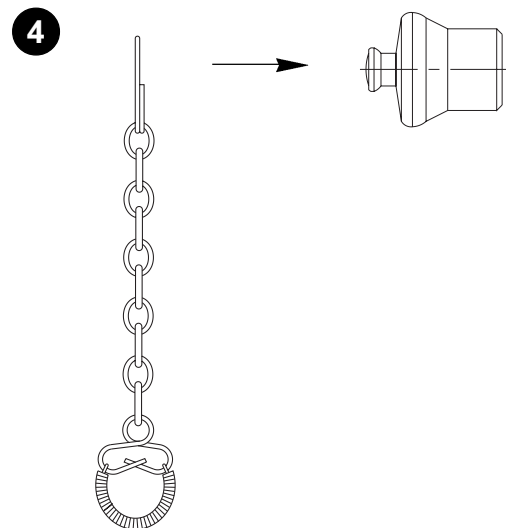
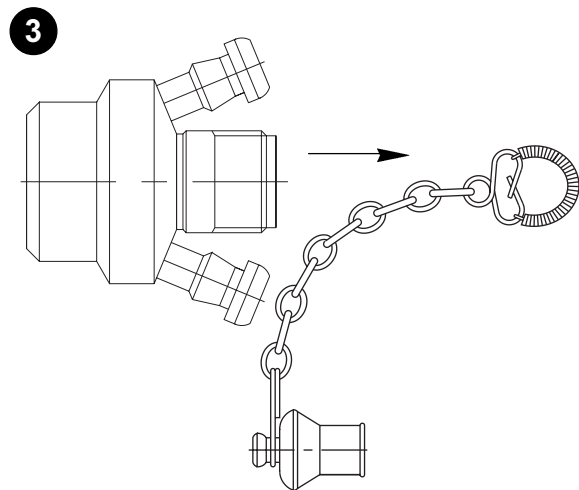

Remove chain (3) together with rubber cap (2) from valve body (1).

Remove rubber cap (2) from chain (3).

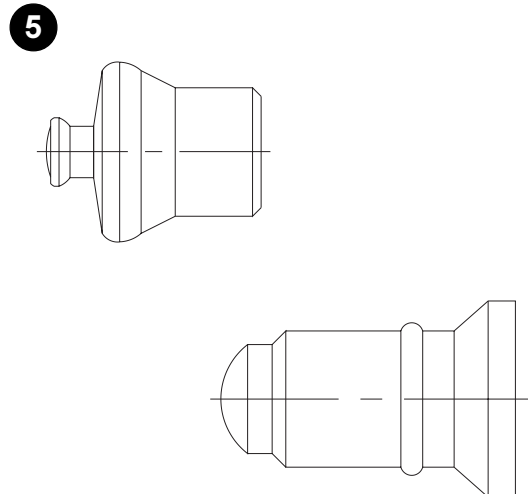

Replace rubber cap (2) and membrane (4).

Study the instructions carefully.
The items refer to the drawings and the parts list on the pages 16-17.

3. Assembly

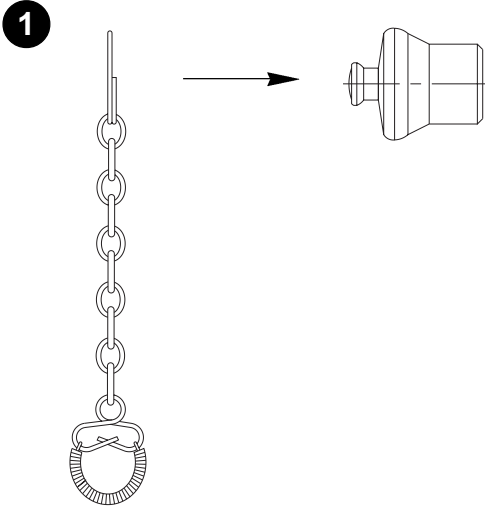

Fit chain (3) on rubber cap (2).

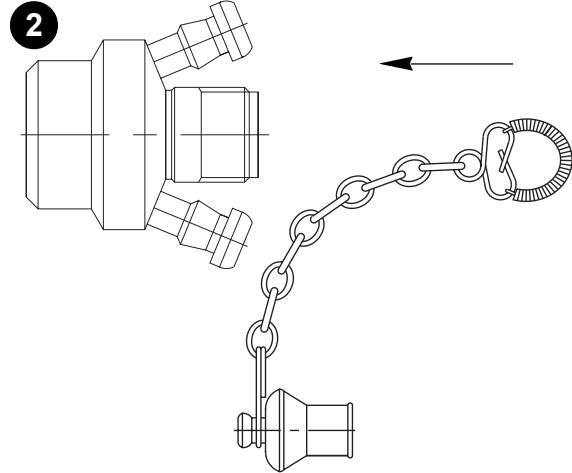

Fit chain (3) together with rubber cap (2) on valve body (1).

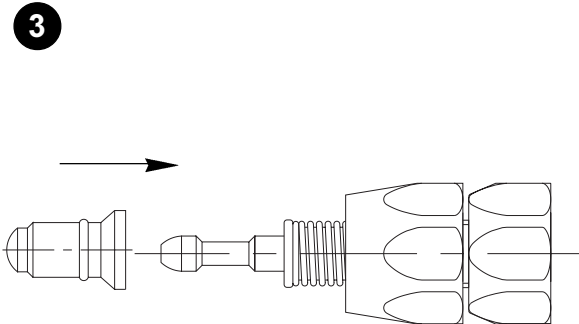

Fit membrane (4) on valve head (5).

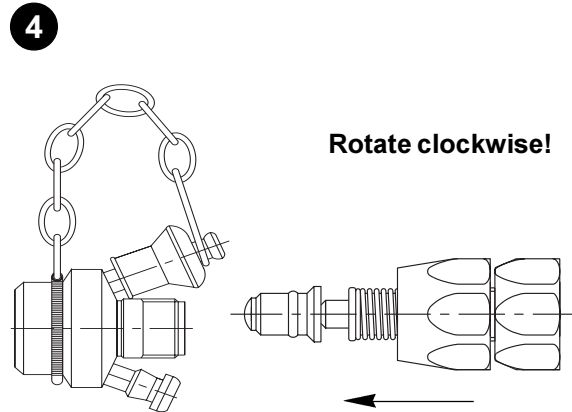

1. Fit valve head (5) in valve body (1) and tighten firmly.
2. If supplied, fit the pneumatic valve head in the same way.

Pre-use check:

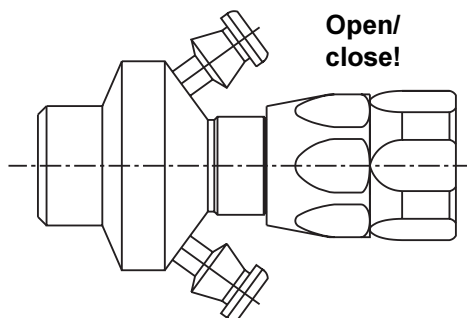

Manual valve:

Open and close the valve a few times to ensure that it operates smoothly.

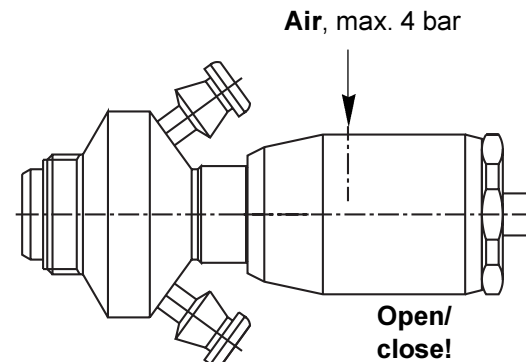

Automatic valve:

1. Supply compressed air to the valve.
2. Open and close the valve several times to ensure that it operates smoothly.

Pay special attention to the warnings!

Technical data

It is important to observe the technical data during installation, operation and maintenance.

Inform possible personnel about the technical data.

1. Technical data

Data

Max. working pressure 1000kPa (10 bar)

Max. temperature

- EPDM membrane 140°C

- Silicone membrane 180°C

Max. air pressure (automatic valve) 400kPa (4 bar)

Materials

Product wetted steel parts AISI 316L

Other steel parts AISI 304

Membrane EPDM or Silicone

Rubber cap Silicone



Exploded drawing

This page shows an exploded drawing of Keofitt aseptic membrane sampling valve.

The drawing includes all items of the valve. They are identical with the items in the Spare Parts List.

Keofitt aseptic membrane sampling valve

16

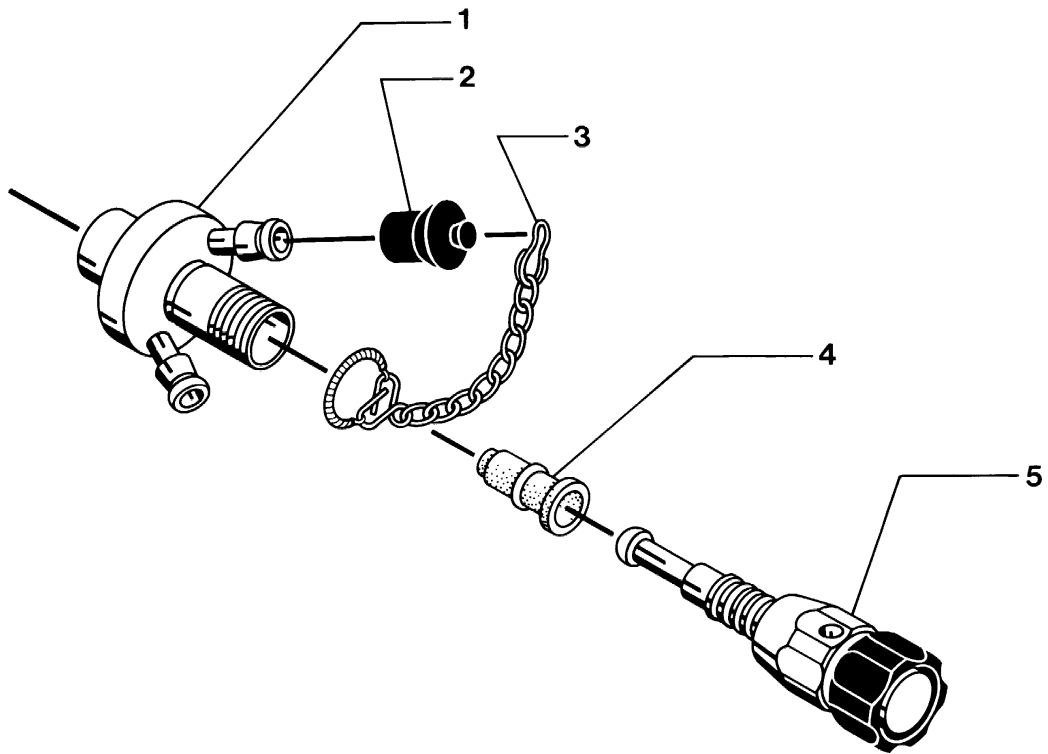

The drawing and the parts list include all items.
The items are identical with the items in the Spare
Parts List.

When ordering spare parts, please use the Spare
Parts List!

Parts list

Keofitt aseptic membrane sampling valve

Item	Qty.	Denomination
1	1	Valve body
2	1	Rubber cap
3	1	Chain with hook
4	1	Membrane
5	1	Valve head

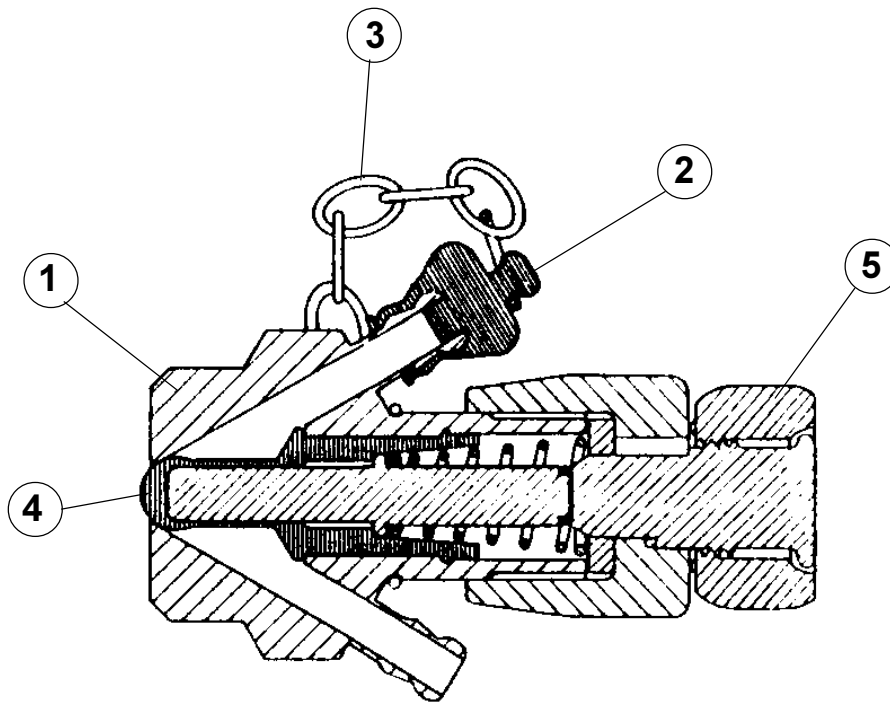

How to contact Alfa Laval

Contact details for all countries are continually updated on our website. Please visit www.alfalaval.com to access the information direct.