

One Valve for All Solutions

Unique PMO Mixproof Valve Meets PMO Requirements

Concept

This PMO Mixproof valve is based on the proven and exceptionally flexible design of the Unique Mixproof valves from Alfa Laval. It meets the criteria of the PMO (Pasteurized Milk Ordinance) standards which state that both valve seats must be position detectable, as well as the leakage chamber must have the same area as the process pipe connection. Finally, the actuator is fail safe by spring to close.

Working Principle

Unique is remote-controlled by means of compressed air. The valve is a normally closed (NC) valve. The valve has two independent plug seals, forming a leakage chamber between them under atmospheric pressure during every working condition. In case of rare accidental leaking of product, this will flow into the leakage chamber and be discharged through the leakage outlet. When the valve is open, the leakage chamber is closed. The product can then flow from one line to the other. There is virtually no spillage of product when operating the valve.

This PMO version of the Unique Mixproof valve is a high-end valve with regards to process security as well as from a hygienic point of view. The valve plugs are always balanced in both upper and lower valve body. Assuring no sensitivity to pressure spikes.

All of the seat movements are detectable by ThinkTop® and externally mounted indication.

Option

The Unique PMO valve can be provided with or without the Alfa Laval SpiralClean.

SpiralClean

The Unique concept offers the Alfa Laval SpiralClean system to clean the upper and lower balanced plugs and leakage chamber, helping to meet the high hygienic standards of the sanitary flow industry. The system cleans more efficiently, using less cleaning fluid by ensuring that a directional flow of CIP fluid reaches all the surfaces in much less time than with conventional systems. All external CIP systems for Unique include the SpiralClean design as standard. Another benefit from the SpiralClean system is that it allows the Unique Mixproof valve to run under aseptic-like conditions. If you apply steam to the CIP pipes, this will form a steam barrier to the atmosphere.



Unique PMO UltraClean Mixproof Valve.

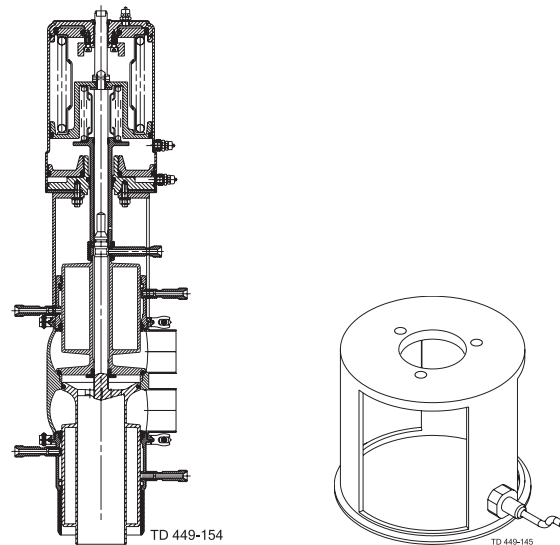

Unique PMO UltraClean Mixproof Valve with externally mounted Indication

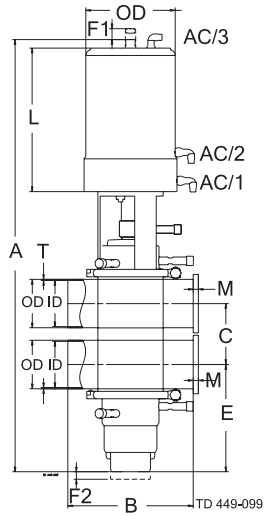

Fig. 1 Details of Unique PMO Mixproof Valve

Dimensions (Inches)

Size	2"	2½"	3"	4"
*A With SpiralClean	26.1	30.9	32.1	35.9
*A Without SpiralClean	22.6	25.7	27.0	30.78
B	8.67	8.67	11.8	11.8
**C	2.91	3.40	3.90	4.87
OD	2.00	2.50	3.00	4.00
ID	1.88	2.38	2.88	3.84
T	0.063	0.063	0.063	0.079
E With SpiralClean	6.46	7.76	8.24	9.34
E Without SpiralClean	4.49	4.96	5.48	6.54
F1	1.24	1.50	1.50	2.32
F2	0.197	0.197	0.197	0.197
øD	4.73	6.19	6.19	7.33
L Basic	9.06	9.93	9.93	11.1
M/Tri-clamp®	0.827	0.827	0.827	0.827
Weight (lb) With SpiralClean	35	59	59	84
Weight (lb) without SpiralClean	33	53	53	75

Note!

* For the A-measure if different upper/lower body sizes, please refer to CAS configurator or contact Alfa Laval.

** The measure C can always be calculated by the formula $C = \frac{1}{2}ID_{upper} + \frac{1}{2}ID_{lower} + 26 \text{ mm}$.

Ranges

Version with SpiralClean

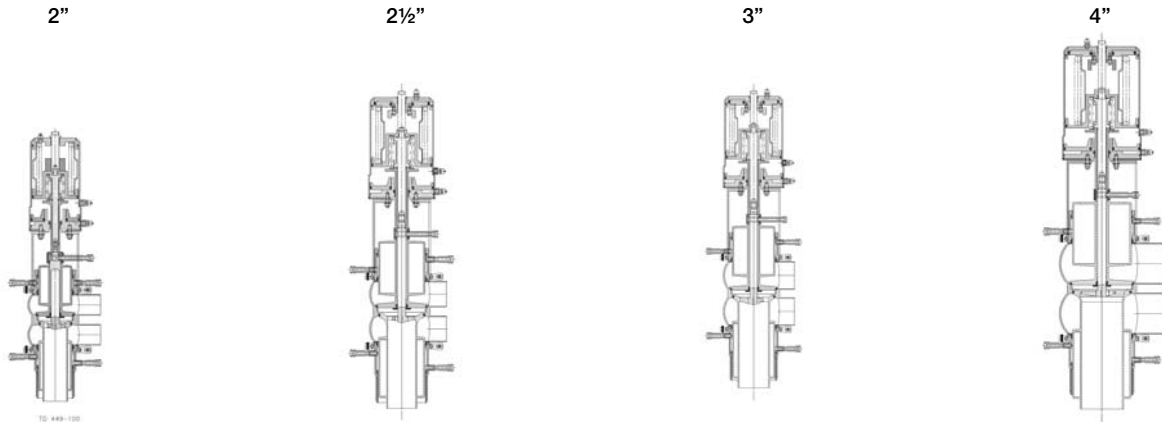

Version without SpiralClean

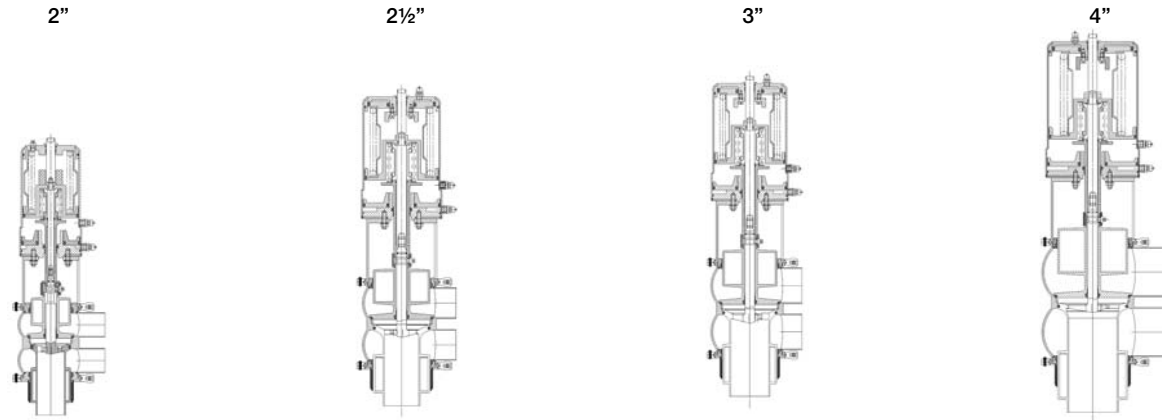

Pressure drop/capacity diagrams

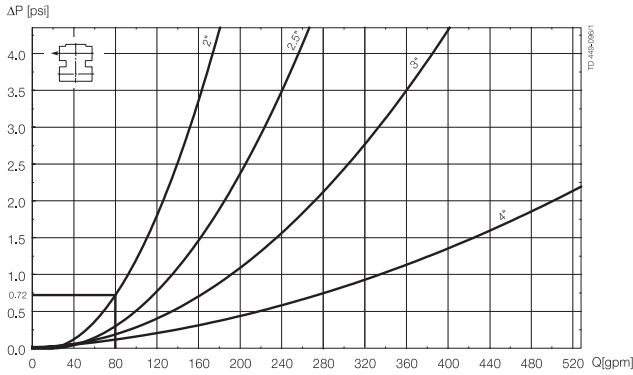

Fig. 2. Pressure drop/capacity diagram, upper bodies.

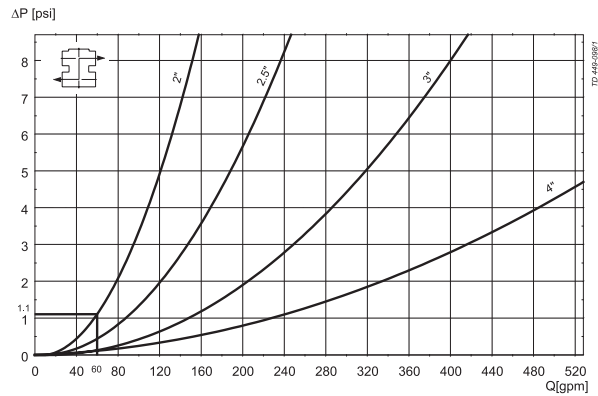

Fig. 3. Pressure drop/capacity diagram, lower body.

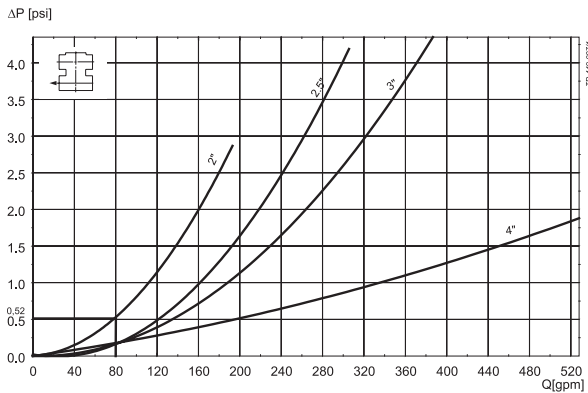

Fig. 4. Pressure drop/capacity diagram, between bodies

Note! For the diagrams the following applies:
 Medium: Water (68°F).
 Measurement: In accordance with VDI 2173.

Example to determine pressure drop:

Upper body size: 2". Capacity = 80 gpm.
 Lower body size: 3". Capacity = 80 gpm.
 Between bodies: 4". Capacity = 60 gpm.

Result:

- From fig. 3, $\Delta p = 0.72$ psi through upper body.
- From fig. 4, $\Delta p = 0.52$ psi through lower body.
- From fig. 5, $\Delta p = 1.1$ psi

Valve body combinations

