

Maintain System Pressure

CPM Constant-Pressure Modulating Valve

Application

CPMI-2, CPMI-D60 and CPMO-2 are sanitary constant-pressure valves for use in stainless steel pipe systems.

CPMI-2 and CPMI-D60 (Constant-Pressure Modulating Inlet) maintain a constant pressure in the process line at the inlet side of the valve. Typical applications of CPMI-2 and CPMI-D60 are after separators, heat exchangers etc. and as overflow valves.

CPMO-2 (Constant-Pressure Modulating Outlet) maintains a constant pressure in the process line at the outlet side of the valve. Typical applications of CPMO-2 are before filling/bottling machines etc.

Working principle

CPMI-2, CPM-I-D60 and CPMO-2 are remote-controlled by means of compressed air. The valves operate without a transmitter in the product line and require only a pressure regulating valve for the compressed air and a pressure gauge in the product line (see fig. 5).

A diaphragm/valve plug system reacts immediately to any alteration of the product pressure and changes position so that the preset pressure is maintained.

CPMI-2 and CPM-I-D60 open at increasing product pressure and vice versa. CPMO-2 closes at increasing product pressure and vice versa (see fig. 3).

Standard Design

The CPMI-2 and CPMO-2 consist of a valve body with valve seat, cover, a valve plug with a diaphragm unit and a clamp.

The diaphragm unit consists of a stainless steel disc which is divided into sectors and of flexible diaphragms which are placed on each side of the sectors.

The cover and the valve body are clamped together. The valve body and the seat are welded together.

The CPM-I-D60 consists of upper and lower valve bodies, an inlet tube, a cover, a valve plug with diaphragm unit and clamps.

The diaphragm unit consists of two flexible diaphragms supported by 12 stainless steel sectors in between them.

The cover and the valve bodies are clamped together.



CPM-2 valve.

CPM-I-D60 valve.

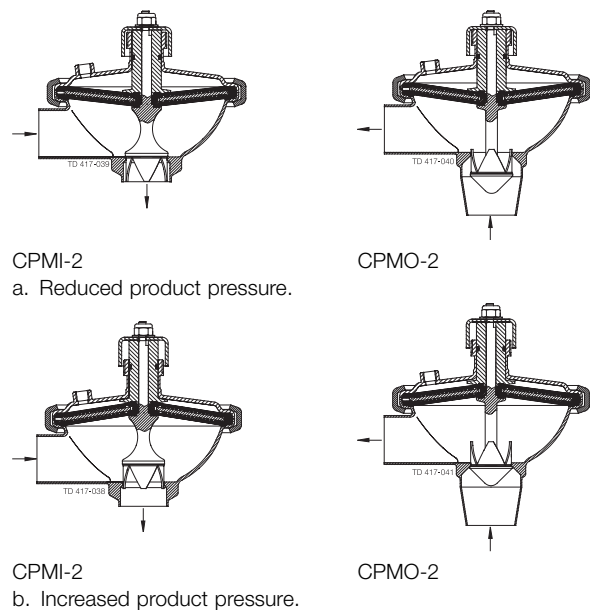

CPMI-2
a. Reduced product pressure.

CPMO-2

CPMI-2
b. Increased product pressure.

CPMO-2

Fig. 3. Principle.

Pressure drop/capacity diagrams

CPM-2, Kv 23

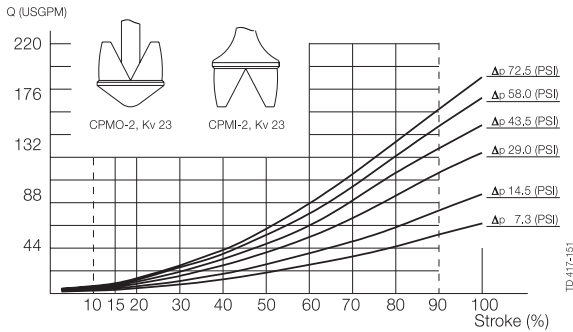

CPM-2, Kv 2/15

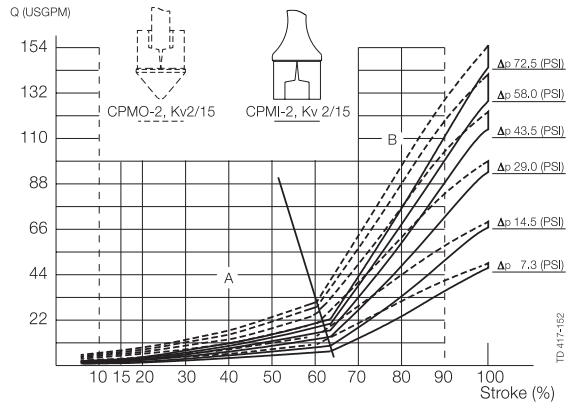

CPMI-2, Kv 7

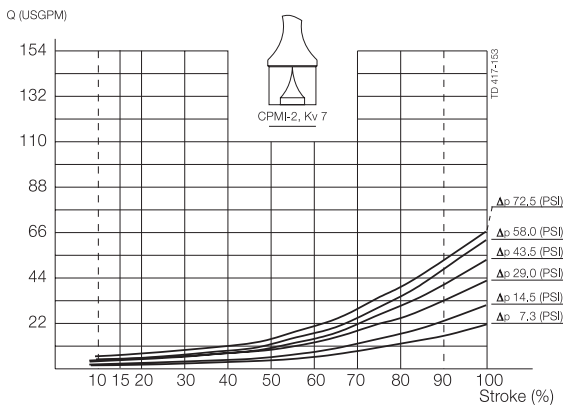

CPM-I-D, Kv 60

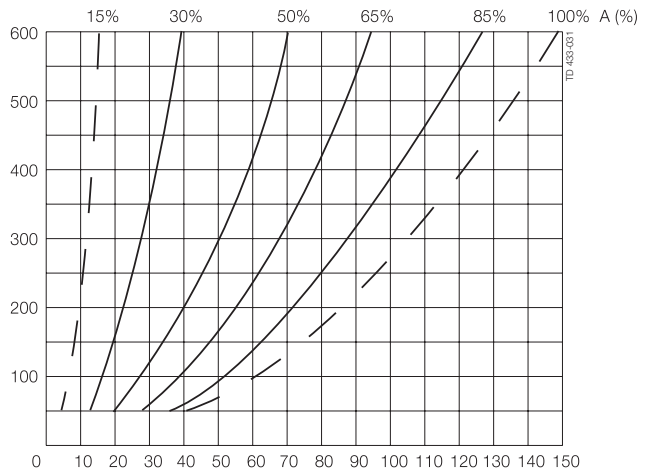

CPMO-2, Kv 9

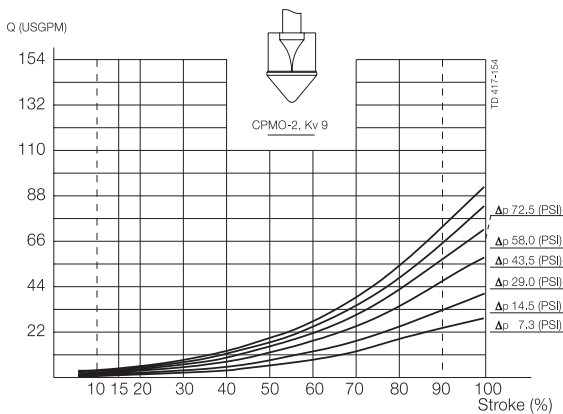

NOTE!

For all diagrams the following applies:

Medium: Water (68° F)

Measurement: In accordance with DI 2173

Example 1:

Pressure drop $\Delta p = 29$ PSI

Flow $Q = 35.2$ GPM

Select: CPM-2, Kv 23 which at working point will be 48% open.

Example 2:

CPMI-2:

Pressure drop $\Delta p = 43.5$ PSI

Flow $Q = 4.4$ GPM

Select: CPMI-2, Kv 2/15 which at working point will be approx. 35% open equal to about 50% of the regulating area.

Example of using the diagram:

1. Pressure drop $\Delta p = 36$ PSI

2. Flow = 220 GPM

The intersection is on the 50% curve.

Note!

Always try to get as near as possible to the 50% open curve. If the CPM-I-D60 is too big select from the CPMI-2 curves.

Fig. 4. Dimensions

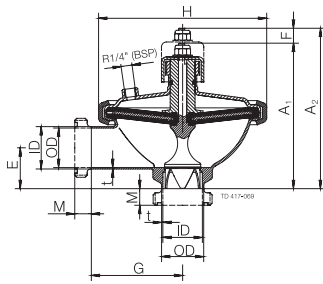

a. CPMI-2.

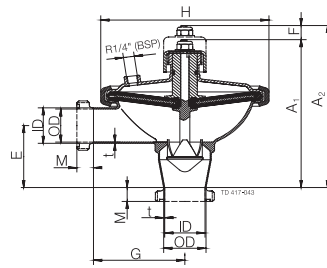

b. CPMO-2.

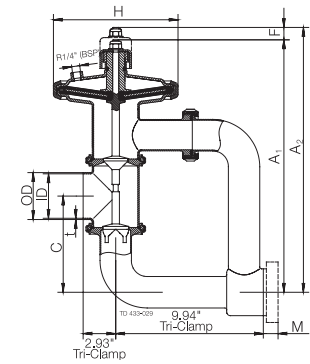

c. CPM-I-D60.

Dimensions (in.)

Size	CPMI-2			CPMO-2			CPM-I-D60
	Kv 23	Kv 7	Kv 2/15	Kv 23	Kv 9	Kv 2/15	76 mm
A1	6.89	6.89	6.89	8.13	6.89	6.89	16.27
A2	7.61	7.61	7.61	9.03	7.61	7.61	16.93
C	-	-	-	-	-	-	6.10
OD	2.00	2.00	2.00	2.00	2.00	2.00	3.00
ID	1.87	1.87	1.87	1.87	1.87	1.87	2.83
t	0.063	0.063	0.063	0.063	0.063	0.063	0.079
E	1.93	1.93	1.93	3.50	1.93	1.93	-
F	0.72	0.72	0.72	0.72	0.72	0.72	0.66
G	4.33	4.33	4.33	4.33	4.33	4.33	-
H	7.99	7.99	7.99	7.99	7.99	7.99	7.99
Tri-Clamp®	0.83	0.83	0.83	0.83	0.83	0.83	-
Seat Diameter	1.65	1.22	1.22	1.65	1.22	1.22	-
Weight (lb.)	12.10	12.10	12.10	12.10	12.10	12.10	22.00

Technical data

- Maximum product pressure145 PSI
- Minimum product pressure0 PSI
- Maximum product viscosity500 cps
- Temperature range:14° F to 203° F
- Temperature range with upper diaphragm in PTFE/EPDM14° F to 286° F (Higher on request)
- Air pressure (CPMI-2/CPMO-2)0 to 116 PSI
- Air pressure (CPM-I-D60)0 to 87 PSI

CPMI-2 and CPMO-2 are authorized to carry the 3A Symbol

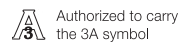

Materials

- Product wetted steel parts:Acid-resistant steel AISI 316 L
- Other steel parts:Stainless steel AISI 304
- Lower diaphragmPTFE covered EPDM rubber
- Upper diaphragmNitrile (NBR)
- Finish£ 32 RA

Air Connections

R 1/4" (BSP), internal thread.

Options**Equipment**

- A. Male parts or clamp liners in accordance with required standard.
- B. Pressure gauge 0-87 PSI, 1.5-inch
Pressure gauge 0-145 PSI, 1.5-inch
Pressure gauge 0-145 PSI, 2-inch (CPM-I-D60)
- C. Air pressure regulating valve kit, 0-116 PSI (D).
- D. Air throttling valve for adjustment of regulating speed for the CPM-2 valve (E).
- E. Booster for product pressure exceeding the available air pressure. (Product pressure = 1.8 x air pressure).
- F. 3A (Sanitary Standard) labelling on request for CPM-2 Valves.

Material grades CPM-2

- Upper diaphragm of PTFE covered EPDM and O-ring of Fluorinated rubber (FPM) covered EPDM rubber, (for temperature 203 - 284°F).
- Both diaphragms of solid PTFE and O-ring of Fluorinated rubber (FPM) (for temperatures above 284°F).

Material grades CPM-I-D60

- Upper diaphragm of PTFE covered EPDM rubber (for temperatures 194° F - 284°F)
- Valve body seal rings of Nitrile (NBR) or Fluorinated rubber (FPM).
- Guide O-ring of Fluorinated rubber (FPM), (for temperatures above 203°F)

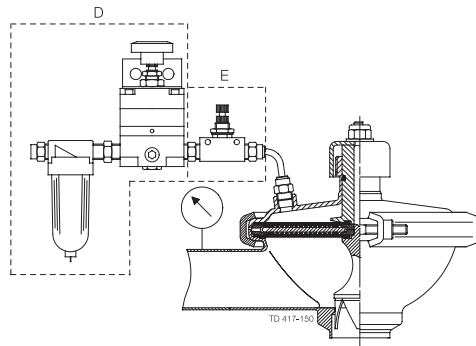

Fig. 5. CPM-I-2 with pressure regulating valve and pressure gauge.

Ordering**CPM-2**

Please state the following when ordering:

- Valve type. (CPMI-2 or CPMO-2).
- Plug size (Kv 23, Kv 7, Kv 9 or Kv 2/15).
- Diaphragm type if not standard.
- Connections if not welding ends.
- Options

CPM-I-D60

Please state the following when ordering:

- Valve type CPM-I-D60.
- Diaphragm type if not standard.
- Connections if not welding ends.
- Air pressure regulating valve if required.
- Pressure gauge size if required.
- Air pressure regulating valve if required.
- Other options.