

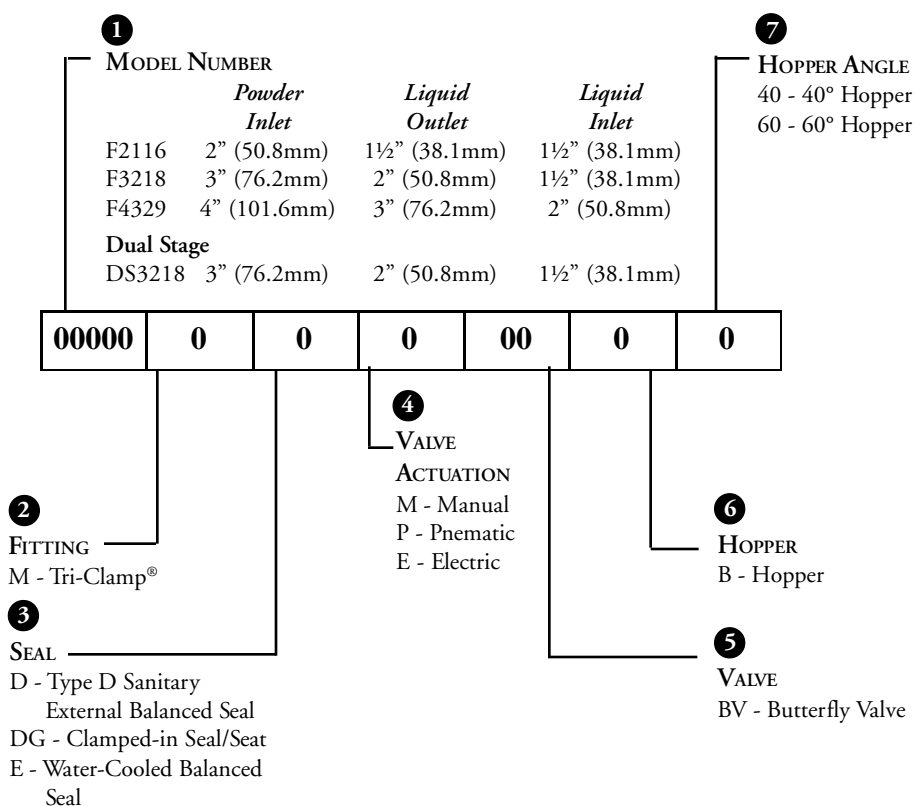

# Tri-Blender® Order Information

## Product Numbering System

Each Tri-Blender Pump is identified by a model number. An interpretation of how these numbers and letters identify pump components is explained below.



**MODEL NUMBER EXAMPLE**

1
2
3
4
5
6
7

**F2116MD - MBV - B60**



## Tri-Clover Inc.

### **Food & Dairy Division**

9201 Wilmot Road  
Kenosha, Wisconsin 53141-1413  
PHONE: 1-800-242-4000  
FAX: 414-694-7104

### **Distribution Centers**

*St. Charles, MO*  
PHONE: 1-800-238-0142  
*Union City, CA*  
PHONE: 1-800-852-3178

### **Bio-Pharm Division**

PHONE: 1-800-511-5444  
FAX: 414-694-2454

### **Tri-Clover Canada**

101 Milner Avenue  
Scarborough, Ontario M1S4S6  
PHONE: 416-297-3400  
FAX: 416-299-5095

### **Export Division**

PHONE: +1-414-697-3170  
FAX: +1-414-694-8188

### **Tri-Clover Mexico**

Recursos Petroleros No. 7  
Fracc. Ind. La Loma  
54060 Tlalhepantla, Edo. de Mexico  
PHONE: 52-5-397-0601  
FAX: 52-5-362-3246

