

Instruction Manual



Anderson Instrument Co. Inc.
156 Auriesville Road
Fultonville, NY 12072
1-800-833-0081
Fax 518-922-8997
www.andinst.com

Instrument Model Number _____

Instrument Serial Number _____



Sanitary Wiring Head RTD's & Temperature Transmitters

Form Number AIC2001
© June 1997
Revised October 2002

This manual provides the installer with instructions on assembly, installation, wiring, calibration, and troubleshooting of Anderson Temperature Transmitters.

Table of Contents

Section 1 - Introduction

1.1	Description	3
1.2	Specifications	
	RTD Elements	3
	Wiring Head	4
	Analog Transmitter Module	4 & 5
	SMART Transmitter Module	5
	Display Module	6
1.3	Ordering Matrices	
	Sanitary RTD Elements (SA)	7
	Pharmaceutical RTD Elements (SW)	8
	Wiring Head/Transmitter Modules (CT)	9

Section 2 - Assembly

2.1	Element/Wiring Head	10
2.2	Field Assembly/Replacment of Components	11

Section 3 - Installation and Wiring

Section 4 - Service 12 & 13

4.1	Calibration (Any 4-20mA Transmitter)	14
4.11	Calibration (SMART)	15
4.2	Troubleshooting	16
4.3	Replacement/Spare Parts	16

Appendices

A	Anderson 100 ohm RTD DIN Curve	17
B	Intrinsically Safe Requirements	18
C	Mini Temperature Transmitter Control Drawing	19
D	SMART Control Drawing	20
E	Warranty and Return Statement	21

Figures

1	Wiring Head Orientation	10
2	RTD "Mini" Head	11
3	Wiring Diagram : 4-20mA Transmitter	
	4-20mA "Mini" Transmitter	
	4-20mA SMART Module	12
4	Wiring Diagram : RTD (Single Element)	13
5	Wiring Diagram : RTD (Dual Element)	13

Section 1 - Introduction

1.1 Description

The Anderson Temperature Sensor you have purchased has been specifically designed for critical measurement applications in sanitary fluid processing environments. It combines all-stainless steel construction with a field replaceable element, providing a unique, "no-exposed-threads" package. The element is embedded in a metallic substrate in the probe tip which provides extremely fast response characteristics. The probe is then completely epoxy sealed for protection against moisture and vibration damage. The O-ring seal provided on the probe is unique in the industry, and eliminates the exposed threads and tall profile common to most industrial style transmitters.

Since this product line is modular in design, the specifications are divided into the following sections:

Elements (RTD's)
 Wiring Head (includes Mini)
 Analog Transmitter Module (includes (Mini)
 Digital Display Module

1.2 Specifications

1.2.1 RTD ELEMENTS

General:	Anderson SA and SW Series RTD elements are 100 ohm, 3-wire sensors which conform to DIN standards (commonly referred to as the "385 coefficient").
Type:	3 wire, 100 ohm, DIN standard, single element standard. Dual element optional with most fittings.
Coefficient:	.00385 ohms/ohm/Deg. C
Accuracy:	Conforms to ASTM E1137-B: 0.10% (0.26°C) at ice pt. 0.18% (0.66°C) at 100°C 0.21% (1.0°C) at 180°C
Probe Diameters:	1/4" Standard for direct sanitary clamp styles (1"-4") 5/32" Standard direct sanitary clamp styles (1/2" & 3/4" clamp and "mini-wells") <u>Single Element Only</u> . #41247 projectile well fitting.
Response:	2.5 to 3 seconds for 63% step change
Span:	400°F (221°C) maximum
Low End:	-50°F (-45°C) minimum
High End:	350°F (180°C) maximum
Material:	316 "L" stainless steel wettable parts
Surface Finish:	8 micro-inch R_a (SW series) 15 micro-inch R_a (SW series probes) 25 micro-inch R_a (SA series probes) 32 micro-inch R_a (thermo-well fittings)
Fitting Styles:	All standard sanitary clamp styles, including fractional clamps and mini-thermowell styles; Refer to ordering matrix for details.

1.2.2 WIRING HEAD (SAME FOR "MINI" EXCEPT WHERE NOTED IN ITALICS)

General:	The wiring head is designed to accept any type of RTD element, but offers the cleanest package when coupled with Anderson "no exposed thread" RTD's, which provide an O-ring seal against the housing. The wiring head houses the analog transmitter module and optional digital display.
Material:	304 Stainless Steel
Surface Finish:	32 micro-inch R_a max.
Dimensions:	3.15" O.D. X 2.75" L. (<i>2.00" O.D. X 1.95" L.</i>)
Penetrations:	(2) at 1/2" - 14 NPT female; (1) centered in bottom plate; (1) in side beneath cap rim.
Cable "Grip":	Optional Nema 4X "Hubbel" style connector, supplied when pre-wired cable is specified.
Ratings:	NEMA 4X

1.2.3 ANALOG TRANSMITTER MODULE (SAME FOR "MINI" EXCEPT WHERE NOTED IN ITALICS)

General:	The analog transmitter module is a one-piece sealed unit that can be factory or field installed, providing input and output terminations that are easily accessible.
Input Type:	3-wire, 100 ohm, DIN standard curve (.385 coefficient).
Output Type:	2-wire, 4-20 mA analog
Power Supply:	9 to 32 volts d.c. loop power required (14 to 37 volts d.c. with optional display).
Accuracy:	0.1% of calibrated span (when operated at calibrated voltage), linearized.
Power Supply Effect:	Less than 0.0125% of full scale output per volt.
Minimum Span:	50°F or °C
Maximum Span:	300°F, 180°C
Minimum Low End:	0°F or °C
Maximum Low End:	100°F or °C
Minimum High End:	50°F or °C
Maximum High End:	350°F, 250°C
Wiring Connections:	Screw terminals with #3 screws. <i>(removable screw terminal connectors that accept 30-14 AWG conductors)</i>
Isolation:	Non-isolated.

1.2.3 ANALOG TRANSMITTER MODULE (SAME FOR "MINI" EXCEPT WHERE NOTED IN ITALICS) CONT.

Burn-Out: Upscale (factory standard) downscale (consult factory)
Zero Adjustment: "Pot" adjustable to $\pm 25^{\circ}\text{F}$ ($\pm 15^{\circ}\text{C}$) typical

Span Adjustment: "Pot" adjustable over a $\pm 25^{\circ}\text{F}$ ($\pm 15^{\circ}\text{C}$) range minimum

Agency Approvals:
Electromagnetic Compatibility (EMC):
Mini Only: CE Compliant (Accuracy de-rated up to 0.2% in 226 - 250 MHz and 0.7% in 508 - 533MHz, 3V/M RF Field).
Std. Only: CE Compliant (Accuracy de-rated up to 4% in 200 - 300 MHz 3V/M RF Field).

Hazardous Locations: (Mini Only) Meets UL requirements for Class 1, Div. 1&2; Groups A-D for intrinsically safe apparatus when installed with barrier as required in control drawing provided in manual.

1.2.4 "SMART" TRANSMITTER MODULE

Input: 3 wire RTD, 100 ohm, DIN std. (.00385 ohms/ohm/ $^{\circ}\text{C}$).
Output: 4-20mA, linear with temperature; Digital output signal superimposed on 4-20mA signal; "HART" compliant.

Isolation: Input/Output isolated to 500V rms (707V p-p).
Accuracy: $\pm 0.1\%$ of Upper Range Limit (URL); Includes non-repeat ability, non-linearity, and hysteresis.

Stability: 0.1 $^{\circ}\text{C}$ per 6 months.
Maximum Span: 230 $^{\circ}\text{C}$
Minimum Span: 10:1 turndown (23 $^{\circ}\text{C}$)
Maximum Range: -50 to 180 $^{\circ}\text{C}$.
Power Required: 14-40 VDC external loop power (unregulated).
Power Supply Effect: Less than 0.005% of span per Volt.
Maximum Loop Resistance: (Supply Voltage - 14) x 40 = Ohms.

Agency Approvals:
Electromagnetic Compatibility (EMC):
CE Compliant (for optional LCD only, display accuracy de-rated up to 2% in 150 - 180 MHz and 230 - 350MHz, 10V/M RF Field).

Hazardous Locations: Meets UL requirements for Class 1, Div. 1&2; when installed with barrier as required in control drawing provided.

Ambient Limits: -18 to 50 $^{\circ}\text{C}$.
Ambient Effects: $\pm 0.13^{\circ}\text{C}$ per 28 $^{\circ}\text{C}$ temperature change.
Storage Temperature: -40 to 65 $^{\circ}\text{C}$
Humidity: 0 to 100% RH
Vibration Effects: Will withstand 2 g at 10-60 Hz.
Failure Mode: Field Selectable, High or Low
Warranty: Two Years.

1.2.5 DISPLAY MODULE

General:	The display module provides a local display of temperature or output value in milliamps or percent. It mounts in the cap and is powered by the loop power supply. It is designed to be easily added to any unit in the field or can be specified initially with any unit containing an analog transmitter.
Digits:	3 - 1/2 digits
Digit Size:	.5" High
Type:	LCD (Liquid Crystal)
Mounting:	Integral to cap; field replaceable/upgradeable
Units of Display:	4-20mA; 0-100%; Degrees C (0-180.0°C max); Degrees F (0-199.9°F max) factory set, or 0-300°F.
Accuracy:	±0.2% of scale
Loop Resistance:	Adds less than 250 ohms.

1.3 Ordering Matrices

1.3.1 SANITARY RTD ELEMENTS (SA)

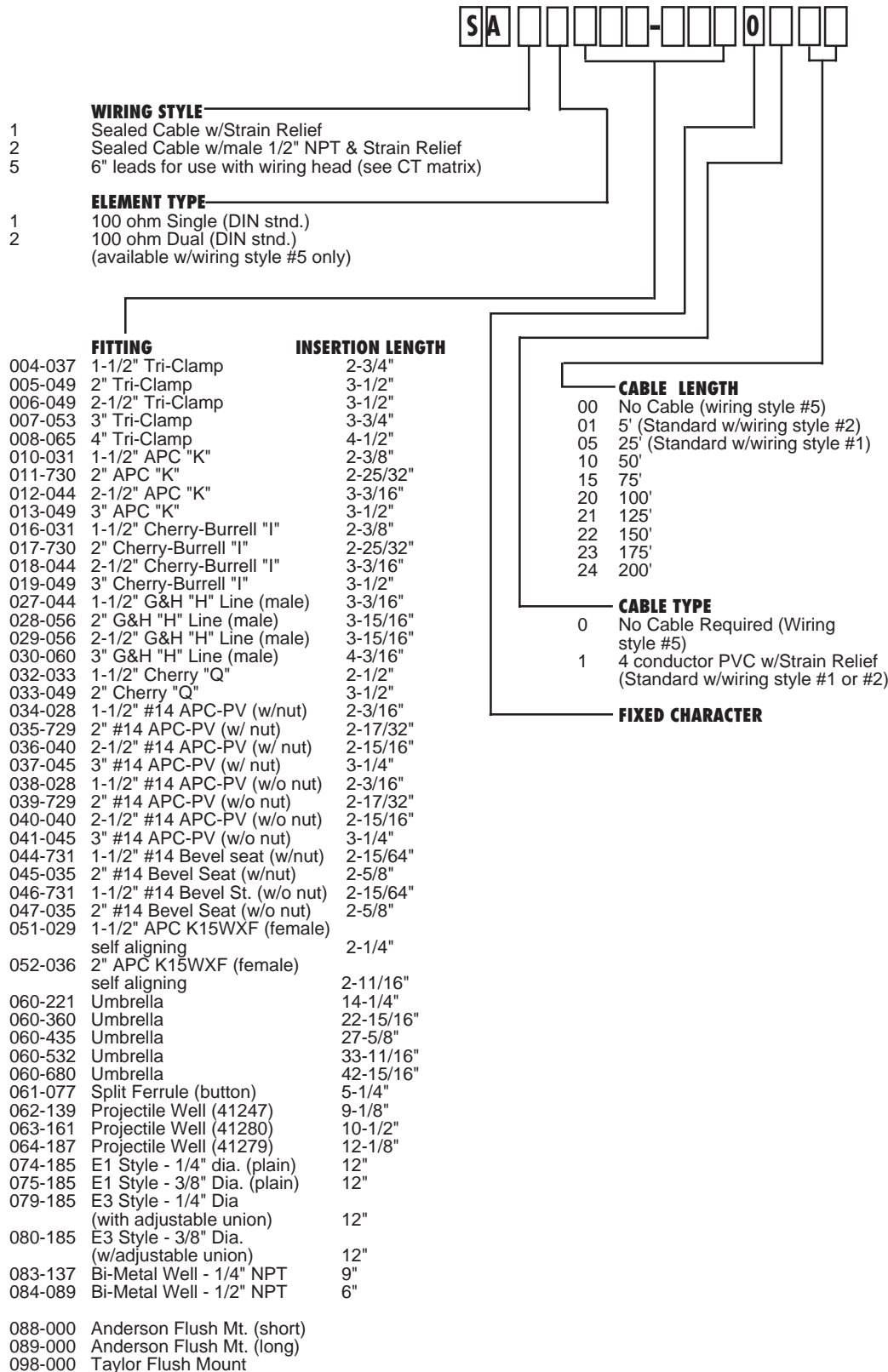

1.3.2 PHARMACEUTICAL RTD ELEMENTS (SW)



WIRING STYLE	
1	Sealed Cable w/Strain Relief
2	Sealed Cable w/male 1/2" NPT & Strain Relief
5	6" leads for use with wiring head (see CT matrix)
ELEMENT TYPE	
1	100 ohm Single (DIN std.)
2	100 ohm Dual (DIN std.) (available w/wiring style #5 only)
FITTING	
001-011	1/2" Tri-Clamp*
002-013	3/4" Tri-Clamp
002-037	3/4" Tri-Clamp
004-037	1-1/2" Tri-Clamp
005-049	2" Tri-Clamp
006-049	2-1/2" Tri-Clamp
007-053	3" Tri-Clamp
008-065	4" Tri-Clamp
010-031	1-1/2" APC "K"
011-730	2" APC "K"
012-044	2-1/2" APC "K"
013-049	3" APC "K"
016-031	1-1/2" Cherry-Burrell "I"
017-730	2" Cherry-Burrell "I"
018-044	2-1/2" Cherry-Burrell "I"
019-049	3" Cherry-Burrell "I"
027-044	1-1/2" G&H "H" Line (male)
028-056	2" G&H "H" Line (male)
029-056	2-1/2" G&H "H" Line (male)
030-060	3" G&H "H" Line (male)
032-033	1-1/2" Cherry "Q"
033-049	2" Cherry "Q"
062-139	Projectile Well (41247)
064-187	Projectile Well (41279)
083-137	Bi-Metal Well - 1/4" NPT
084-089	Bi-metal Well - 1/2" NPT
PROBE LENGTH/(STANDARD DIAMETER)	
1-1/8"	(.156"; Single Element Only)
1-1/4"	(.156" Single; .250" Dual)
2-3/4"	(.156" Single; .250" Dual)
2-3/4"	(.250" Single or Dual)
3-1/2"	(.250" Single or Dual)
3-1/2"	(.250" Single or Dual)
3-3/4"	(.250" Single or Dual)
4-1/2"	(.250" Single or Dual)
2-3/8"	(.250" Single or Dual)
2-25/32"	(.250" Single or Dual)
3-3/16"	(.250" Single or Dual)
3-1/2"	(.250" Single or Dual)
2-3/8"	(.250" Single or Dual)
2-25/32"	(.250" Single or Dual)
3-3/16"	(.250" Single or Dual)
3-1/2"	(.250" Single or Dual)
3-3/16"	(.250" Single or Dual)
3-15/16"	(.250" Single or Dual)
3-15/16"	(.250" Single or Dual)
4-3/16"	(.250" Single or Dual)
2-1/2"	(.250" Single or Dual)
3-1/2"	(.250" Single or Dual)
9-1/8"	(Tapered to Fit Well)
12-1/8"	(Tapered to Fit Well)
9"	(.250" Single or Dual)
6"	(.250" Single or Dual)
FIXED CHARACTER	
CABLE TYPE	
0	No Cable Required (Wiring style #5)
1	4 conductor PVC w/Strain Relief (Standard with wiring style #1 or #2)
3	3 conductor (red, red, white), White Teflon Jacket (FEP) (available with wiring style #1 or #2 only)
CABLE LENGTH	
00	No Cable (wiring style #5 above)
01	5' (Standard with wiring style #2)
05	25' (Standard with wiring style #1)
10	50'
15	75'
20	100'
21	125'
22	150'
23	175'
24	200'

* Recommended for "short outlet T" applications (BPE dimensions).

1.3.3 WIRING HEAD/TRANSMITTER MODULES (CT)

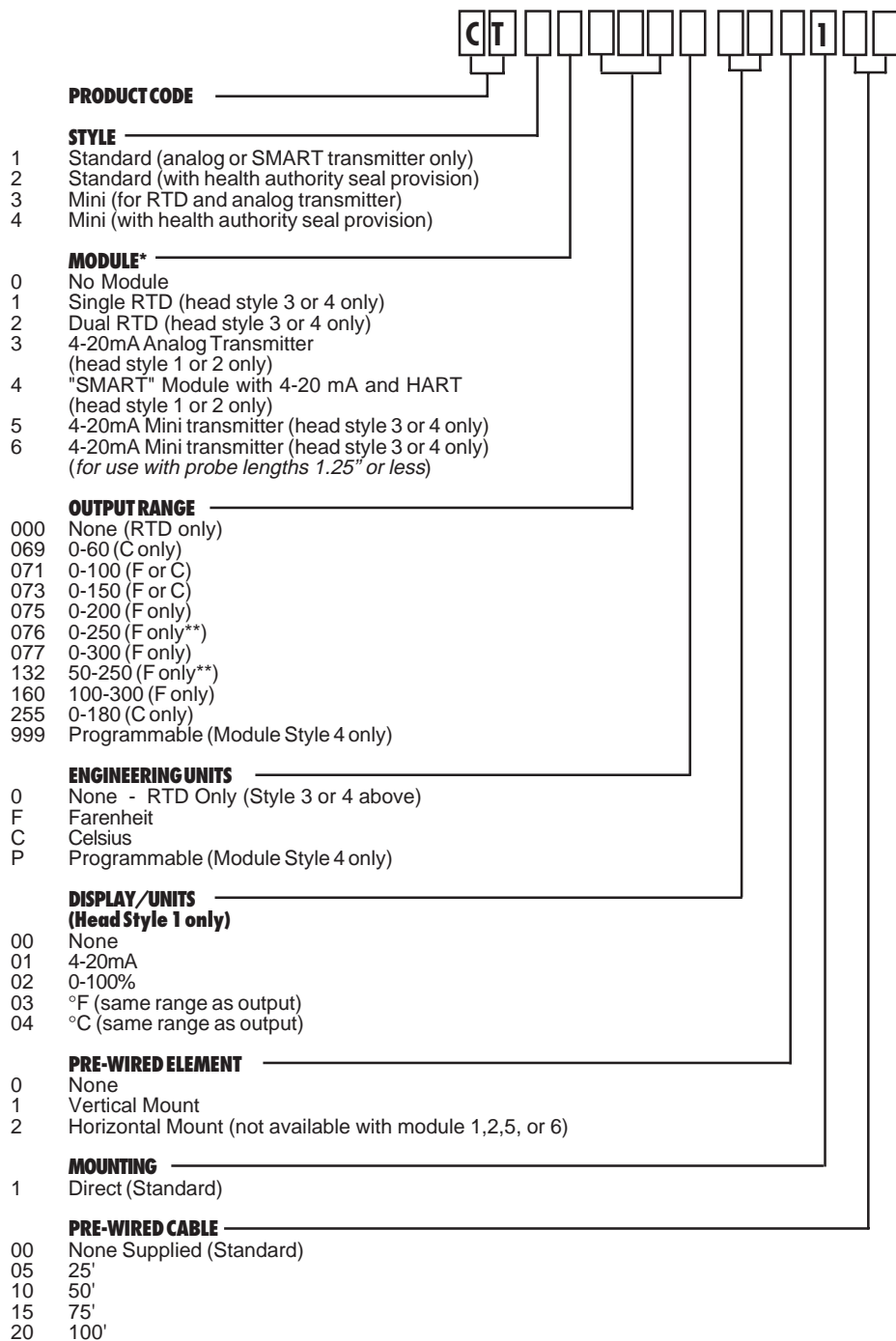

* To order only the output module, consult our Customer Service Department.

"SMART" Module Part Number: 5610100003

** This range available with display options 00, 01, 02 only.

Section 2 - Assembly

2.1 Element/Wiring Head

Anderson temperature sensors are generally ordered pre-assembled and calibrated. The RTD sensor is connected to the wiring head and pre-wired to the RTD or transmitter module. Refer to Section 3 for instructions on connecting field wiring to the unit.

If ordered as separate components, the following diagram shows the options for orientation of the wiring head.

Figure 1 - Wiring Head Orientation

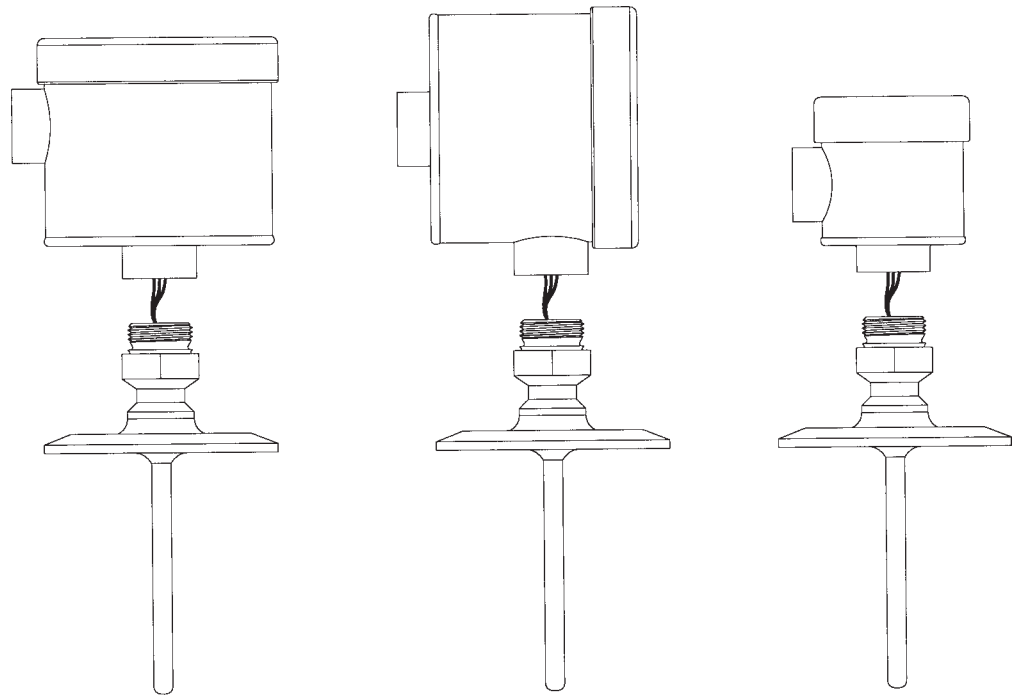

Vertical

Horizontal

Mini RTD Head
Vertical Mount Only

2.2 Field Assembly/Replacement of Components

CAUTION: When replacing any components, or upgrading any module, first interrupt power to the unit.

Transmitter Module: Regardless of orientation, the transmitter module is always mounted in the base of the wiring head, using the two screws supplied. The module should be orientated as shown in the "Wiring Diagram". Tighten the screws snugly with a medium size screwdriver. The mini transmitter module is permanently installed in the mini wiring head and is not equipped with screws.

RTD Sensors: Sealed Cable RTD's are pre-wired and ready to install. Sensors for use with wiring heads are shipped with factory supplied teflon tape on the threads. If removed, replace with a single wrap of teflon tape to lubricate the threads and prevent galling. Remove the wiring head cap and insert the RTD wires up through the center of the module (vertical mount) and through the side penetration (horizontal mount). The best orientation for an application will generally depend on whether a display will be included. If so, the wiring head should be oriented to provide the best viewing angle for the display. Hand tighten the sensor into the head and then use a wrench to apply approximately 30 ft-lbs. of torque.

For Transmitter applications, connect the three RTD wires to terminals labeled SIG, COM, and COM. The odd color (black) wire connects to SIG, and the two with the same color (white) connect one each to the COM terminals. For RTD applications, wire each lead under a separate terminal screw as shown in Figure 4 or 5.

Optional Display: If supplied, the digital display module should now be connected. Install the Red wire to terminal DISP+ and the Black wire to DISP-. With the display wired, now cut the factory installed jumper wire as shown on the wiring plate, and in the wiring diagram. If the display is being retro-fit into an existing, blind transmitter, the cap must also be replaced with the cap supplied with the display module.

The unit is now ready for connection to field wiring.

Figure 2 - RTD and Transmitter "Mini" Head

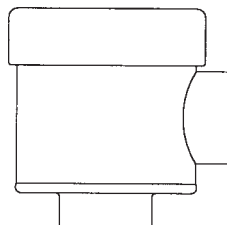

Section 3 - Installation and Wiring

Install the sensor into the process using the appropriate sanitary clamp and gasket, or by threading into a mating thermowell. Orient the conduit connection for ease of connection to field wiring before final tightening.

Field wiring should be PVC coated, shielded, 22-24 AWG cable with at least two conductors for transmitters and three for RTD's. Trim the shield back so it cannot contact the stainless steel head. (The shield wire should be connected to a single, clean ground terminal at the receiver or power supply). Strip and tin the conductors. For Transmitters, connect the positive lead from the power supply to the LOOP+ terminal and the other lead to LOOP-. The mini transmitter is provided with removable plug terminals instead of terminal blocks to facilitate wiring. The plugs must be reinstated in the transmitter after the field wires are connected to the plugs. See the wiring diagram below for details.

Figure 3 - Wiring Diagram: 4-20mA Transmitter, 4-20mA "Mini" Transmitter, and 4-20mA SMART Module

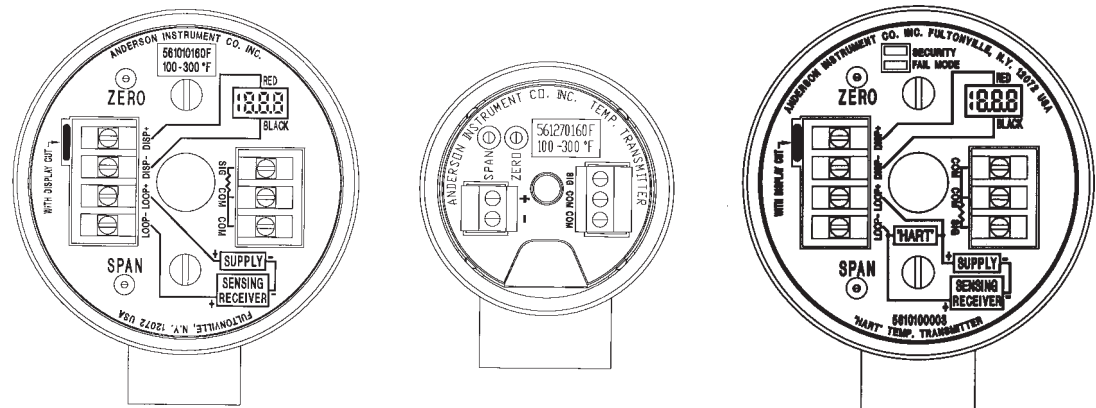

KEEP THE WATER OUT: Every precaution has been taken in designing these sensors to eliminate failures due to internal moisture. The sensors are epoxy sealed and the circuit board is completely "potted". The sensor and cap are both O-ring sealed to the housing. The only remaining pathway for moisture is via the field wiring penetration. If care is taken to insure this connection is watertight, you can expect literally years of reliable service from the sensor. Flexible or rigid conduit can be utilized to protect field wiring but it must be installed in such a manner that water vapor cannot condense inside and find it's way to the wiring head. This requires careful sealing of each and every connection and junction box along the way back to the receiver. With short, dedicated runs, this approach has proven effective. The longer the run, and the more connections, the more chance for leaks.

Another option is to terminate the conduit just short of the wiring lead penetration and utilize a water-tight (NEMA 4X) style cable grip to seal against the cable. If ordered with pre-wired cable, a cable grip is supplied, which is optimum for the 24 AWG cable supplied. If the cable is replaced, be sure to select one with a diameter of .187" to .250".

Once the sensor is properly wired, replace the display and/or cap before powering the unit.

For RTD applications, wire the two common (same color) wires to the terminals as shown.

Figure 4 - Wiring Diagram : RTD (Single Element)

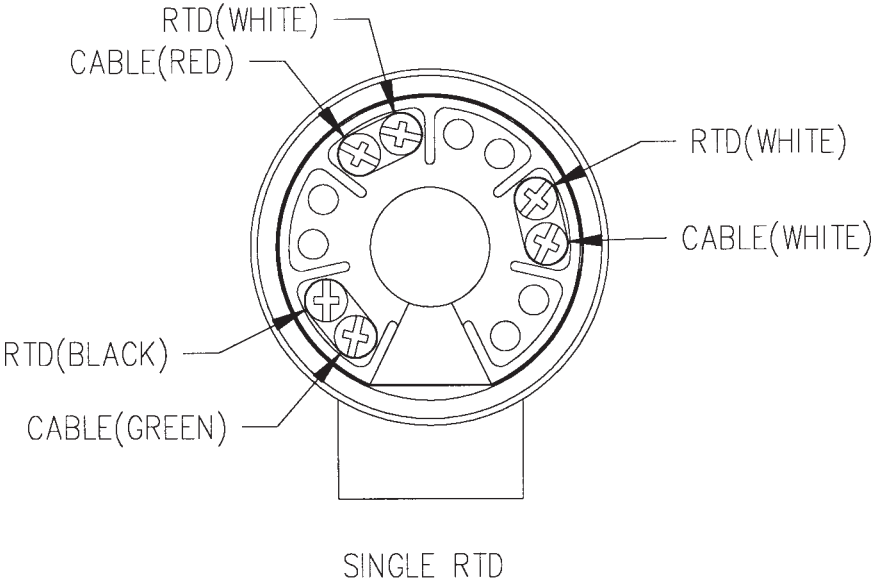
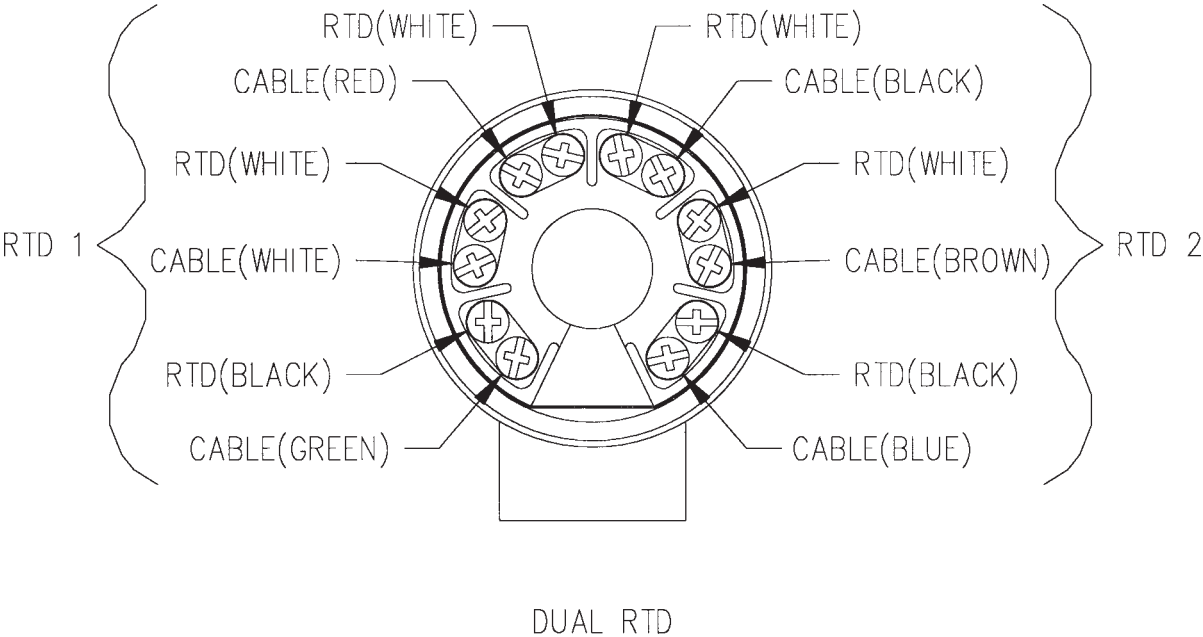

Figure 5 - Wiring Diagram : RTD (Dual Element)



Section 4 - Service

4.1 Calibration (Any 4-20mA Transmitter)

RTD sensors are not adjustable but can be checked for proper operation using the procedure in paragraph 3, section 4.2.

Anderson transmitters may be calibrated by making adjustments to the electronic circuitry via a ZERO and a SPAN screw or "pot" contained within the sensor housing. If the transmitter is to be calibrated, the following equipment will be required:

Well Agitated and Controlled Temperature Bath
Accurate Reference (lab thermometer)
12-40 VDC Power Supply
DC Milliammeter (accurate to .01 mA)
Jumper Leads
Jeweler's Screwdriver
Calculator

The output of a properly calibrated transmitter may be calculated by using the following formula:

$$\text{mA output} = 16 \times \frac{(\text{Known Value} - \text{Low End of Range})}{\text{Transmitter Span}} + 4$$

The calibration procedure for Anderson Temperature and Transmitters is as follows:

1. Remove the conduit cap from the transmitter housing.
2. Wire up the transmitter as shown in the wiring diagram. Monitor the loop current with a milliammeter.
3. Expose the sensor to a temperature near the low end of the range and allow the reading to stabilize.
4. Calculate the proper reading using the formula above.
5. Adjust the zero pot (labeled ZERO) to cause the meter to read the proper reading.
6. Expose the sensor to a temperature near the high end of the range and allow the reading to stabilize.
7. Again, calculate the correct reading.
8. Adjust the span pot (labeled SPAN) to cause the meter to read the calculated reading.
9. Repeat steps 3. through 8. until no further adjustment is necessary.

NOTE: For temperature transmitters with offset values less than zero, care must be taken not to lose the (-) sign while performing the calculation of the proper reading.

4.11 Calibration (SMART)

The Smart Module may be calibrated using the technique outlined in this manual for the analog transmitter module. If utilizing a HART Communicator (HHT), follow the procedure below:

- 1.) Power the transmitter and immerse the probe in an ice bath for several minutes:
(Note: Consult our Technical Service Department if °C is NOT within the desired calibration range for the unit being calibrated). The signal loop must have at least 250 ohms resistance for the HHT function.
- 2.) Connect the "HART" HHT across the transmitter terminals, or the resistor in the loop.
- 3.) Press the I/O button on the HHT to turn it on, wait until communications are established and the Process Value (PV) is displayed.
- 4.) If the Process Value is not within specification after stabilization:
 - a.) Move the right arrow to "Detailed Setup" and make the following selections:
 - "1" (Sensors)
 - "2" (Temp Sensor)
 - "3" (Sensor Trim)
 - "1" (Zero Trim)
 - "OK", "OK", "OK", "OK"
 - "HOME"
 - b.) Verify Process Value is now within specification
- 5.) Immerse the probe in a "hot" bath that is well agitated, within 10% of the upper range limit of the transmitter.
- 6.) If the Process Value is not within specification after stabilization:
 - a.) Move the right arrow to "Detailed Setup" and make the following selections:
 - "1" (Sensors)
 - "2" (Temp Sensor)
 - "3" (Sensor Trim)
 - "2" (Upper Trim)
 - "OK", "OK", "OK", "OK"
 - "HOME"
 - b.) Verify the Process Value is now within specification.

4.2 Troubleshooting

In the event a problem arises with the temperature measurement being monitored by the sensor, quickly check all wiring connections between the sensor and receiver. Be sure all connections are still proper and tight.

For transmitters, if the receiver indicates a temperature that is in error when compared to other instruments in the process, the milliamp signal can be checked without removing the transmitter from the process. Simply wire a milliammeter in series with the transmitter output and calculate the proper signal for the known temperature, using the formula in the calibration section. If the output agrees with the calculated value, the receiving instrument requires recalibration. If it is out of tolerance (>.04mA error), the transmitter must be removed from the process and calibrated.

If the receiver indicates a failure condition such as an out-of-range value, and the wiring checks out, the RTD signal wires can be disconnected from the transmitter module and checked for the proper resistance. Use the table provided to determine the proper resistance for the temperature being monitored, then check for that resistance between the black lead and each of the white leads. The resistance should read approximately the same as the value from the chart (Appendix A) that corresponds with the test temperature. Also check for an "open" or "short" circuit by measuring the resistance between each lead and the stainless steel probe. An infinite resistance indicates an "open" circuit and zero resistance indicates a "short" circuit. In the case of a short circuit, the element needs to be replaced.

If RTD/Transmitters with insertion lengths of 1-1/4" or less output low, thermal insulation should be packed around the RTD and its fitting to minimize heat loss to ambient.

If the RTD checks out and the output is still out-of-range, the transmitter module is suspect and should be replaced. Replacement of the mini transmitter module requires replacement of the wiring head since the transmitter and head are integral.

4.3 Replacement / Spare Parts

4.3.1 RTDELEMENTS

Replacement or spare elements can be ordered using the ordering matrix in this manual or by contacting our Customer Service Department with the serial number or model number of the original element.

4.3.2 TRANSMITTER MODULES

4-20mA modules can be ordered by the model number on the label, or simply by specifying the range and units required (e.g. 0-200°F). The 4-20mA mini transmitters can only be ordered by the CT number identified on the side of the mini wiring head.

4.3.3 DIGITAL DISPLAY MODULES

As with the transmitter modules, order by range and units.

4.3.4 REPLACEMENT WIRING HEAD CAP

Standard Cap	#56093-00001
Standard Cap with Health Authority Seal Option	#56093-00003
Standard Cap, for use with Digital Display	#44854-A0002
Mini Cap	#45009-A0001
Mini Cap with Health Authority Seal Option	#45009-B0001

Appendix A - Anderson 100 ohm RTD DIN Curve

0.00385 ohms/ ohm / °C

<u>Degrees Fahrenheit</u>	<u>Degrees Celsius</u>	<u>Ohms</u>
0	-17.78	93.04
5	-15.00	94.12
10	-12.22	95.21
15	-9.44	96.31
20	-6.67	97.39
25	-3.89	98.48
30	-1.11	99.57
32	0.00	100.00
35	1.67	100.65
40	4.44	101.73
45	7.22	102.82
50	10.00	103.90
55	12.78	104.98
60	15.56	106.07
65	18.33	107.15
70	21.11	108.22
75	23.89	109.31
80	26.67	110.38
85	29.44	111.45
90	32.22	112.53
95	35.00	113.61
100	37.78	114.68
105	40.56	115.76
110	43.33	116.83
115	46.11	117.90
120	48.89	118.97
125	51.67	120.04
130	54.44	121.11
135	57.22	122.17
140	60.00	123.24
145	62.78	124.31
150	65.56	125.37
155	68.33	126.44
160	71.11	127.50
165	73.89	128.56
170	76.67	129.62
175	79.44	130.68
180	82.22	131.74
185	85.00	132.80
190	87.78	133.86
195	90.56	134.91
200	93.33	135.97
212	100.00	138.50
225	107.22	141.24
250	121.11	146.48
275	135.00	151.70
300	148.89	156.90

Appendix B - Intrinsically Safe Requirements for 4-20mA Mini Transmitter

The following drawing illustrates additional requirements which must be met in order to properly wire a 4-20mA mini transmitter to be recognized as Intrinsically Safe. Specifications which must be met when choosing a barrier strip have been provided.

NOTE: Anderson does not offer barrier strips for sale at this time - please see your local electrical component supplier.

CAUTION:

ALL documented requirements **MUST** be met. A 4-20mA mini transmitter wired without a barrier strip will not meet the guidelines for Intrinsically Safe applications.

Appendix C - Mini Temperature Transmitter Control Drawing

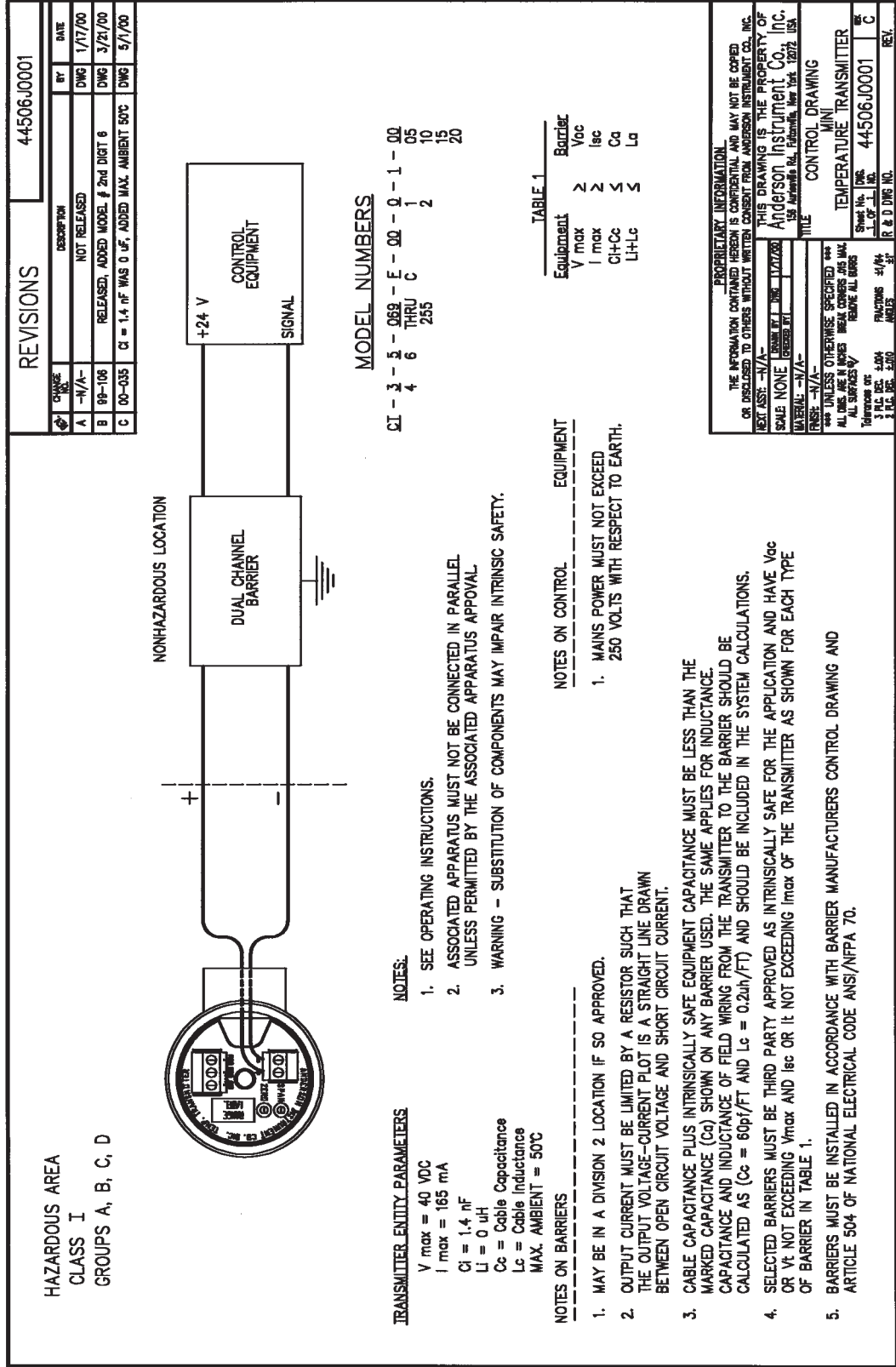

Appendix D - SMART Control Drawing

HAZARDOUS AREA
CLASS I
GROUPS A, B, C, D

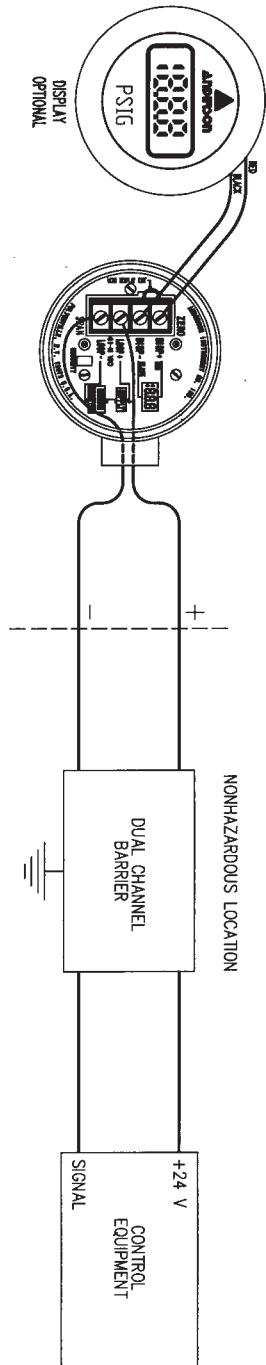

TRANSMITTER ENTRY PARAMETERS

V max = 40 VDC
I max = 165 mA
P max = 1 W
Ct = 0.01 uF
Li = 0 uh

NOTES:

1. SEE OPERATING INSTRUCTIONS.
2. ASSOCIATED APPARATUS MUST NOT BE CONNECTED IN PARALLEL UNLESS PERMITTED BY THE ASSOCIATED APPARATUS APPROVAL.
3. WARNING - SUBSTITUTION OF COMPONENTS MAY IMPAIR INTRINSIC SAFETY.

NOTES ON BARRIERS

1. MAY BE IN A DIVISION 2 LOCATION IF SO APPROVED.
2. OUTPUT CURRENT MUST BE LIMITED BY A RESISTOR SUCH THAT THE OUTPUT VOLTAGE-CURRENT PLOT IS A STRAIGHT LINE DRAWN BETWEEN OPEN CIRCUIT VOLTAGE AND SHORT CIRCUIT CURRENT.
3. CABLE CAPACITANCE PLUS INTRINSICALLY SAFE EQUIPMENT CAPACITANCE MUST BE LESS THAN THE MARKED CAPACITANCE (Cc) SHOWN ON ANY BARRIER USED. THE SAME APPLIES FOR INDUCTANCE. CAPACITANCE AND INDUCTANCE OF FIELD WIRING FROM THE TRANSMITTER TO THE BARRIER SHOULD BE CALCULATED AS (Cc = 60pf/FT AND Lc = 0.2uh/FT) AND SHOULD BE INCLUDED IN THE SYSTEM CALCULATIONS.
4. SELECTED BARRIERS MUST BE THIRD PARTY APPROVED AS INTRINSICALLY SAFE FOR THE APPLICATION AND HAVE Voc OR Vt NOT EXCEEDING Vmax AND Isc OR It NOT EXCEEDING Imax AND THE Pmax OF THE BARRIER MUST BE LESS THAN OR EQUAL TO THE Pmax OF THE TRANSMITTER AS SHOWN FOR EACH TYPE OF BARRIER IN TABLE 1.
5. BARRIERS MUST BE INSTALLED IN ACCORDANCE WITH BARRIER MANUFACTURERS CONTROL DRAWING AND ARTICLE 504 OF NATIONAL ELECTRICAL CODE ANSI/NFPA 70.

NOTES ON CONTROL EQUIPMENT

1. MAINS POWER MUST NOT EXCEED 250 VOLTS WITH RESPECT TO EARTH.

MODEL NUMBERS

I - P - P - 0 - 1 - 1 - 002 - 1 - 1 - 0 - 000
THRU THRU THRU THRU THRU THRU THRU THRU
3 2 6 123 2 A A 999
THRU B
0 R
0 Q

TABLE 1

Equipment	Barrier
V max	>
Voc	>
I max	>
Isc	>
P max	>
P max	>
Ct+Cc	>
Lt+Lc	>
Ld	>

IF Pmax OF BARRIER IS NOT KNOWN IT MAY BE CALCULATED USING THE FORMULA Voc X Isc = P1

REVISIONS		44506C0001	
CHANGE NO.	DESCRIPTION	BY	DATE
A	95-022 RELEASED	DWG	9/30/96
B	00-017 ADDED TO MODEL # FOR HT DR MT & RMT MT	LSB	2/25/00

<p>PROPRIETARY INFORMATION</p> <p>THE INFORMATION CONTAINED HEREIN IS CONFIDENTIAL AND MAY NOT BE COPIED OR DISCLOSED TO OTHERS WITHOUT WRITTEN CONSENT FROM ANDERSON INSTRUMENT CO., INC.</p>			
<p>REVISIONS: -N/A-</p> <p>SCALE: NONE</p> <p>DATE: 5/22/95</p>	<p>DESIGNER: []</p> <p>DRAWN BY: []</p> <p>CHECKED BY: []</p>	<p>TITLE: CONTROL DRAWING</p> <p>SMART PRESSURE TRANSMITTER</p>	<p>44506C0001</p> <p>REV. B</p>
<p>Anderson Instrument Co., Inc.</p> <p>1500 Anderson Ave., Anderson, IN 46012 USA</p>			

Appendix E - Warranty and Return Statement

These products are sold by the Anderson Instrument Company (Anderson) under the warranties set forth in the following paragraphs. Such warranties are extended only with respect to a purchase of these products, as new merchandise, directly from Anderson or from an Anderson distributor, representative or reseller, and are extended only to the first buyer thereof who purchases them other than for the purpose of resale.

Warranty

These products are warranted to be free from functional defects in materials and workmanship at the time the products leave the Anderson factory and to conform at that time to the specifications set forth in the relevant Anderson instruction manual or manuals, sheet or sheets, for such products for a period of one year.

THERE ARE NO EXPRESSED OR IMPLIED WARRANTIES WHICH EXTEND BEYOND THE WARRANTIES HEREIN AND ABOVE SET FORTH. ANDERSON MAKES NO WARRANTY OF MERCHANTABILITY OR FITNESS FOR A PARTICULAR PURPOSE WITH RESPECT TO THE PRODUCTS.

Limitations

Anderson shall not be liable for any incidental damages, consequential damages, special damages, or any other damages, costs or expenses with the exception of the cost or expense of repair or replacement as described above.

Products must be installed and maintained in accordance with Anderson instructions. Users are responsible for the suitability of the products to their application. There is no warranty against damage resulting from corrosion, misapplication, improper specifications or other operating conditions beyond our control. Claims against carriers for damage in transit must be filed by the buyer.

This warranty is void if the purchaser uses non-factory approved replacement parts and supplies, or if the purchaser attempts to repair the product themselves, or through a third party, without Anderson authorization.

Returns

Anderson's sole and exclusive obligation and buyer's sole and exclusive remedy under the above warranty is limited to repairing or replacing (at Anderson's option), free of charge, the products which are reported in writing to Anderson at its main office indicated below.

Anderson is to be advised of return requests during normal business hours, and such returns are to include a statement of the observed deficiency. The buyer shall pre-pay shipping charges for products returned, and Anderson, or its representative, shall pay for the return of the products to the buyer.

Approved returns should be sent to:

ANDERSON INSTRUMENT COMPANY INC.
156 AURIESVILLE ROAD
FULTONVILLE, NY 12072 USA

ATTN: REPAIR DEPARTMENT



ANDERSON INSTRUMENT CO. • 156 AURIESVILLE RD. • FULTONVILLE, NY 12072 USA • 1-800-833-0081 • FAX 518-922-8997
MAIDA INTERNATIONAL (LATIN AMERICA & ASIA) CALL 516-676-3079 • FAX 516-676-3199

www.andinst.com